

SERVICE MANUAL

MODEL: MB-4Se (V3)

CONTENTS

Replacing the Spool Stand.....	4
Replacing the Thread tension panel.....	4
Replacing the Head set right cover (unit)	5
To Replace Right Cover and Left Cover.....	6
Replacing the Base Cover and Bed Cover.....	7
Replacing the Thread Catcher Panel	8
Checking the Thread Paths (1).....	9
Checking the Thread Paths (2).....	10
Replacing the Needle / Needle and Thread Reference Table	11
Adjusting the Bobbin Thread Tension.....	12
Checking the Lowest Position of the Needle.....	13
Replacing the Needle Bar Rest	14
Replacing the Take-up Lever Cam Roller.....	15
Adjusting the Take up Lever Timing.....	16
Replacing the Presser Foot Cam	17 to 19
Replacing and Adjusting the Presser Foot (1).....	20
Replacing and Adjusting the Presser Foot (2).....	21
Replacing the Presser Foot Return Spring and Washer	22 to 24
Replacing the Thread Catcher.....	25
Replacing the Thread Catcher Hook	26

CONTENTS

Replacing the Jump Solenoid.....	27
Adjusting a Play in the Moving Head.....	28
Replacing the Moving Head (1).....	29
Replacing the Moving Head (2).....	30
Adjusting the Needle Drop Position (Back or Forth)	31
Adjusting the Needle Height.....	32
Replacing the Needle Bar, Needle Spring and Cushion.....	33
Replacing the Rotation Stopper Plate	34
Replacing the Thread Take-up Lever	35
Adjusting the Check Spring Tension.....	36
Adjusting the Check Spring Stroke	37
Adjusting the Thread Catcher Holder	38
Replacing the Thread Catcher Loop Tape.....	39
Replacing the Lateral Moving Unit.....	40
Adjust the Hook Timing.....	41
Adjusting the Position of the Hook Stopper	42
Replacing the Thread Cutter Driving Roller.....	43
Replacing the Dynamic Cutter Blade.....	44
Replacing the Static Cutter Blade.....	45
Adjusting the Static Cutter Blade.....	46

CONTENTS

Adjusting the Dynamic Cutter Blade.....	47
Adjusting the Bobbin Thread Holder.....	48
Adjusting the Thread Keeper.....	49
Adjusting the X-carriage Belt Tension.....	50
Replacing the X-carriage Belt.....	51
Adjusting the Y-carriage Belt Tension.....	52
Replacing the Y-carriage Belt.....	53
Adjusting the Timing Belt Tension.....	54
Replacing the Timing Belt.....	55
Adjusting the Motor Belt Tension.....	56
Replacing the Motor Belt.....	57
Replacing the DC Motor.....	58
To Reset Motor Drive Time.....	59
Adjusting the Needle Upper Shaft Timing.....	60
Adjusting the Moving Head Stop Position.....	61
Adjusting the Needle Stop Position.....	62
Adjusting the Carriage Home Position.....	63
Securing the Cables in the Moving Head (Upper Part).....	64
Upgrading Model 770 Series.....	65 to 69
PARTS LIST.....	70 to 113

Replacing the Spool Stand

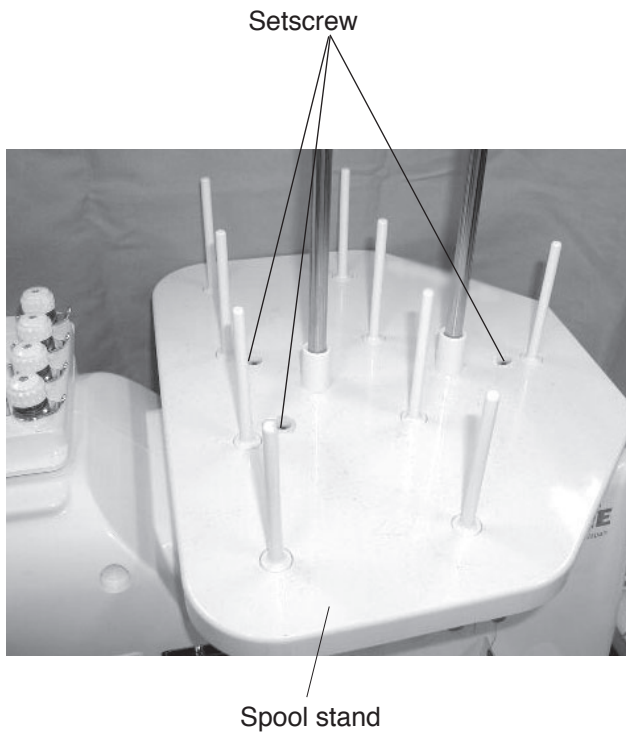

To remove:

1. Remove the setscrews(3 pcs.) and spool stand.

To attach:

2. Attach the spool stand and tighten the setscrews (3 pcs.).

Replacing the Thread tension panel

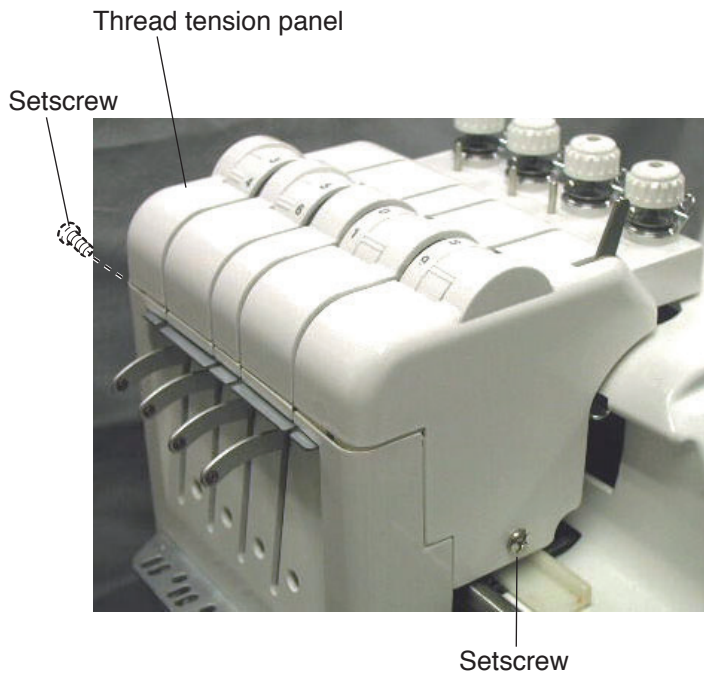

To remove:

1. Remove the setscrews (2pcs.) and thread tension panel.

To attach:

2. Attach the thread tension panel and tighten the setscrews(2 pcs.).

Replacing the Head set right cover (unit)

Cap, Setscrew A Head set right cover (unit) RCS knob



To remove:

1. Turn the RCS knob counterclockwise to remove it.
2. Remove caps, and setscrews A (2 pcs.). Remove the head set right cover (unit).
3. Disconnect the Printed circuit board L2 connector and printed circuit board K connector.

To attach:

4. Connect the Printed circuit board L2 connector and Printed circuit board K connector.
5. Attach the head set right cover (unit) with the setscrews A (2pcs.). Attach the caps (2pcs.).
6. Turn the RCS knob clockwise to attach the RCS knob.

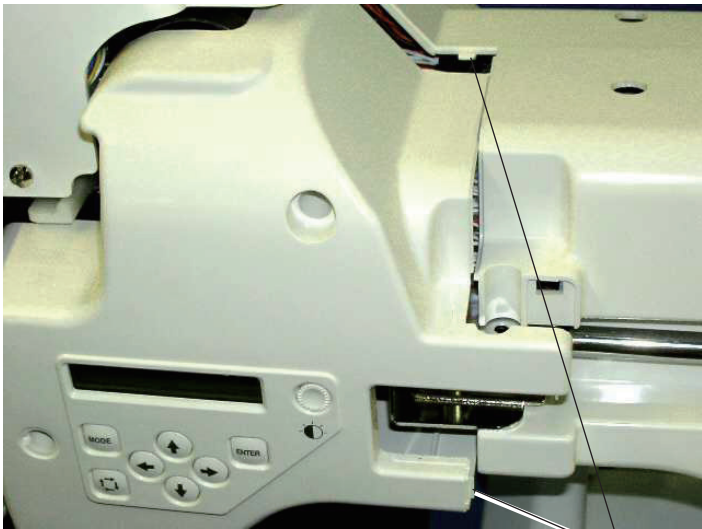

Printed circuit board L2 connector Hook
Printed circuit board K connector

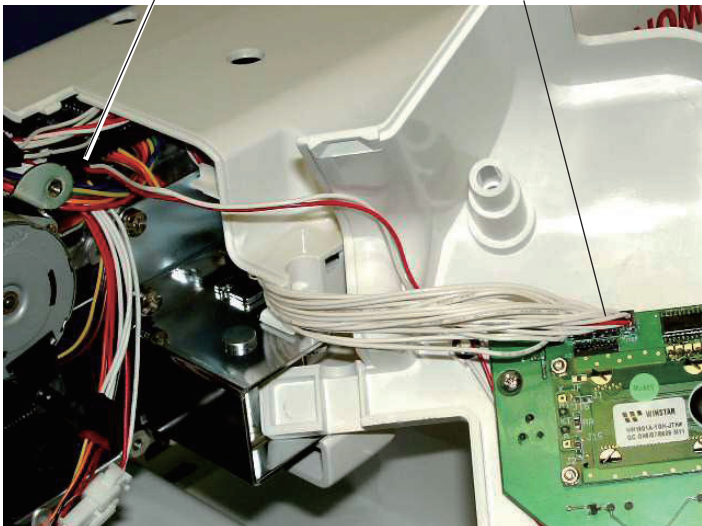

To Replace Right Cover and Left Cover

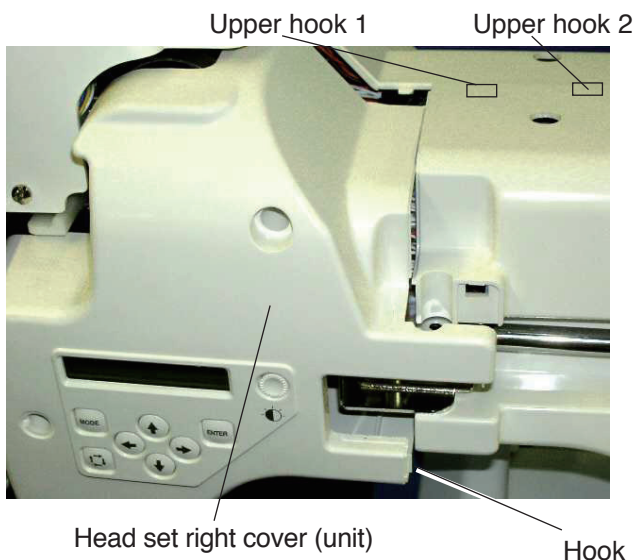

Right Cover

To remove:

1. Remove the LED lamp connector (see page 5).
Unhook the right cover from the hook.
 - To remove the right cover, Unhook the cover from upper hook 1, upper hook 2 and the hook on handwheel side.
2. Remove caps (3 pcs.) and setscrews A (3 pcs.).
Remove the right cover.

To attach:

3. Attach the right cover with setscrews A and caps.
4. Attach the head set right cover (unit).
 - Do not bind cords when attaching the right cover.

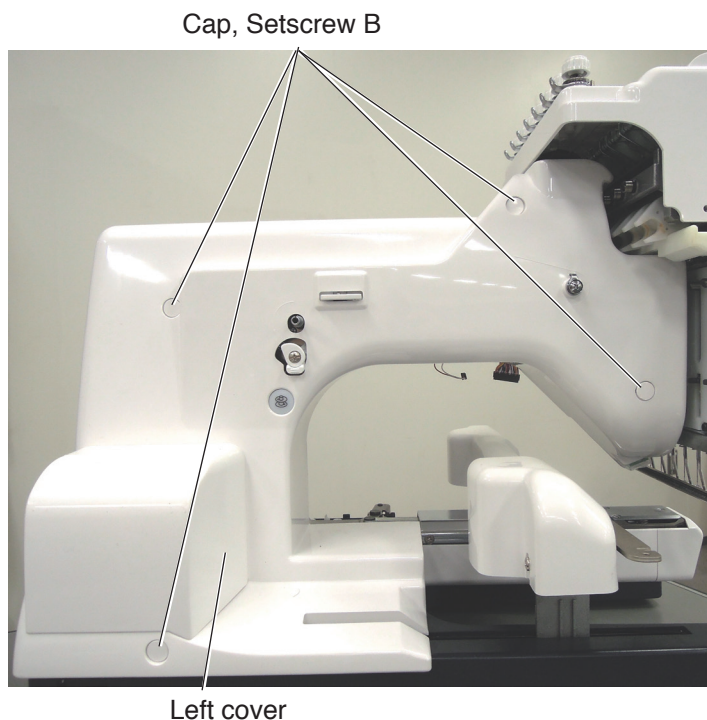
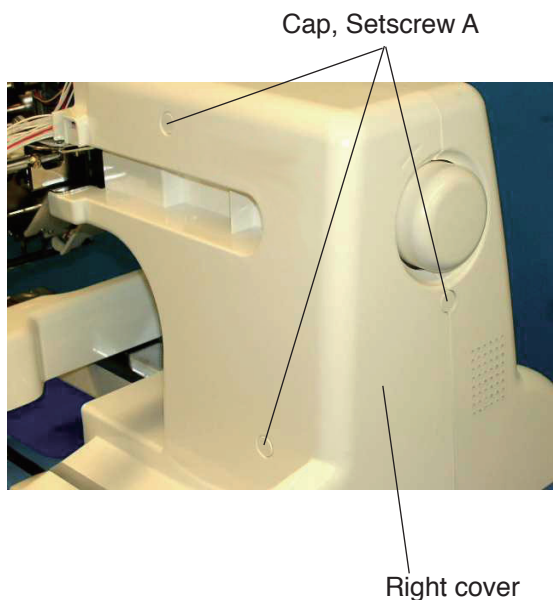

Left Cover

To remove:

1. Remove the caps (4 pcs.) and setscrews B(4 pcs.).
Remove the left cover.

To attach:

2. Attach the left cover with setscrews B (4 pcs.) and caps (4 pcs.).

Replacing the Base Cover and Bed Cover

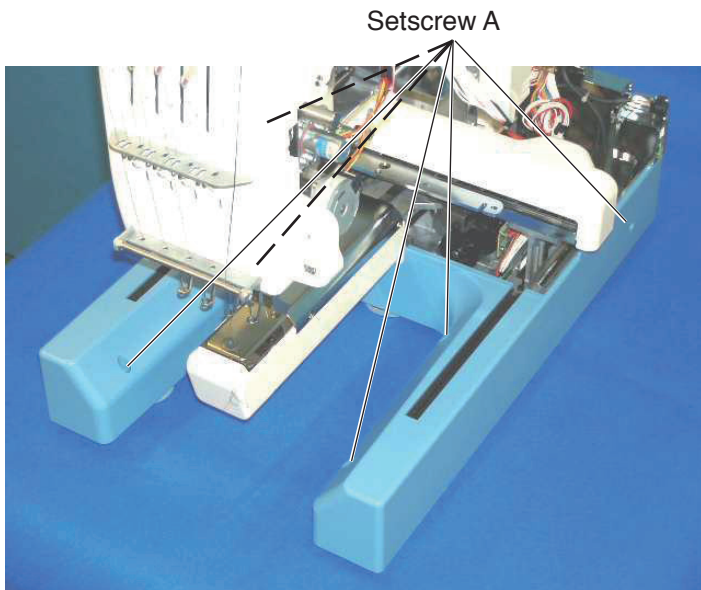

Base Cover

To remove:

1. Remove the setscrews A (6 pcs.).
2. Lift the back of the machine and remove the base cover from the base cover.

To attach:

3. Attach the machine into the base cover.
4. Tighten the setscrews A (6 pcs.) securely.

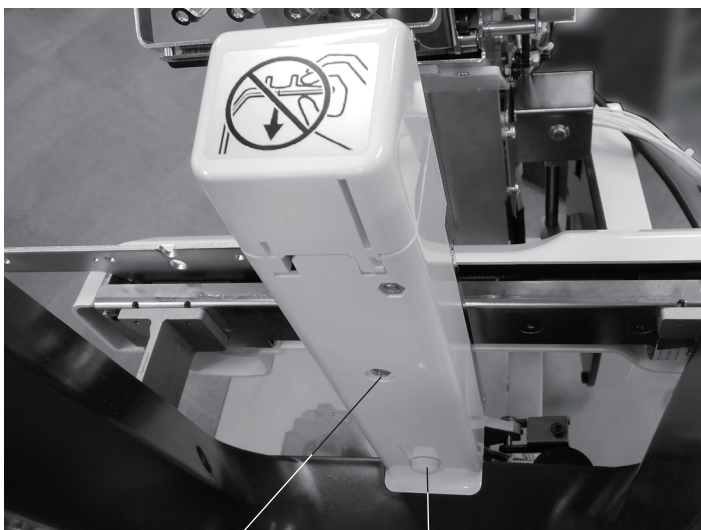
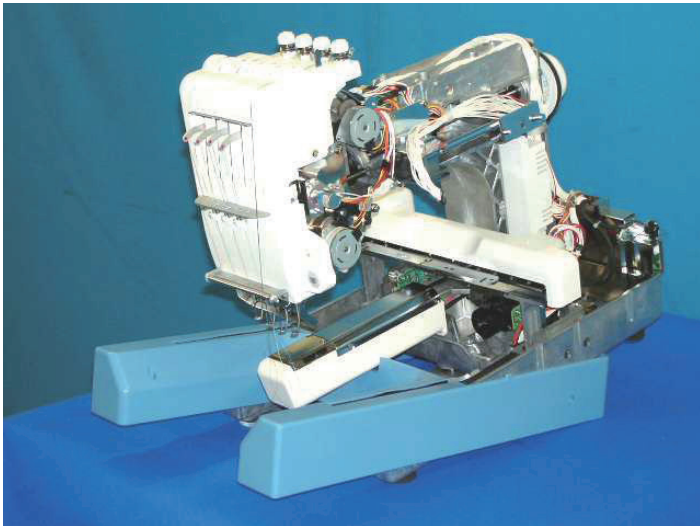

Bed Cover

To remove:

1. Remove the setscrew B and setscrew C. Remove the bed cover.

To attach:

2. Attach the bed cover with the setscrew B and setscrew C.

Replacing the Thread Catcher Panel

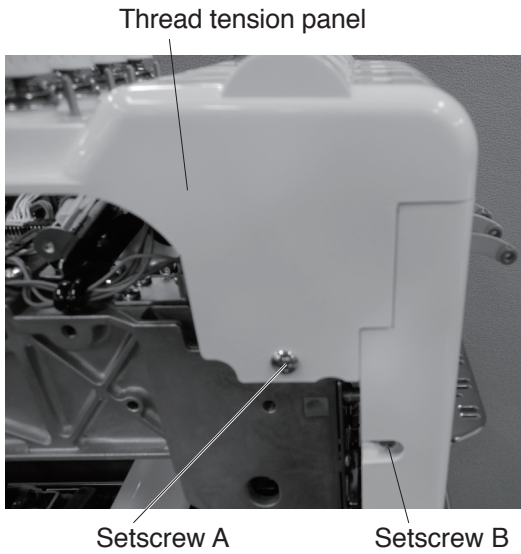

To remove:

1. Remove the setscrews A (2 pcs.) and thread tension panel.
2. Loosen the setscrews B (3 pcs.)

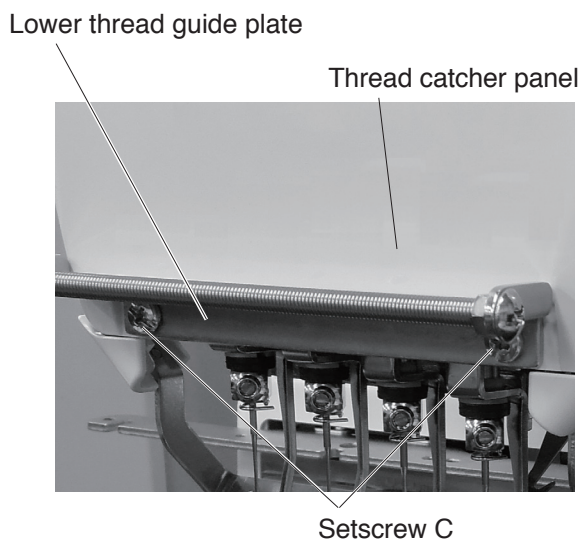
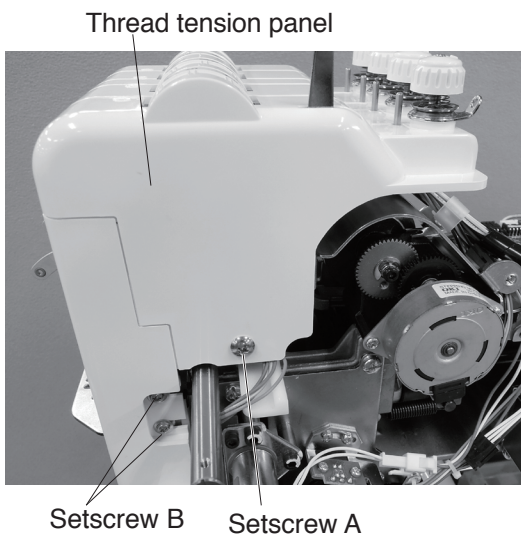

3. Remove the setscrews C, thread catcher panel and lower thread guide plate.

Checking the Thread Paths (1)

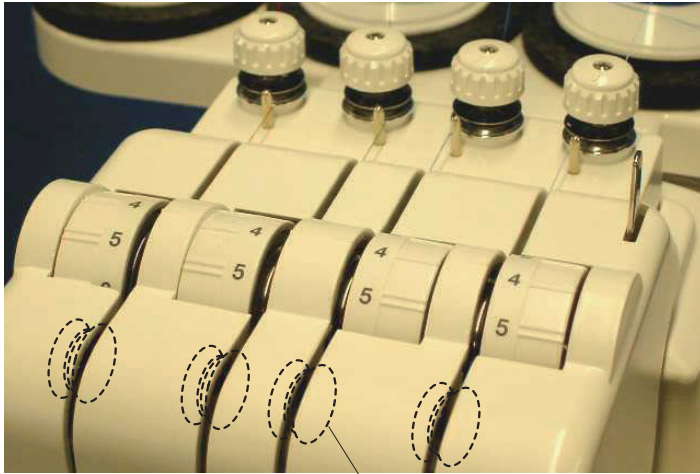

Detecting roller

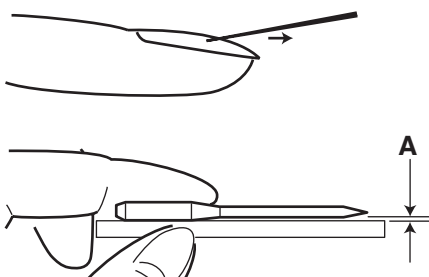

To avoid seam puckering, skipped stitches or thread breaking, keep the thread paths in the best condition.

1. **Tension control, detecting roller**
 - a) Detecting rollers should spin smoothly.
 - b) Tension controls and detecting rollers should be free from lint or dust.

2. **Thread guide hole**
 - a) There should be no burrs or scratches.

3. **Thread take-up lever**
 - a) There should be no burrs or scratches.

4. **Lower guide plate**
 - a) There should be no burrs or scratches.

5. **Needle**
 - a) Needles should not be bent or blunt.

To check the needle:

Touch the tip of the needle and slide it over on your nail and slid it lightly.

The needle must be blunt if there is any scratch on your nail after sliding the needle on your nail.

In that case, replace the needle.

Place the flat side of the needle onto something flat (needle plate, glass, etc.). The gap (A) between the needle and the flat surface should be consistent. Replace the needle if the gap is not consistent.

Checking the Thread Paths (2)

Upper side

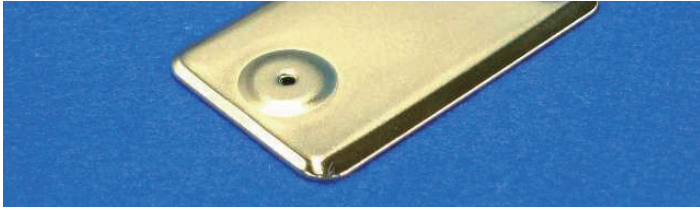

6. Needle plate
 - a) There should be no burrs or scratches.

Lower side



7. Presser foot
 - a) There should be no burrs or scratches, especially inside of the presser foot hole.
 - b) There should be no warp in the presser foot.



8. Hook race
 - a) There should be no burrs or scratches.
 - b) The tip of hook race should not be blunt.
 - c) There should be no detectable play in the hook and hook race.

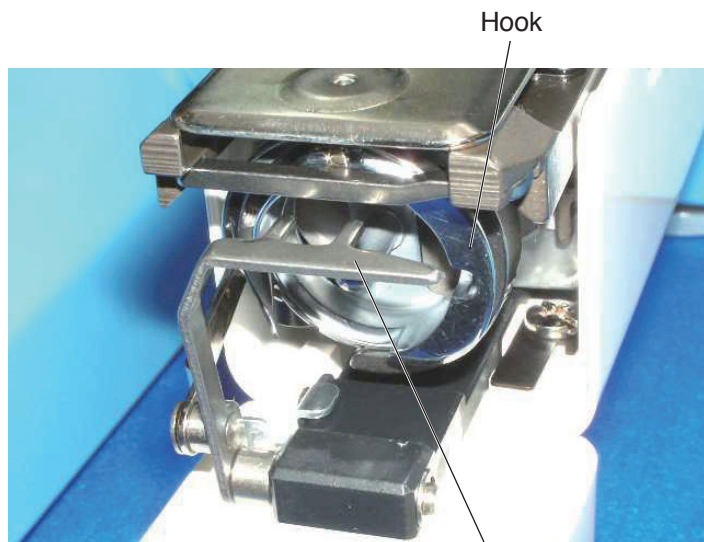

9. Thread keeper
 - a) There should be no burrs or scratches, especially on the tip of the thread keeper.

Thread keeper



10. Check spring
 - a) The check spring should not be worn.

Replacing the Needle

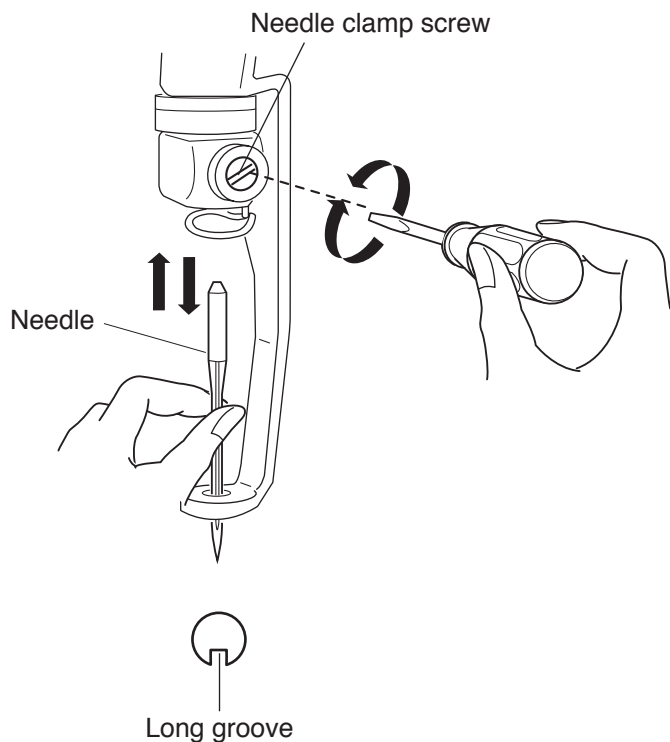

To remove:

1. Loosen the needle clamp screw.
2. Remove the needle.

To attach:

3. Insert the needle into the needle clamp with the long groove facing you. Push the needle up as far as it will go.
4. Tighten the needle clamp screw.

Needle and Thread Reference Table

Use DBxK5Q1NY needles and select an appropriate size of needle for threads and fabrics to be sewn.

An inappropriate size of needle may cause skip stitches, thread breakage or loose seam.

Please see the table below and select the suitable needle size.

Thread Size (Denier) Polyester	Needle Size
75	8 to 10
120	9 to 11
200	11 to 14

Adjusting the Bobbin Thread Tension

1

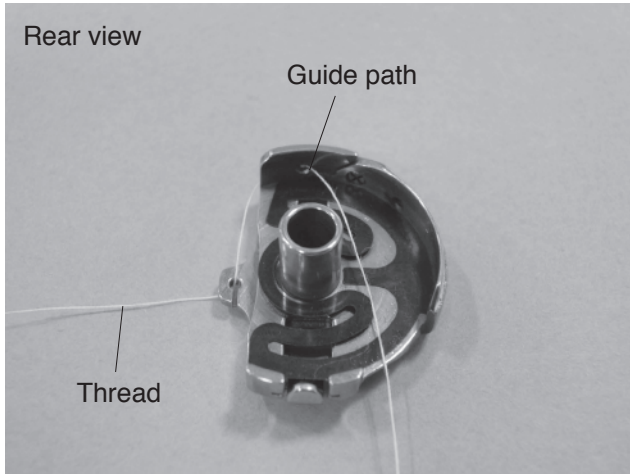

* Use cotton thread size 120.

1. Guide the thread to the left to pass it into the guide path as shown.

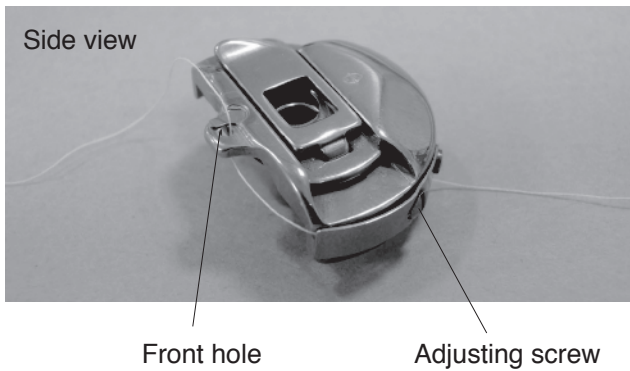

2

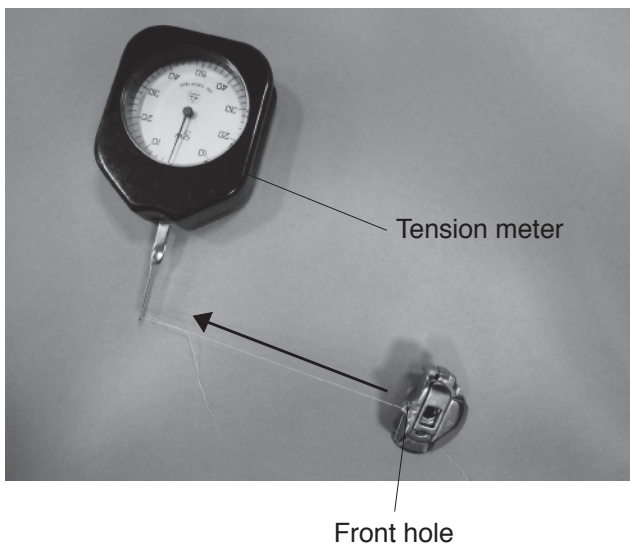

2. Pulling the thread from the front hole in the direction of arrow, measure the thread tension with a tension meter.
The thread tension should be in the range of 20 to 30 grams-force.
If not, adjust the thread tension by turning the adjusting screw.

Checking the Lowest Position of the Needle

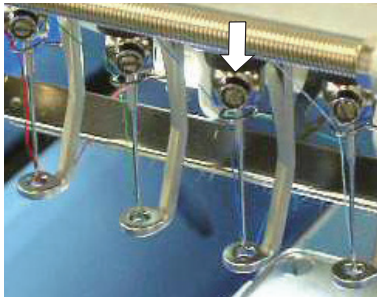
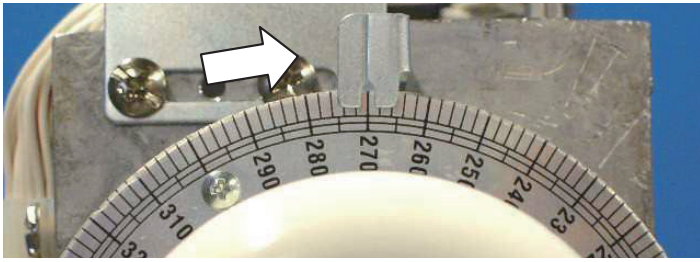

1. Remove the spool stand, head set right cover (unit right cover and left cover (see pages 5 to 6).

2. Turn the handwheel to set the index disk at 270°.

3. Push the needle bar down to engage the needle bar clutch.

4. Turn the handwheel to set the needle bar at its lowest position.
Use a lever type dial indicator to measure the needle bar height.

5. Turn the handwheel clockwise until the indicator reads 0.2 mm and read the angle (A°) of the index disk.
Turn the handwheel counterclockwise until the indicator reads 0.2 mm and read the angle (B°) of the index disk.

Calculate the mean angle (C°): $C = (A + B - 360) \div 2$

Turn the handwheel clockwise to set the index disk at C°.

Loosen the setscrews (2 pcs.) and set the pointer at 0° (L). Tighten the setscrews (2 pcs.) securely.

Check the following items if you have adjusted the lowest position of the needle.

- Upper shaft timing
- Take-up lever timing
- Hook timing
- Thread cutter timing

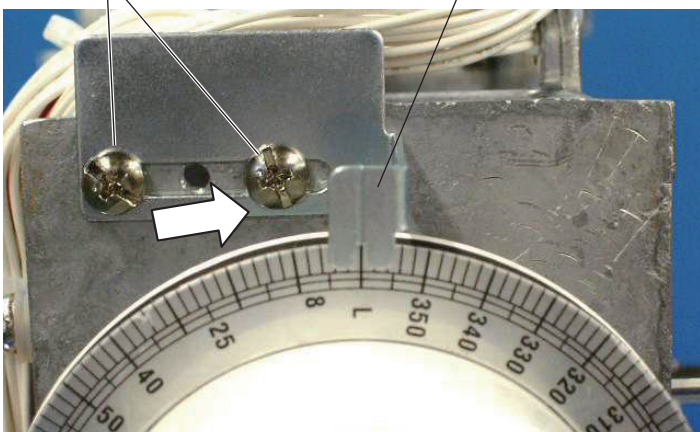
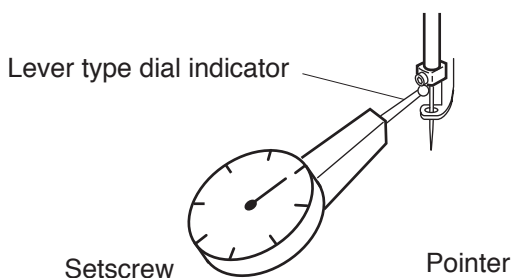

Replacing the Needle Bar Rest

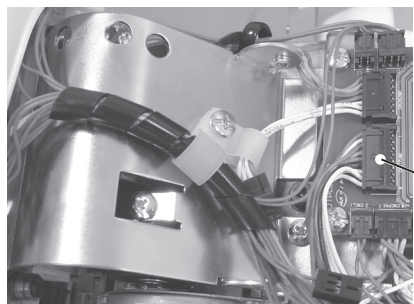

Thread catcher unit connector

To remove:

1. Remove spool stand, head set right cover (unit), lateral moving unit, right cover and left cover.
2. Disconnect the thread catcher unit connector. Remove the setscrews A (2 pcs.) and setscrew B. Remove the thread catcher unit.

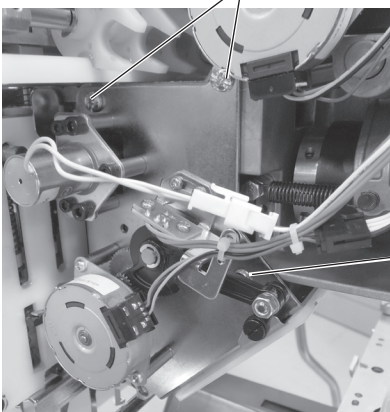

Setscrew A

Setscrew B

3. Loosen the setscrew C. Pull the main shaft up and remove it from the machine.

Setscrew C

Main shaft

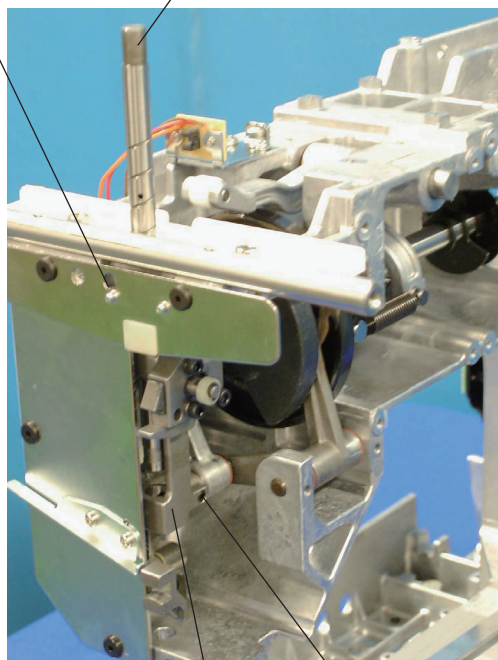

4. Loosen the setscrew D and remove the needle bar rest from the main shaft.

Needle bar rest

Setscrew D

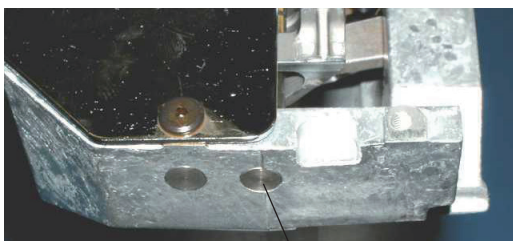

Bottom of the head frame

To attach:

5. Reverse the procedure above. Attach the needle bar main shaft so its bottom end is level with the bottom surface of the head frame.
6. Adjust the needle height after the replacement.

Replacing the Take-up Lever Cam Roller

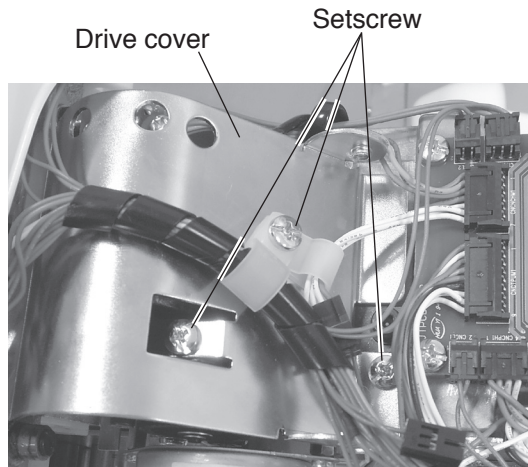

Thread take-up lever spring



Setscrew

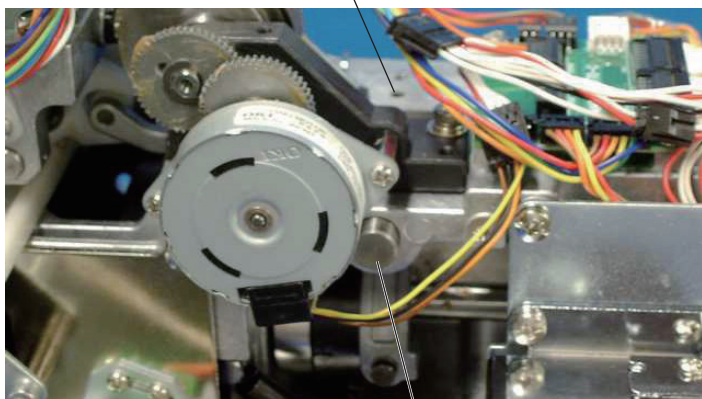

Thread take-up lever shaft Thread take-up lever shaft Thread take-up lever unit

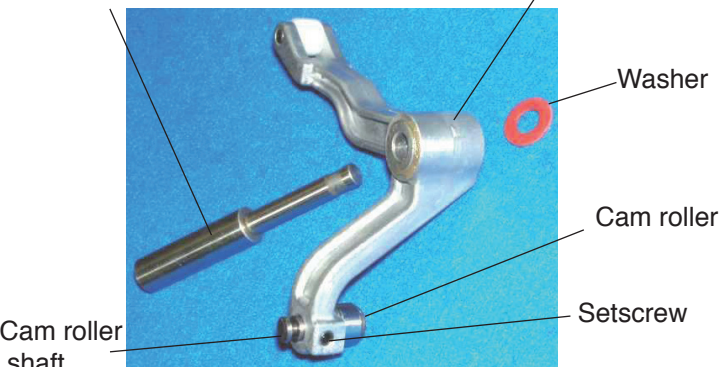

To remove:

1. Remove spool stand, head set right cover (unit), right cover, left cover and thread tension panel. (see pages 4 to 6 and 8).
2. Remove the setscrews (3 pcs.) and drive cover.

3. Remove the thread take-up lever spring with pliers.

4. Loosen the setscrew. Remove the thread take-up lever shaft, thread take-up lever unit and washer.

5. Loosen the setscrew. Remove the cam roller shaft and cam roller.

To attach:

6. Reverse the procedure above. When attaching the thread take-up lever shaft, tighten the screw while pressing the thread take-up lever shaft lightly.

Adjusting the Take-up Lever Timing

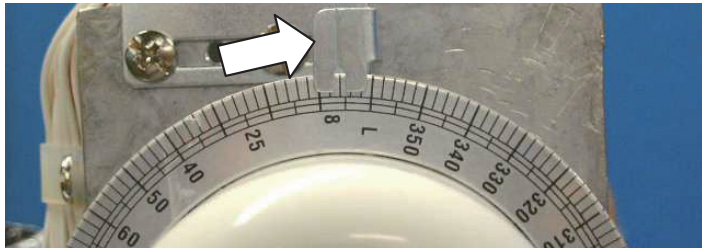

To remove:

1. Remove spool stand, head set right cover (unit), right cover and left cover.
2. Turn the handwheel to set the index disk at 6°.
3. Insert the positioning pin from the left side of the arm. The positioning pin goes into the pin groove of take-up lever cam if the timing is correctly adjusted.

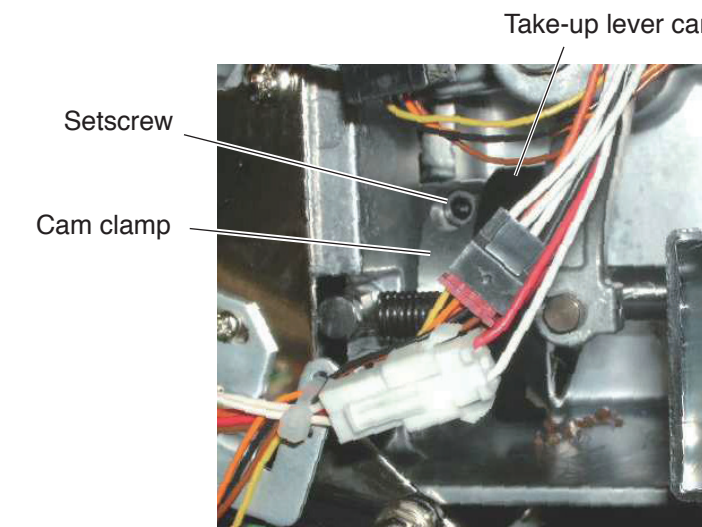
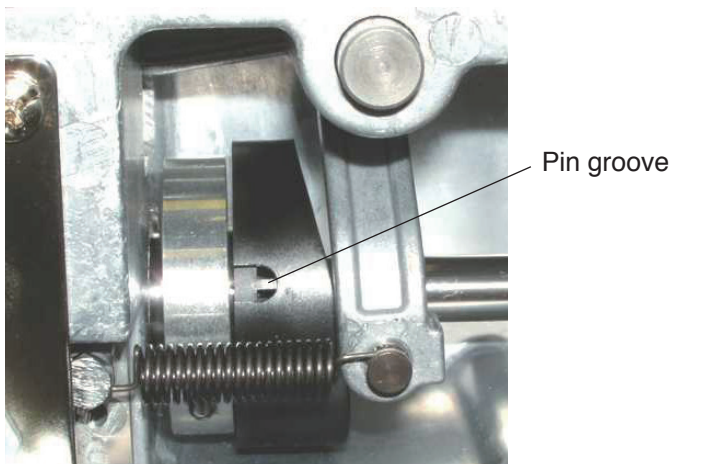
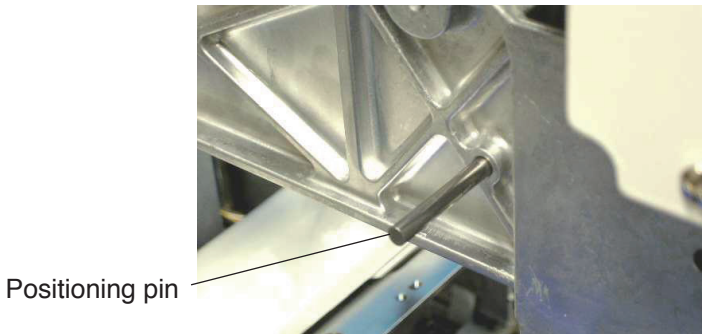

4. If the timing is incorrect, loosen the setscrew on the cam clamp and turn the take-up lever cam so the positioning pin can go into the pin groove on the cam. Turn the handwheel to set the index disk at 6°. Tighten the setscrew on the cam clamp while pressing the take-up lever cam to the side of the dynamic head. There should be no gap between the take-up lever cam and cam clamp.

5. Pull the positioning pin out from the arm. Turn the handwheel to set the index disk at 270°. Attach the removed parts.

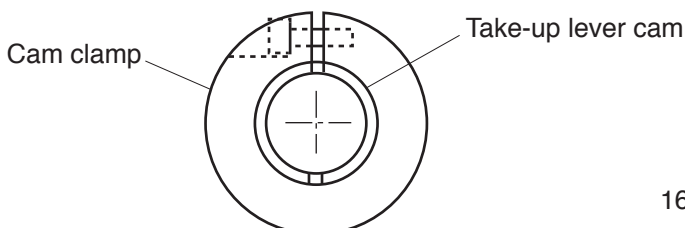

Replacing the Presser Foot Cam (1)

*You need to remove the crank when replacing the presser foot cam.

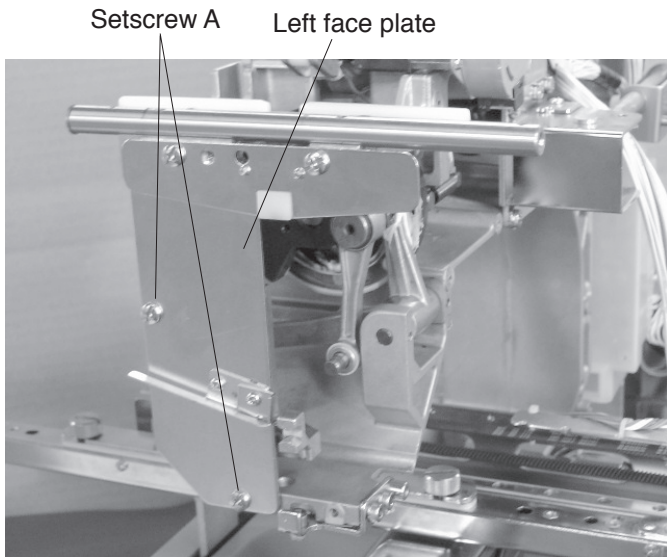

1. Remove the spool stand, head set right cover, right cover, left cover, moving head, thread catcher (unit) and needle bar rest.
 - * The lateral moving unit is not needed to remove.
2. Remove the setscrews A (2 pcs.) and the left face plate.

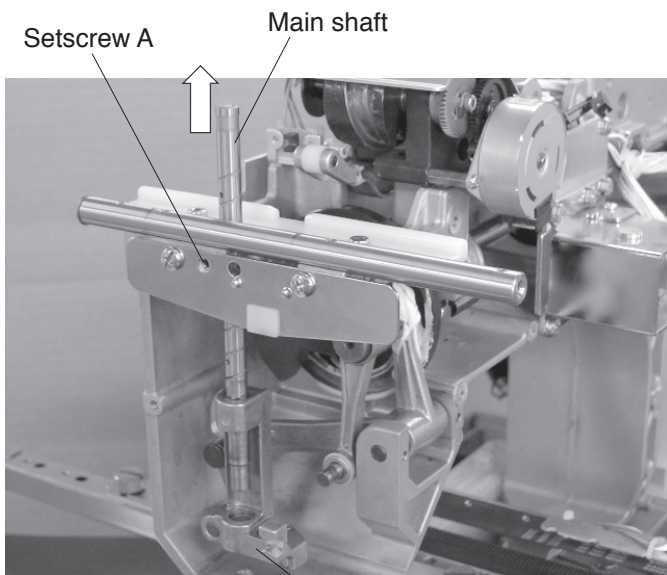

3. Loosen the setscrew A. Pull the main shaft up. Remove the presser foot block (unit).

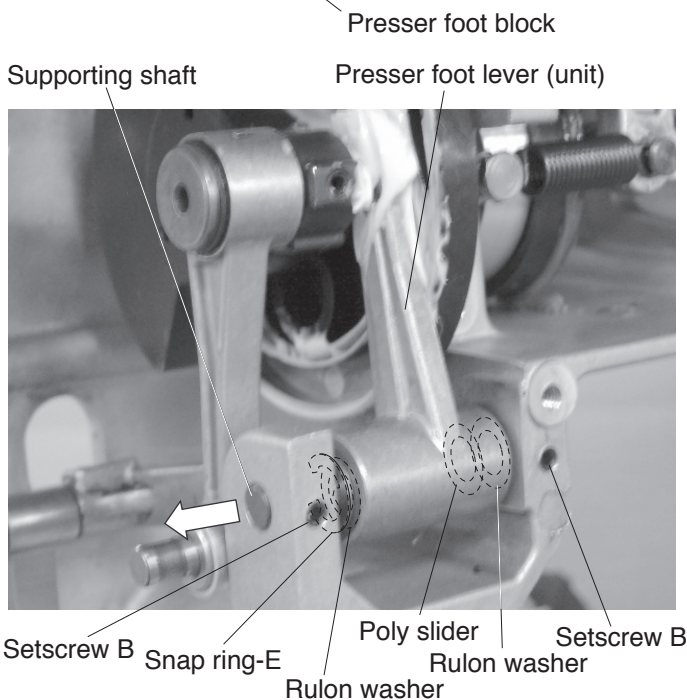

4. Remove the snap ring-E. Loosen the setscrews B (2 pcs.). Push the supporting shaft from the backside and pull the supporting shaft out to the front. Remove the presser foot lever (unit), poly slider and rulon washer.

Replacing the Presser Foot Cam (2)

Setscrew C

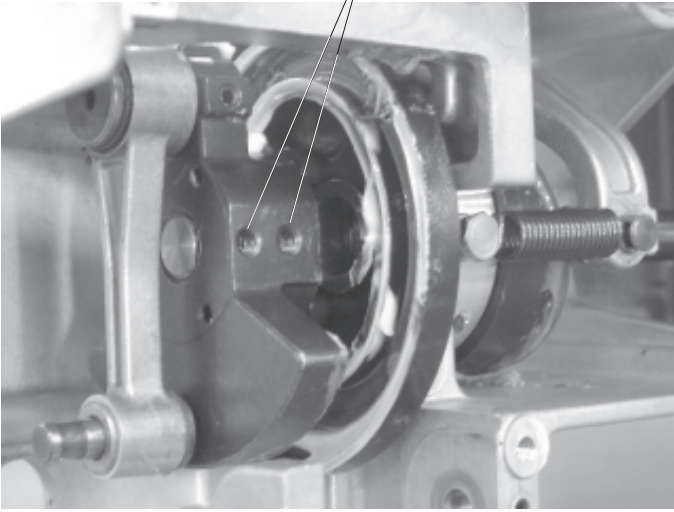

5. Loosen the setscrews C (2pcs.).

Crank (unit)

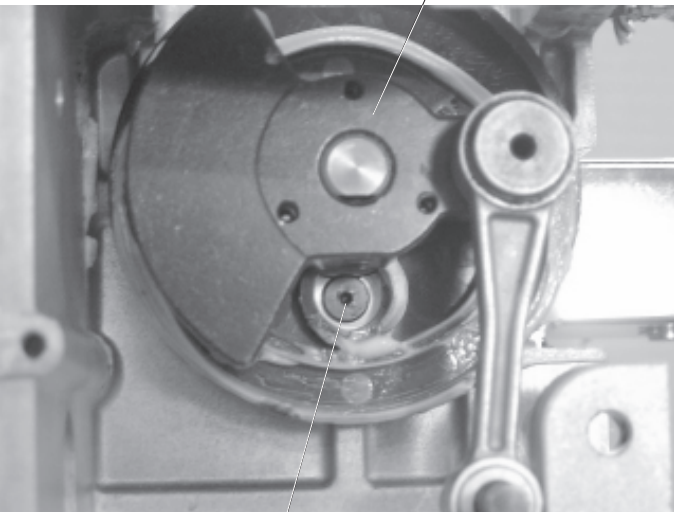

Setscrew B

6. Remove the setscrew B.
Pull the crank out to the front to remove it.

Replacing the Presser Foot Cam (3)



7. Apply the grease to the groove of the presser foot cam.
* Recommended grease: MOLYKOTE (R) EM-30L.
8. Reverse the procedure to reinstall the parts.
Do not attach the covers yet.
9. Check the lowest position of the needle (see page 13).
10. Adjust the position of the lateral moving unit (see page 40).
11. Attach the covers according to the procedures.

Replacing and Adjusting the Presser Foot (1)

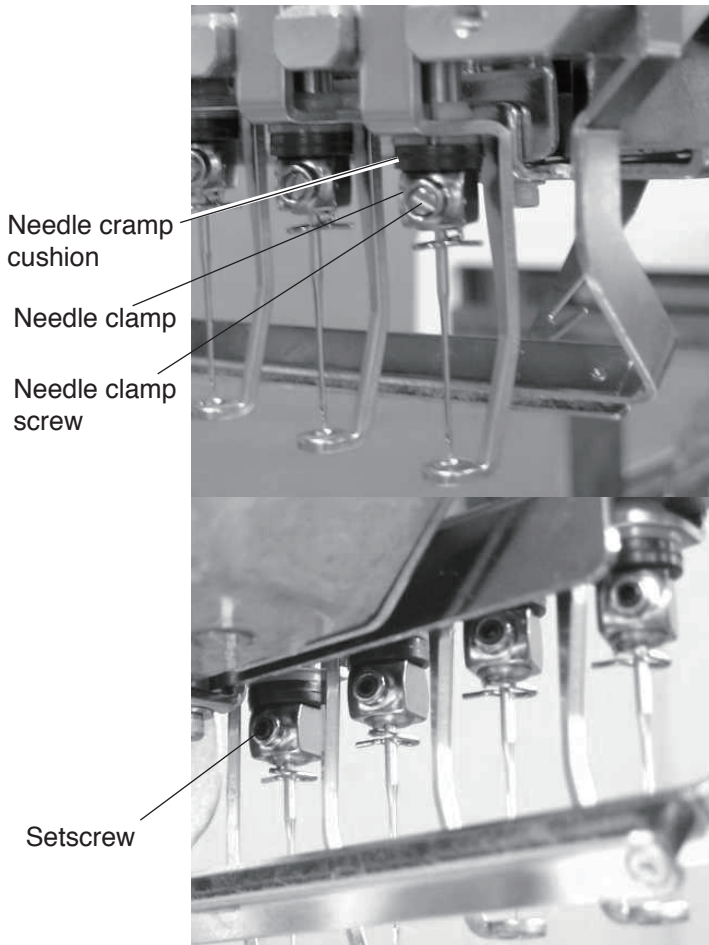

1. Remove the lower thread guide plate unit and thread catcher panel. (see page 8)
2. Loosen the needle clamp screw and the setscrew. Remove the needle, needle clamp and needle clamp cushions (2 pcs.).

NOTE:

The presser foot will spring down when the needle clamp is removed.

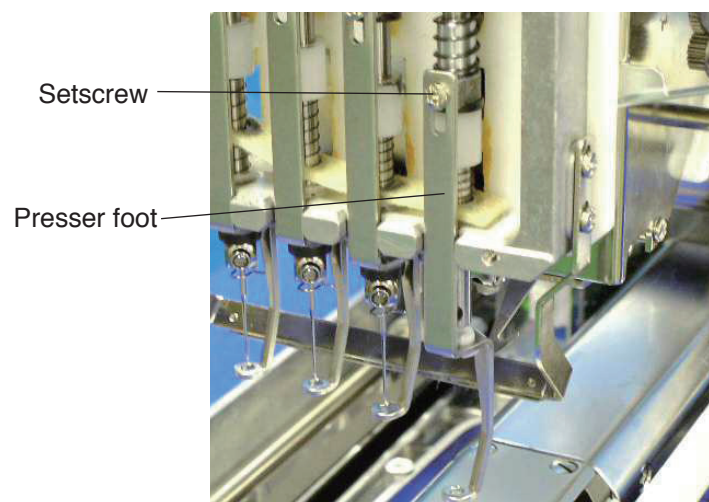

3. Remove the setscrew and replace the presser foot.
4. Attach the needle, needle clamp and needle clamp cushions. Tighten the needle clamp screw and setscrew.
5. Adjust the needle height. (see Adjusting the needle height) (see page 32.)

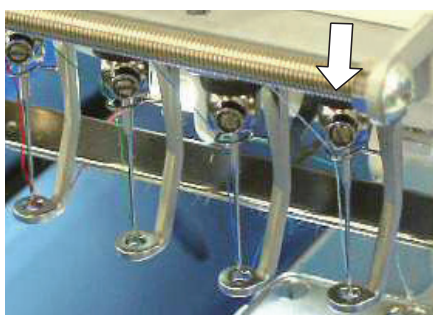

6. Push the needle bar down to engage the needle bar clutch.

Replacing and Adjusting the Presser Foot (2)

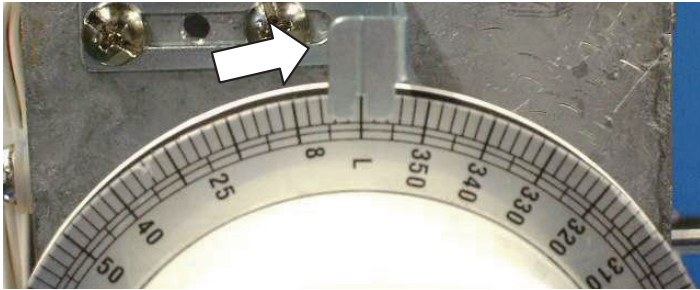

7. Turn the handwheel to set the index disk at 0° (L).



8. Insert the 1.2 mm thick gauge between the needle plate and the presser foot.

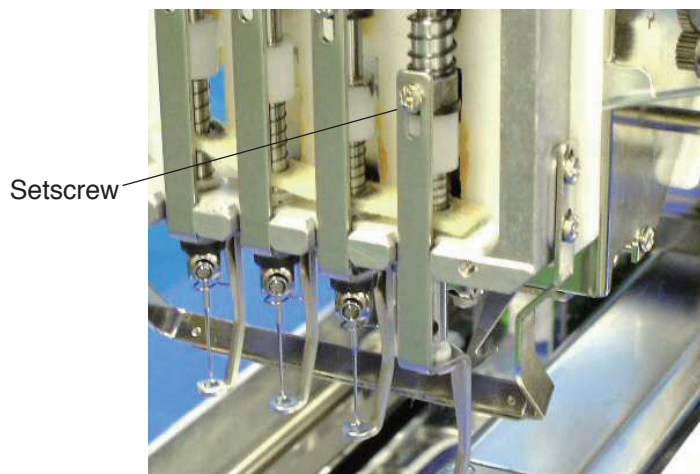

9. Tighten the setscrew.

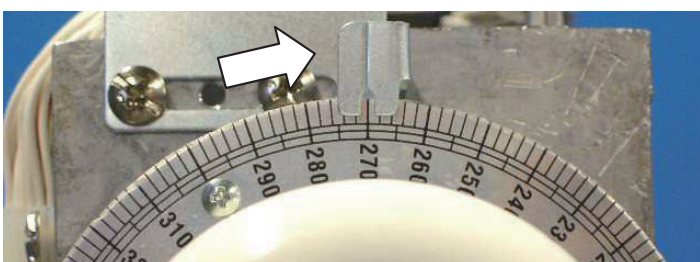

10. Turn the handwheel to reset the index disk at 270°.

11. Attach the removed parts.

Replacing the Presser Foot Return Spring and Washer (1)

Step 1: Open the Needle Change Adjusting Window of the Factory Adjusting Mode.

Turn the power switch on while pressing the Start/ Stop button and Thread cutter button at the same time to open the Factory Adjusting window.

Select needle bar No. 1.

Step 2: Removing the Needle Bar

1. Remove the thread tension panel, lower thread guide plate and thread catcher panel (see page 8).

2. Remove the 2 setscrews A and the tension control unit.

3. Loosen the needle clamp screw and remove the needle.

4. Lower the needle bar. Loosen the hexagonal socket screw and remove the needle clamp.

5. Remove the setscrew B, presser foot and cushion.

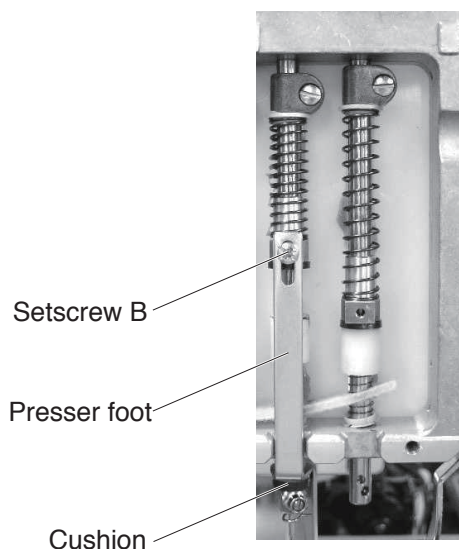
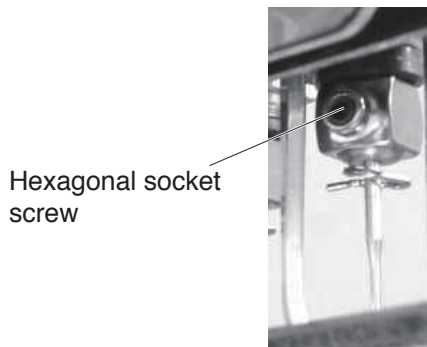
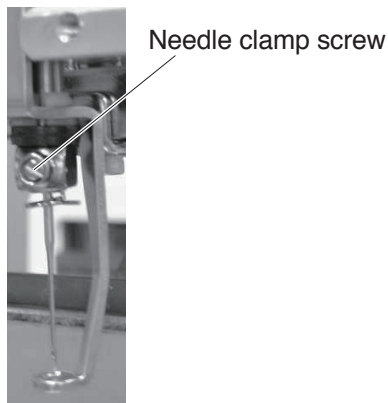
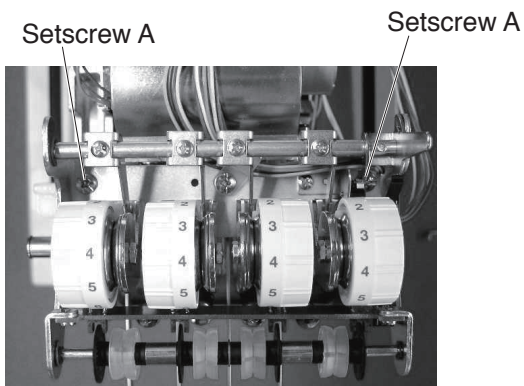

Replacing the Presser Foot Return Spring and Washer (2)

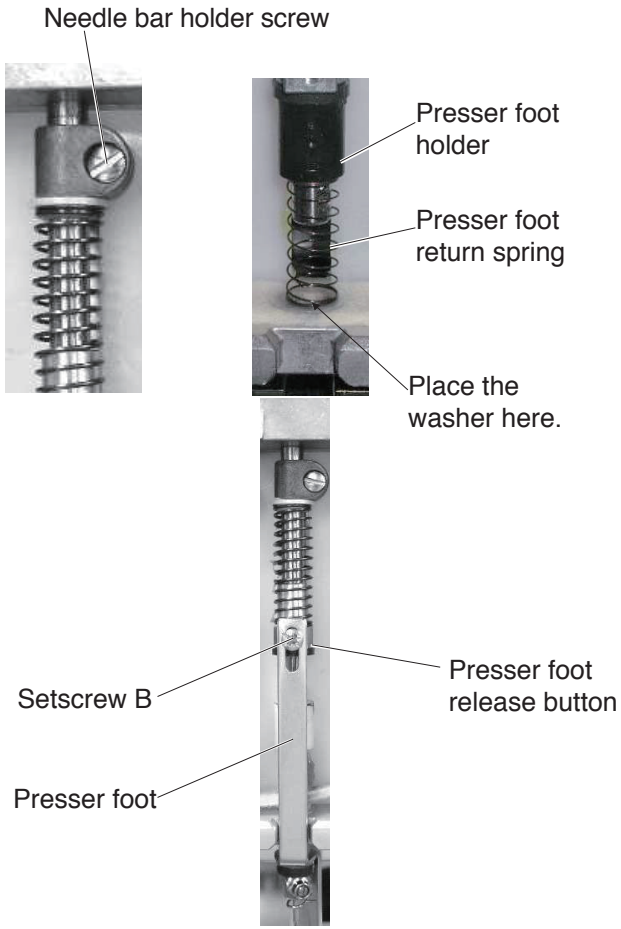

6. Loosen the needle bar holder screw.
Pull the needle bar up until the bottom end of the needle bar reaches the bottom end of the presser foot holder.
Note: Do not pull the needle bar out of the frame.
7. Replace the white plastic washer with the metal washer.
Replace the presser foot return spring with the new spring (closed end coil).
8. Attach the presser foot to the presser foot release button with the setscrew B.
Tighten the setscrew B partially.

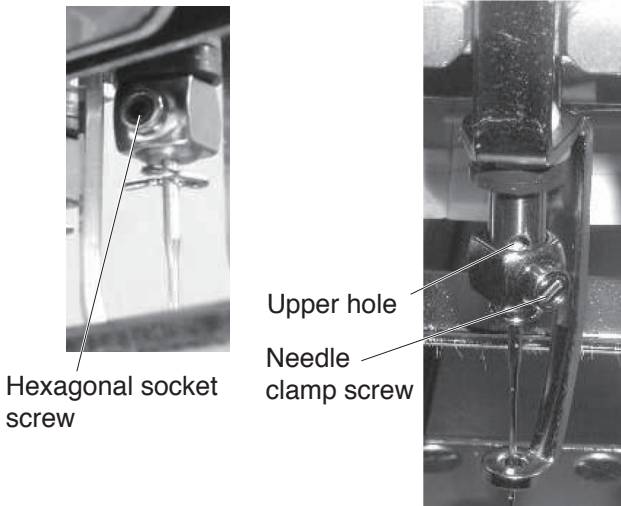

9. Attach the cushion and needle clamp to the needle bar.
10. Turn the needle bar so the upper hole faces front and the needle clamp screw faces 30 degrees right to the front.
Tighten the needle clamp screw through the needle clamp and into the lower hole in the needle bar.
Insert the needle with the long groove facing front (in line with the upper hole).
11. Tighten the needle clamp screw lightly while pressing the needle clamp down.
Turn the hand wheel to lower the needle bar at its lowest position. Hold the needle clamp with your fingers and tighten the hexagonal socket screw securely.
Tighten the needle clamp screw securely.

Note: The long groove of the needle should face front.

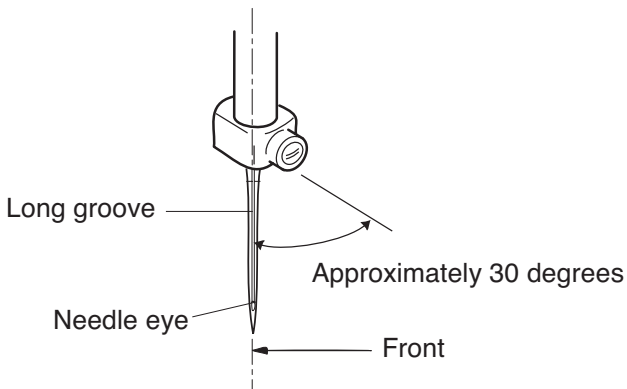

Replacing the Presser Foot Return Spring and Washer (3)

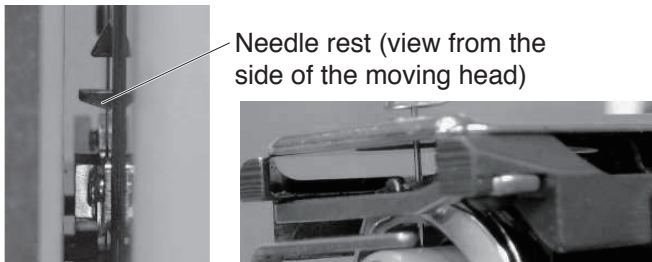

Needle bar height gauge



Needle bar holder screw

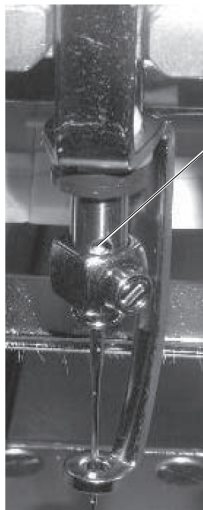

Hole in the needle bar

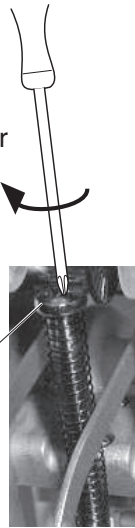

Thickness gauge (1.2 mm)



Setscrew B

Presser foot



Step 3: Adjusting the Height of the Needle Bar and Presser Foot

12. Remove the bobbin case.
 13. Hold the needle bar holder and push the needle bar down until it clicks.
 14. Lower the needle bar to the lowest position by turning the hand wheel.
 15. Insert the needle bar height gauge into the hook.
 16. Knock on the top of the needle bar gently until the tip of the needle contact the gauge lightly.
Turn the gauge to find if the needle reaches the gauge. Set the direction of the needle bar so the hole in the needle bar faces directly the front.
 17. Tighten the needle bar holder screw securely.
- Note:** Check if the needle bar is securely fixed by turning the cap screw clockwise.
18. Loosen the setscrew B.
 19. Insert the 1.2 mm thickness gauge between the presser foot and needle plate. Press the presser foot down against the gauge.
 20. Tighten the setscrew B securely.
 21. Remove the needle bar height gauge.
 22. Turn the hand wheel to match the alignment line on it with the joint of the right and left covers (the upper shaft will be set at 270 degrees).

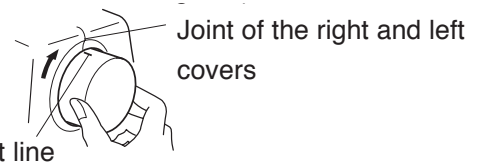

- * To replace the spring and washer on other needle bars, follow the above steps (select the relevant needle bar in the needle change adjusting window).

23. Attach the tension control unit and thread catcher panel. Lower thread guide plate and thread tension panel.

Note: Be sure not to get wires caught between covers. Adjust the position of the thread tension panel so the arch of the cover aligns with the tension dials.

Step 4: Test Sewing

Insert the test pattern card into the RCS unit and sew the test pattern.

Use a 120 deniers rayon thread or equivalent for needle and a #120 cotton or polyester thread for bobbin.

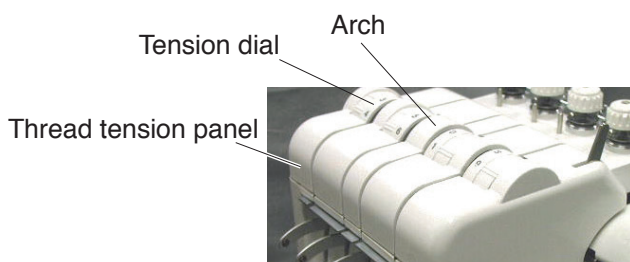

Replacing the Thread Catcher

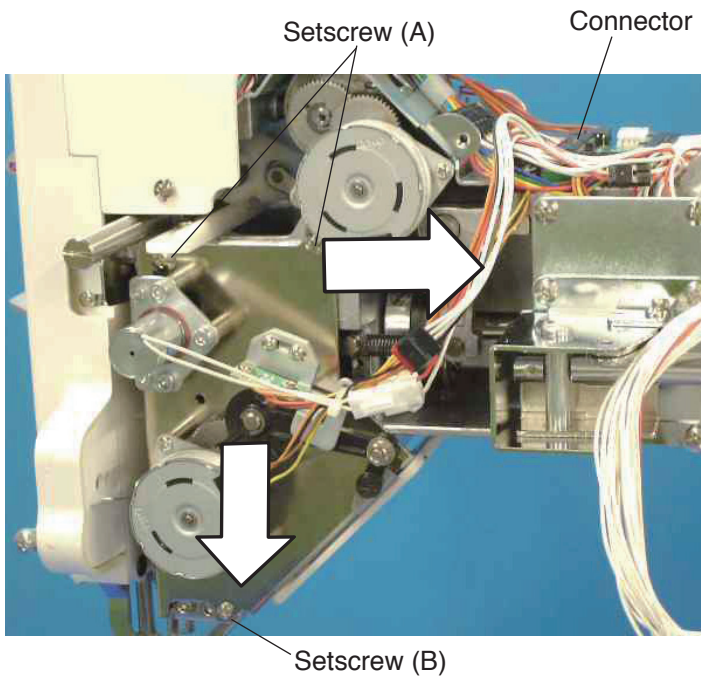

To remove:

1. Remove spool stand, head set right cover (unit), right cover, left cover, moving head. (see page 4)
2. Disconnect the thread catcher connector. Remove the setscrews A (2 pcs.), setscrew B and the thread catcher.

To attach:

3. Connect the thread catcher connector. Tighten the setscrews A and setscrew B while pressing the thread catcher unit in the direction of arrows as illustrated.
4. Adjust the thread catcher (see page 38).
5. Attach the removed parts.

Replacing the Thread Catcher Hook

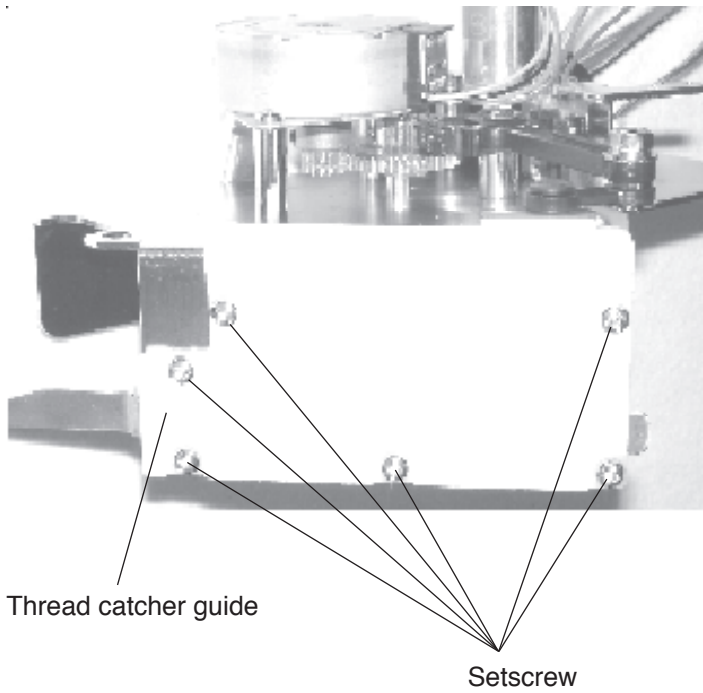

To remove:

1. Remove the thread catcher unit (see page 25).
2. Loosen the setscrews (6 pcs.) and remove the thread catcher guide.
3. Remove the thread catcher hook screw.
Remove the thread catcher hook.

To attach:

4. Attach the thread catcher hook with the thread catcher hook screw.
5. Attach the thread catcher guide with the setscrews. (6 pcs.)
6. Attach the thread catcher unit (see page 25).

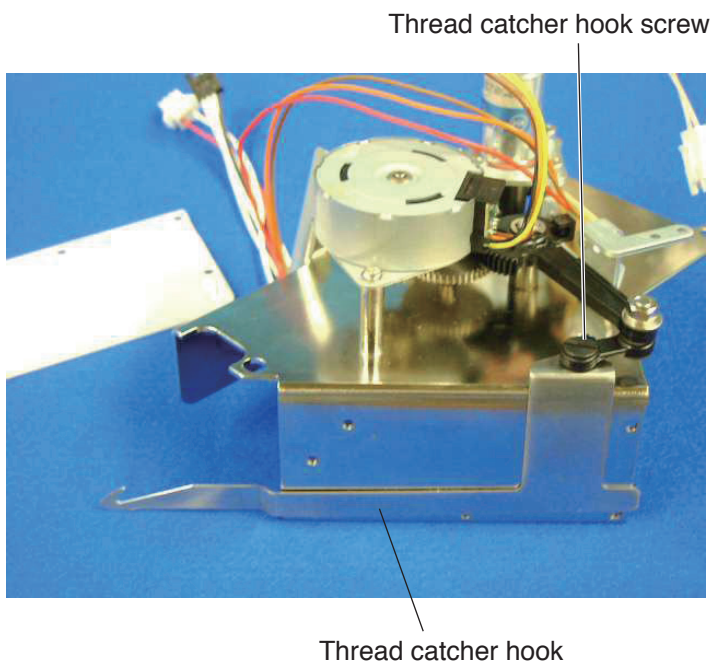

Replacing the Jump Solenoid

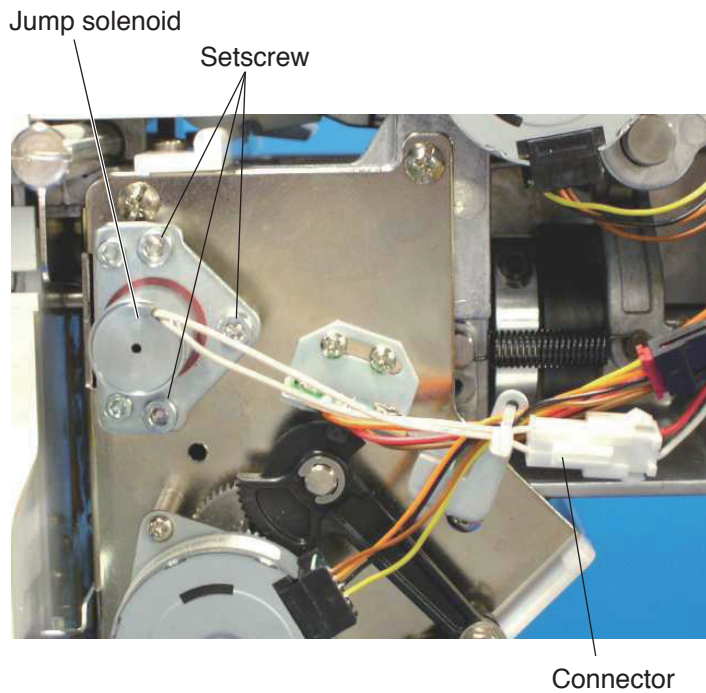

1. Remove the head set right cover (unit)(see page 5).
2. Disconnect the connector. Remove the setscrews (3 pcs.) and jump solenoid.

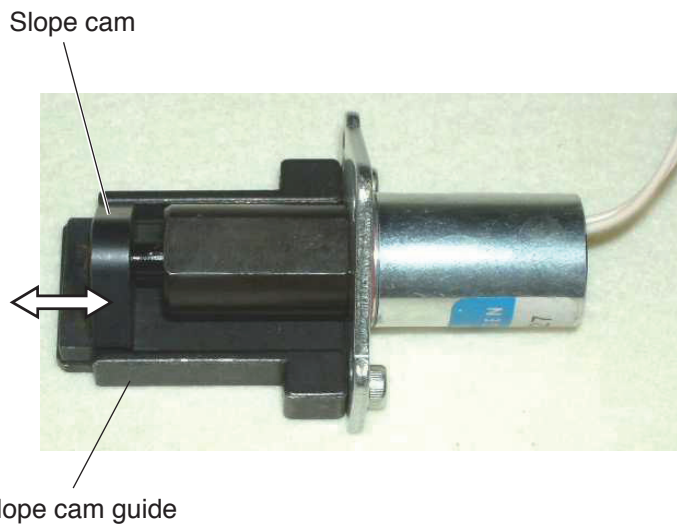

3. The slope cam should slide on the slope cam guide smoothly. Clean the solenoid if there is any lint or dust on it.

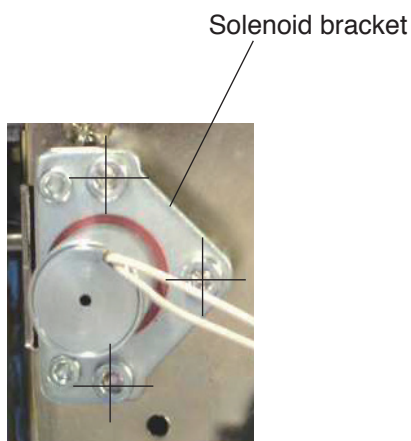

4. Attach the jump solenoid to the machine. Tighten the setscrews. The setscrews should be positioned at the center of holes as shown.
5. Attach the head set right cover (unit).

Adjusting a Play in the Moving Head

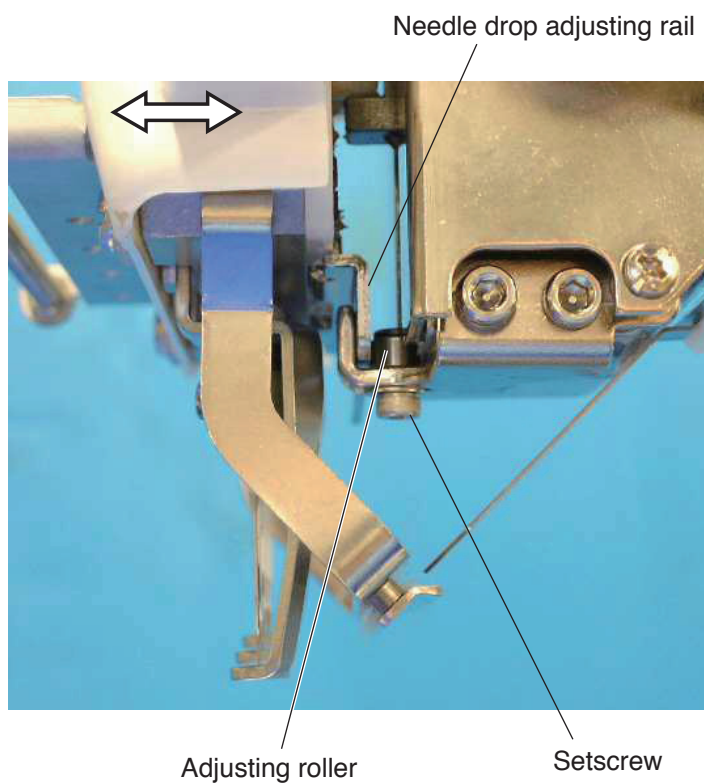

1. Remove head set right cover (unit) (see page 5).
2. Check the play of the moving head by pushing the head in the direction of the arrows.
If there is a detectable play, loosen the setscrew and tighten it while pressing the adjusting roller against the needle drop adjusting rail.

3. Adjust the needle drop position (see page 31).
4. Attach the head set right cover (unit).

Replacing the Moving Head (1)

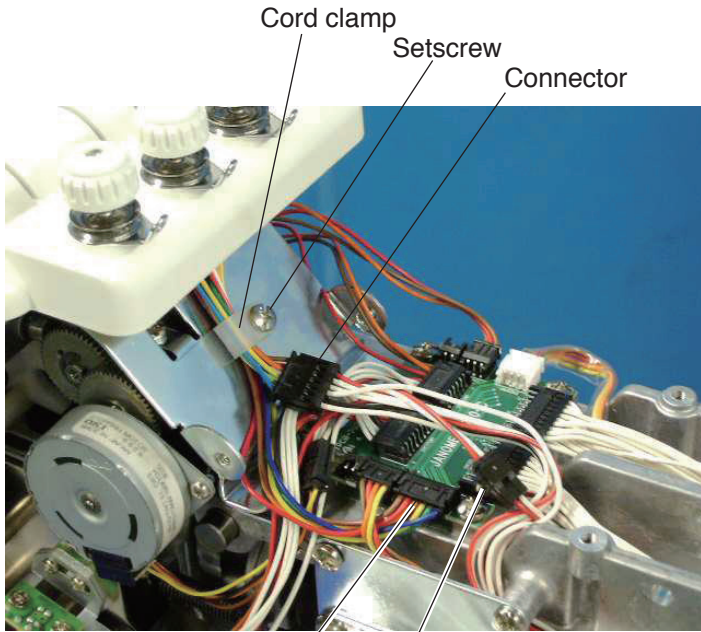

Connector Connector

To remove:

1. Remove the spool stand, head set right cover (unit), right cover and left cover.
2. Disconnect the connectors. Remove the setscrew of the cord clamp.

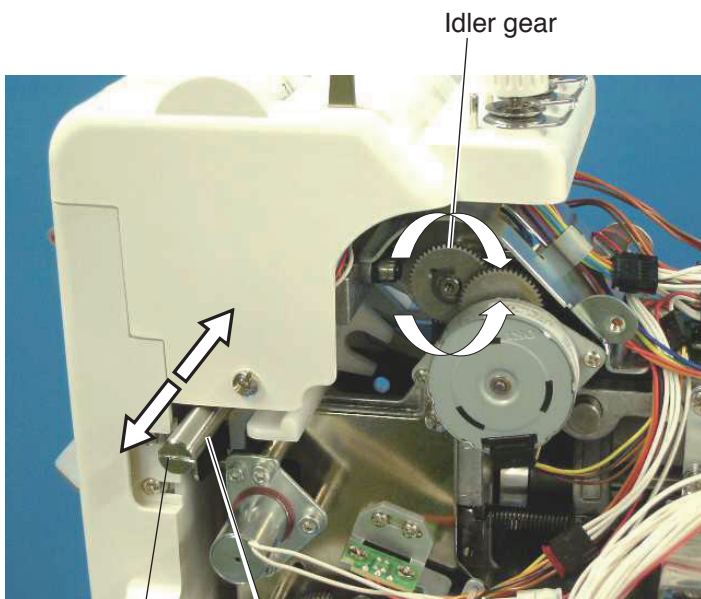

Stopper screw Rail shaft

3. Remove either the left or right side of stopper screw on the rail shaft.
4. Turn the idler gear to move the moving head to the end of the rail shaft with the stopper screw removed. Support the moving head securely while removing the moving head so as not to fall.

To attach:

5. Attach the moving head. Tighten the stopper screw.

Replacing the Moving Head (2)

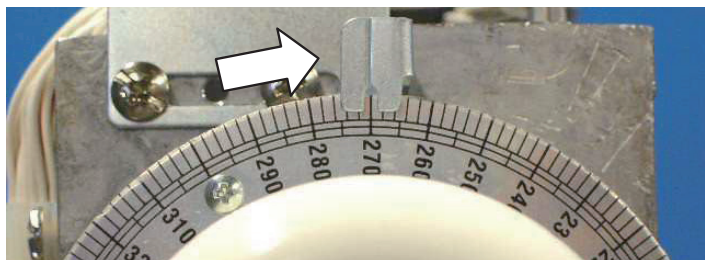

6. Turn the handwheel to set the index disk at 270°.

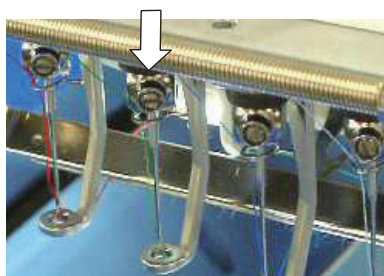

7. Turn the idler gear to set the moving head to the needle bar No. 3.
Push the needle bar No. 3 down to engage the needle bar clutch.

8. Turn the handwheel until the needle goes into the needle hole.



9. Check the needle drop position. The needle drop position should be the center of the needle hole.

If the needle drop position is off position to the front or rear, adjust the needle drop position (see the next page).

If the needle drop position is off position in the lateral direction, adjust the position of the lateral moving head (see page 40).

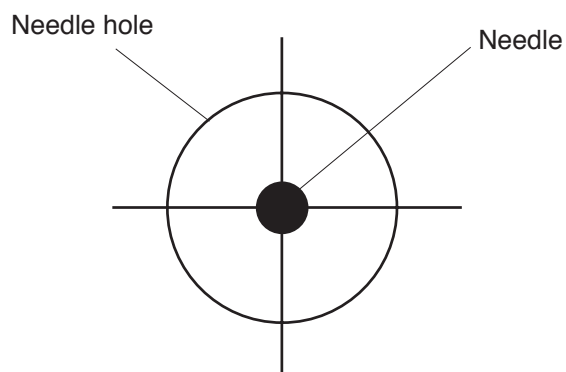

10. Turn the handwheel one complete turn to set the index disk at 270°

11. Connect the connectors and attach the parts removed.

Adjusting the Needle Drop Position (Back or Forth)

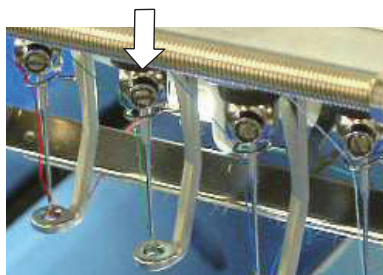

1. Set the moving head to needle bar No. 3 (see "Needle bar number setting" of the instruction book). Push the needle bar No. 3 down to engage the needle bar clutch.

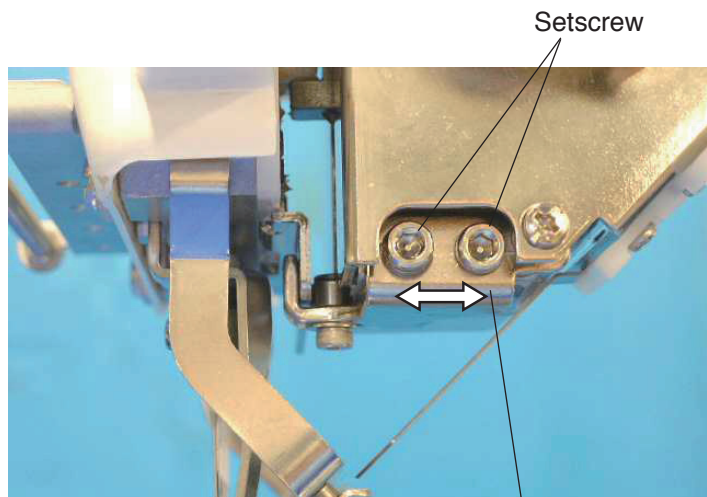

2. Turn the handwheel until the needle goes down into the needle hole. Loosen the setscrews (2 pcs.). Adjust the needle drop position adjusting plate. Center the needle drop position in the needle hole.

3. Adjust the hook timing (see page 41).

Needle drop position adjusting plate

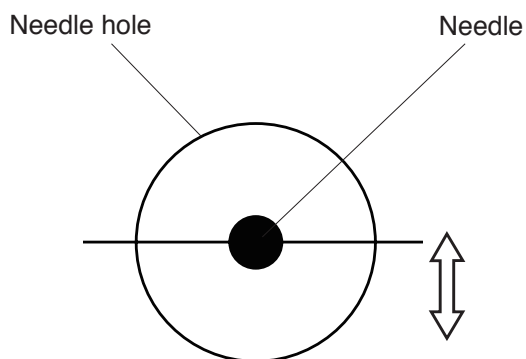

Adjusting the Needle Height

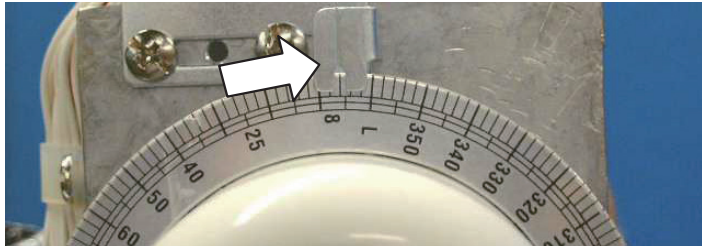
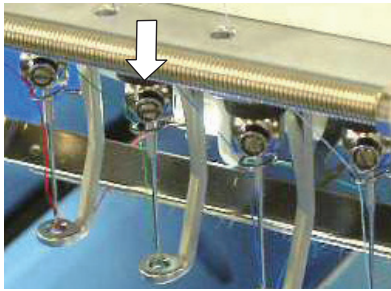

Setscrew

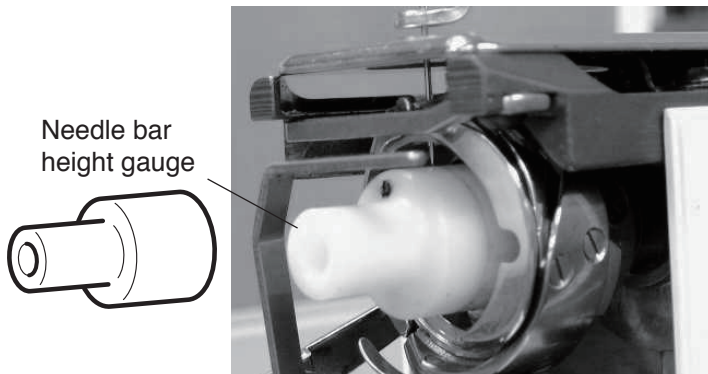

Needle bar height gauge

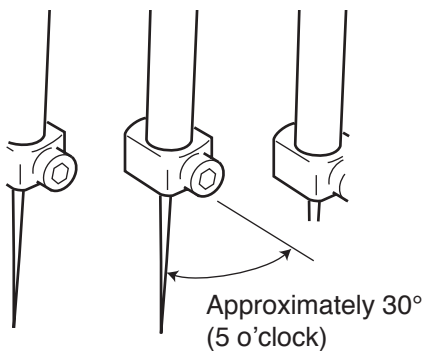

1. Remove the lower thread guide plate and thread catcher panel. (see page 8)
2. Remove the bobbin case.
3. Push the needle bar down to engage the needle bar clutch.
4. Turn the handwheel to set the index disk at 5°.
5. Loosen the needle bar supporter screw.
6. Insert the needle bar height gauge into the hook.
7. Adjust the needle bar height so the tip of needle slightly touches the gauge.
8. Adjust the direction of needle clamp as illustrated below (the needle clamp screw is at 5 o'clock). Tighten the setscrew.
9. Remove the needle bar height gauge.
10. Turn the handwheel to set the index disk at 270°.
11. Attach removed parts.

Replacing the Needle Bar, Needle Spring and Cushion

1. Remove the presser foot (see pages 20 and 21).

2. Loosen the needle bar holder screw.

3. Pull the needle bar up and out of the frame.
To remove the parts on the needle bar, pull the needle bar as far as the desired part can be removed.

4. Insert the needle bar down into the frame and put the parts on the needle bar as it goes.

5. Attach the presser foot.

6. Adjust the needle height (see page 32).

7. Adjust the presser bar height (see pages 20 and 21).

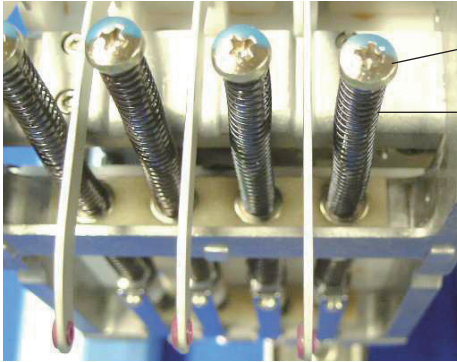

Needle bar

Needle bar spring

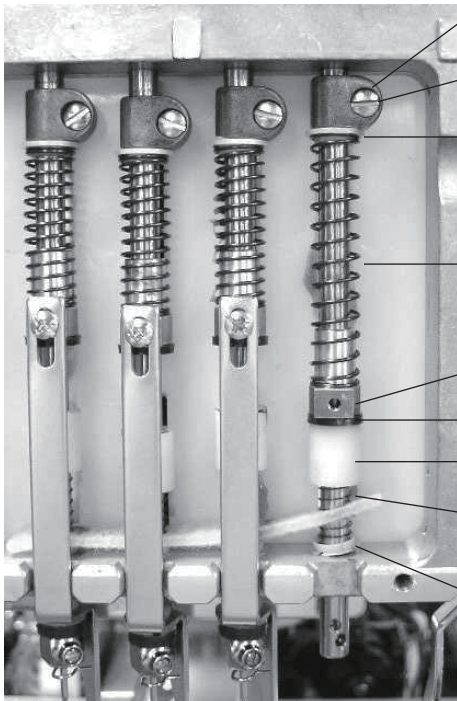

Needle bar holder

Needle bar holder screw

Spring base

Presser foot spring (lower)

Presser foot block

Stop felt

Presser foot holder

Presser foot return spring

Lower felt base

Replacing the Rotation Stopper Plate

To remove:

1. Remove moving head (see pages 22 and 23).
2. Remove the setscrews (6 pcs.) and rotation stopper plate.

To attach:

3. Attach the rotation stopper plate with the setscrews (6 pcs.).
The setscrews should be positioned at the center of each holes when tightening each setscrews.
4. Attach moving head.

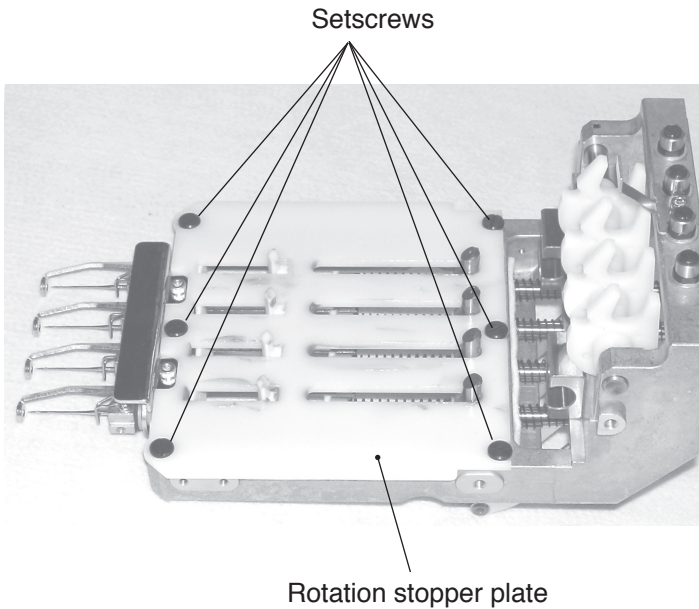

Replacing the Thread Take-up Lever

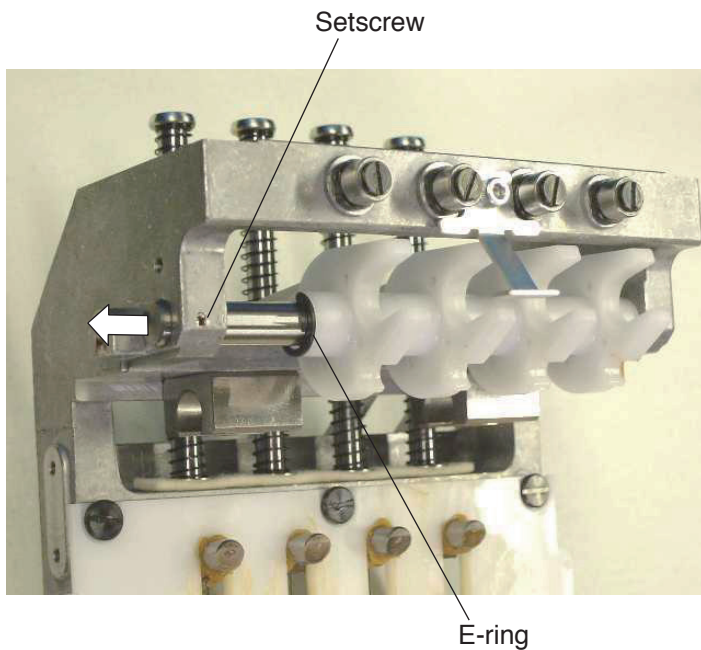

1. Remove moving head (see pages 29 and 30).
2. Remove the E-ring.
3. Loosen the setscrew on the thread take-up lever shaft.
4. Pull the thread take-up lever shaft out in the direction of the arrow. Remove the thread take-up lever to replace.
5. Replace the thread take-up lever.
6. Attach the E-ring.

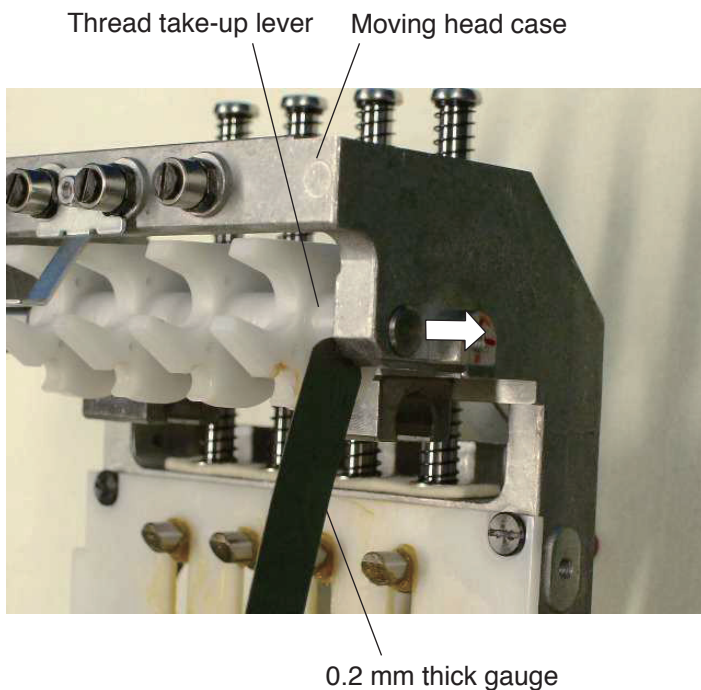

7. Insert a 0.2 mm thick gauge between the moving head case and thread take-up lever. Tighten the setscrew while pressing the thread take-up lever shaft in the direction of the arrow.
8. Attach the moving head.

Adjusting the Check Spring Tension



Setscrew B

Setscrew C

Lower thread guide plate

Setscrew A

Check spring tension is not necessary to adjust under normal conditions. However, you need to adjust the tension of the check spring when it is replaced.

1. Remove the setscrews A (2 pcs.) and the lower thread guide plate.
2. Remove setscrew B, setscrews C (2 pcs.) and thread catcher panel.
3. Hook the tail of the check spring into the one of three slits.
Use a narrow screwdriver to hook the check spring.
 - Top slit: Higher tension
 - Center slit: Standard tension
 - Bottom slit: Lower tension
4. Attach the thread catcher panel and lower thread guide plate.

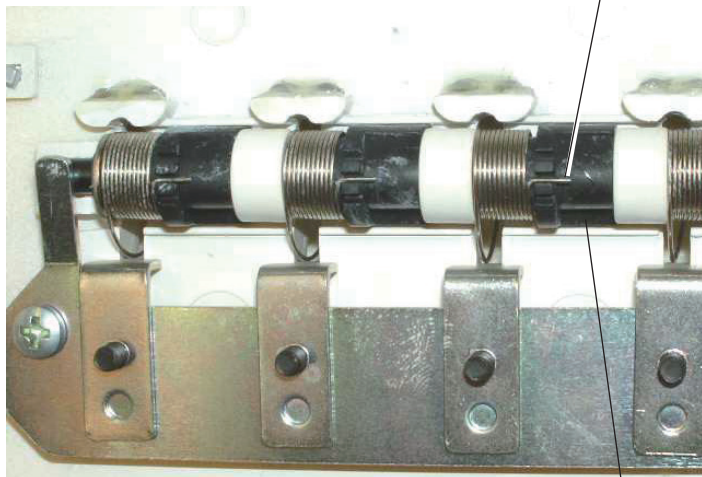

Check spring

Block

Adjusting the Check Spring Stroke

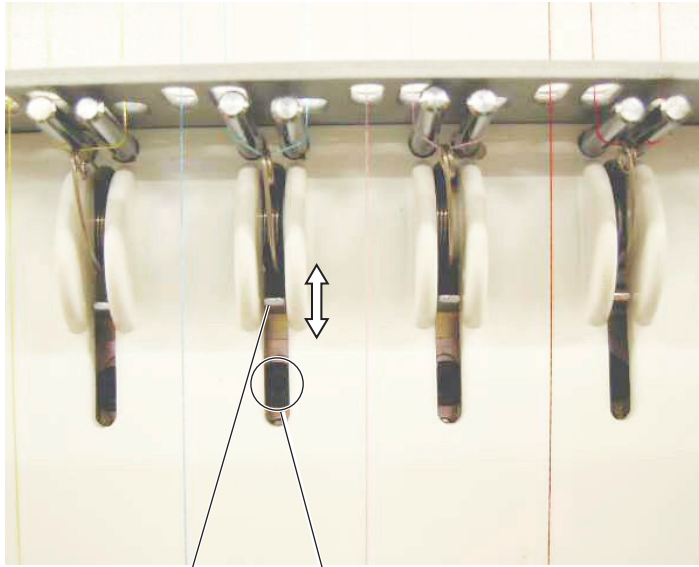

Adjustor

Setscrew

Check spring stroke is not necessary to adjust under normal conditions. However, you need to adjust the stroke of the check spring when it is replaced.

1. Loosen the setscrew. Move the adjuster up or down so the distance between the top of the check spring and the bottom side of the thread guide pin is 7 mm.

For a longer stroke, move the adjuster down.
For a shorter stroke, move the adjuster up.

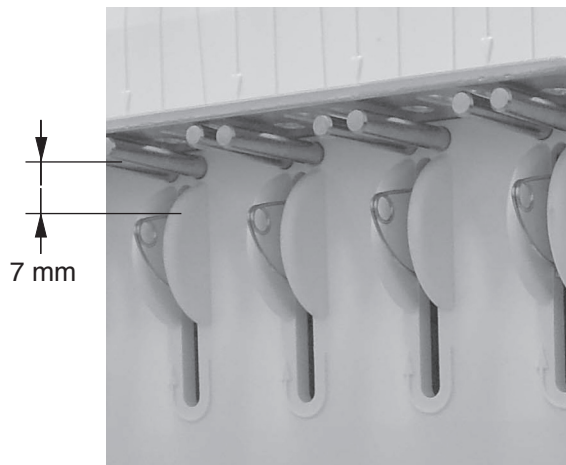

7 mm

Adjusting the Thread Catcher Holder

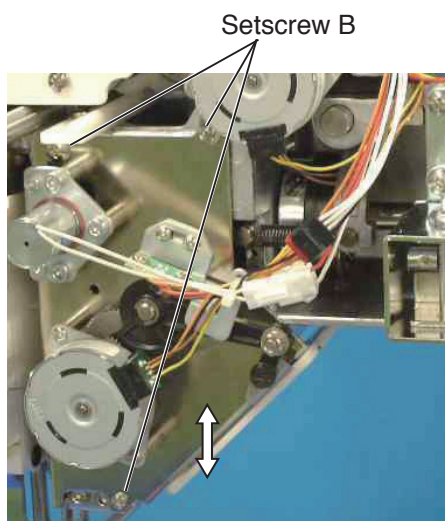
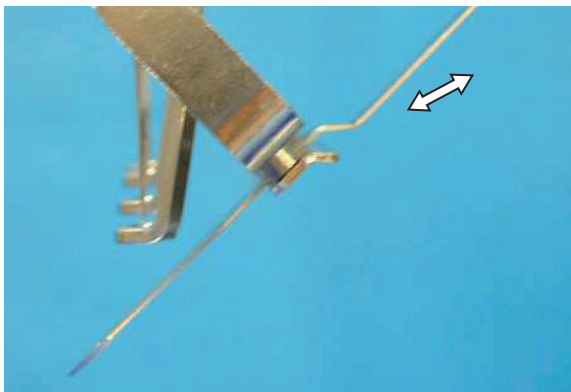
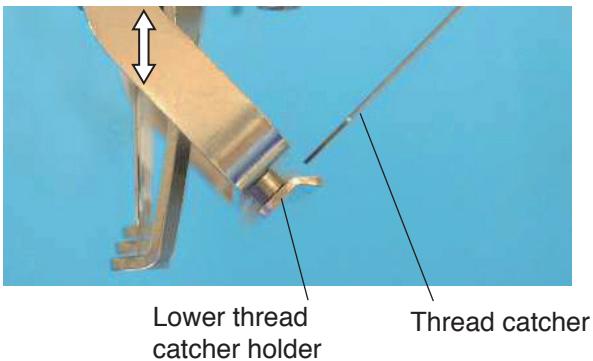
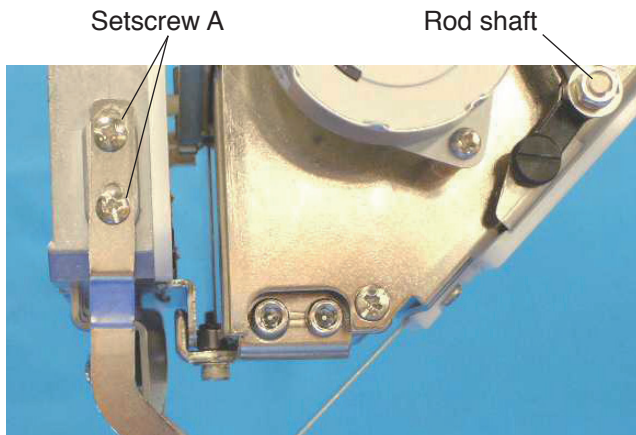

1. Remove the head set right cover (unit) (see page 5).
 2. Remove the thread catcher panel and lower thread guide plate (see pages 8).
 3. Loosen the setscrews A (4 pcs.).
 4. Pull the thread catcher out to set the tip of the thread catcher on the lower thread catcher holder. Move the thread catcher holder up or down so the lower surface of the thread catcher touches the upper surface of the lower thread catcher holder.
- NOTE:**
If an adjustment allowance of the thread catcher holder is not enough, loosen the setscrews B (3 pcs.) and move the thread catcher unit.
5. Check if the thread catcher moves smoothly by moving the rod shaft with your hand. Tighten the setscrews A (4 pcs.).
 6. Press the thread cutter button to test thread cutting and catching.
 7. Attach the parts removed in steps 1 and 2.

Replacing the Thread Catcher Loop Tape

1. Remove the head set right cover (unit) (see page 5).
2. Remove the thread catcher panel and lower thread guide plate (see pages 8).
3. Remove the setscrews A (4 pcs.) and remove the thread catcher holder unit.
4. Remove the setscrews B (2 pcs.) and remove the spacers (2 pcs.) (S) and the lower thread catcher holder.
5. Peel the loop tape off. Stick a new loop tape on the bottom side of the thread catcher holder, aligning with the front edge of the holder. Leave a 2 mm space from the threaded hole at each side.
6. Attach the spacers (S) (2 pcs.) and lower thread catcher holder with the setscrews B (2 pcs.).
7. Attach the parts removed in steps 1 and 2.

Setscrew A

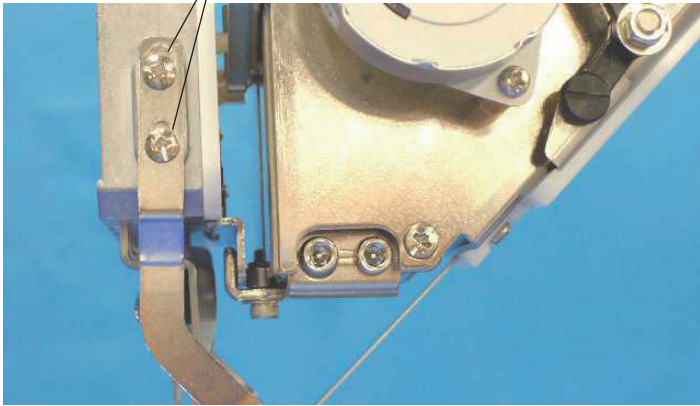

Spacers (S)

Setscrew B

Setscrew B

Lower thread catcher holder

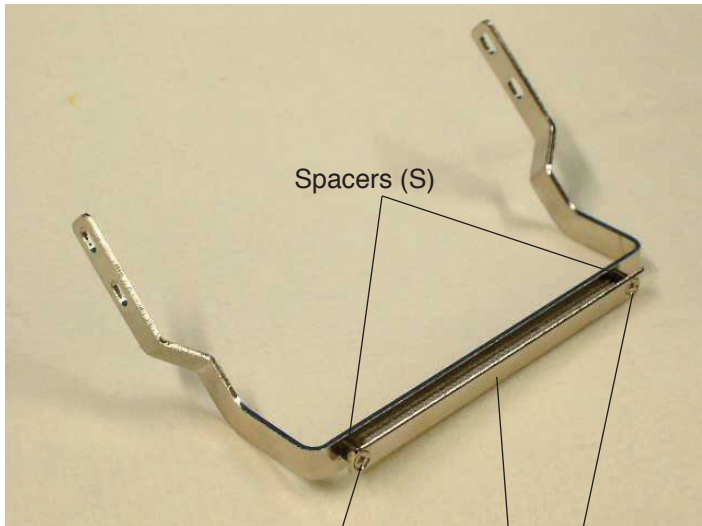

Upper thread catcher holder

2 mm

2 mm

Loop tape

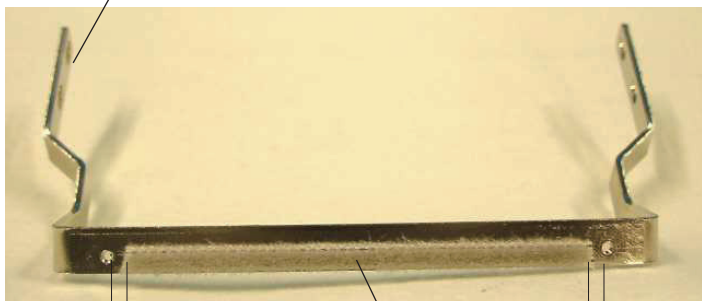

Replacing the Lateral Moving Unit

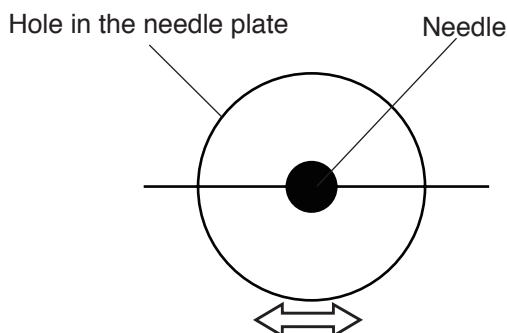
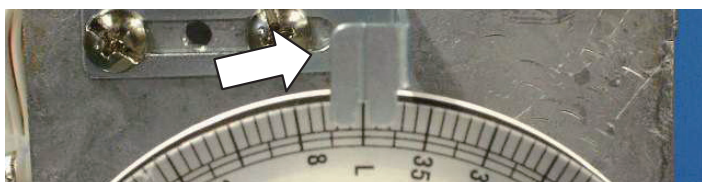
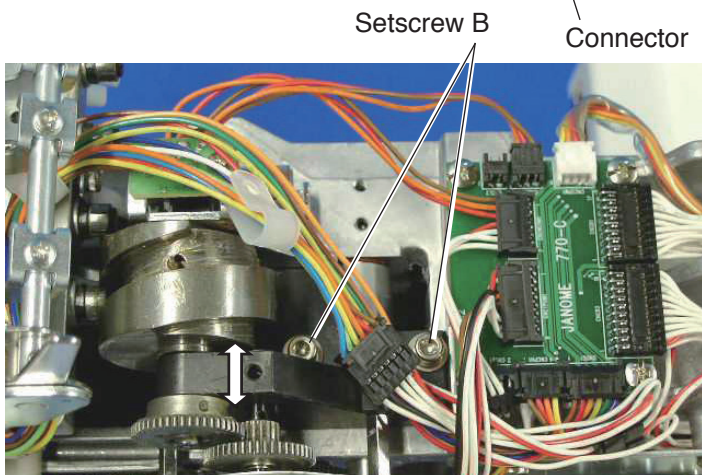
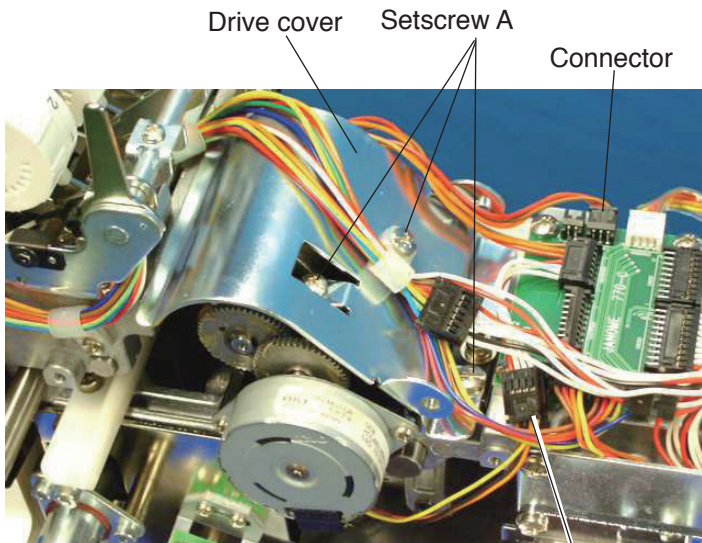

To remove:

1. Remove the spool stand, right cover and left cover (see pages 4 and 5).
2. Remove the thread tension panel (see page 4).
3. Remove the setscrews A (3 pcs.) and remove the driver cover.
4. Disconnect the connectors.
5. Remove the setscrews B (2 pcs.) and remove the lateral moving unit.

To attach:

6. Attach the lateral moving unit and partially fix it with the setscrews B (2 pcs.).
7. Push the needle bar down and rotate the handwheel to set the index disk at "L".
8. Adjust the position of the lateral moving unit so the needle enters into the center of the hole in the needle plate. Tighten the set screws B (2 pcs.) securely.
9. Connect the connectors and attach the parts removed in steps 1 to 3.

Adjusting the Hook Timing

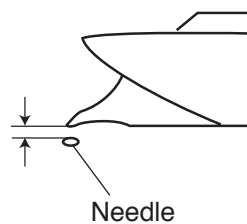
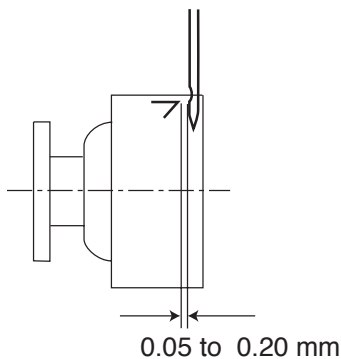
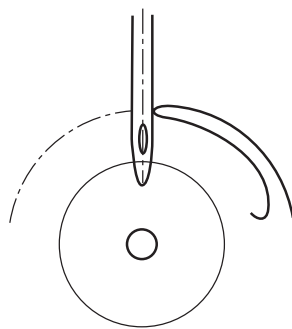
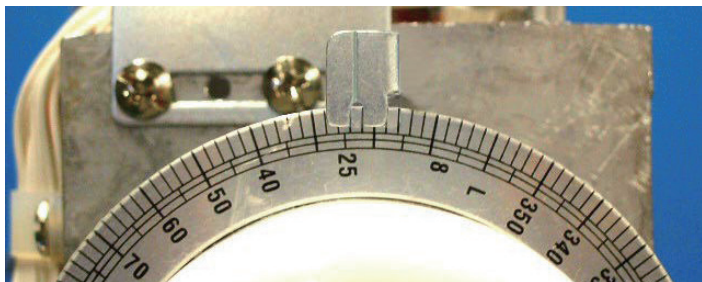
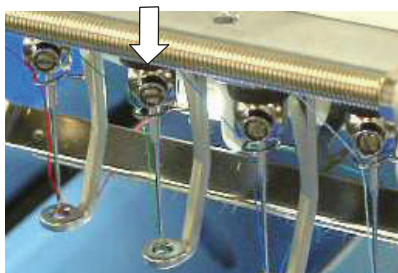
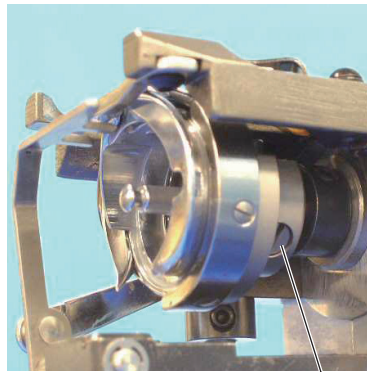
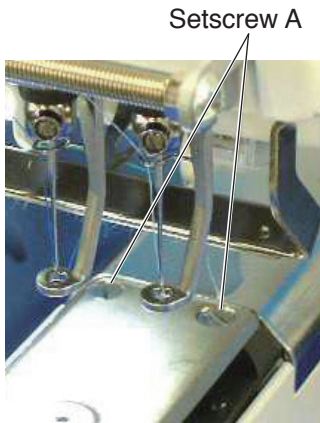

1. Remove the setscrews A (2pcs.) and needle plate.
2. Loosen the setscrews (3 pcs.) on the hook.
3. Select No. 3 needle bar in the Ready to Sew mode (see the instruction book) and push the needle bar down.
4. Turn the handwheel to set the index disk at 21°.

NOTE:

To prevent the needle from hitting the hook body, hold the hook with the hook point up while turning the handwheel.

5. Turn the hook to align the hook point with the right side of the needle (use DBxK5Q1NY needle).

NOTE:

Maintain a clearance between the needle and hook point within 0.05 to 0.20 mm.

6. Tighten the setscrews (3 pcs.) securely.
7. Check the position of the hook stopper (see page 42).

Adjusting the Position of the Hook Stopper

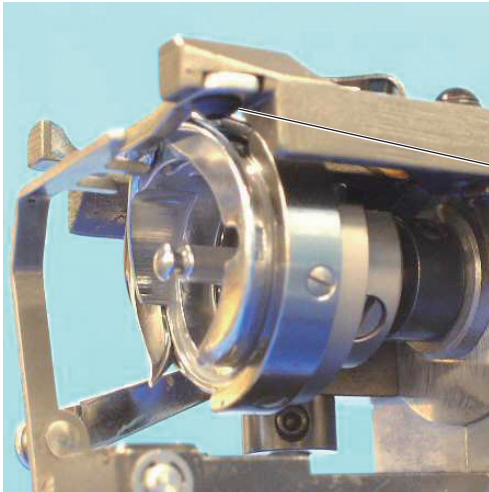

Setscrew

1. Loosen the setscrew to move the hook stopper.
2. Move the hook stopper to align the center with the needle and make a 0.6 to 0.8 mm clearance between the hook.
Tighten the setscrew securely.

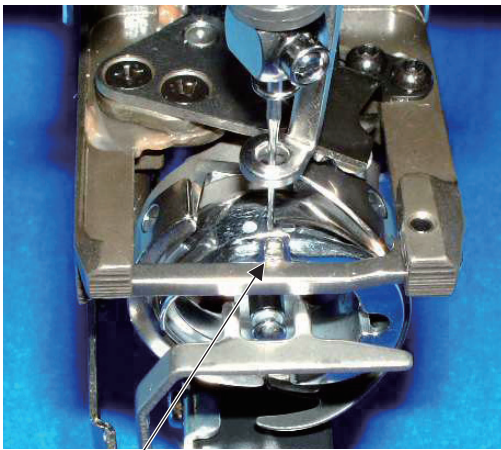

Align the center with the needle.

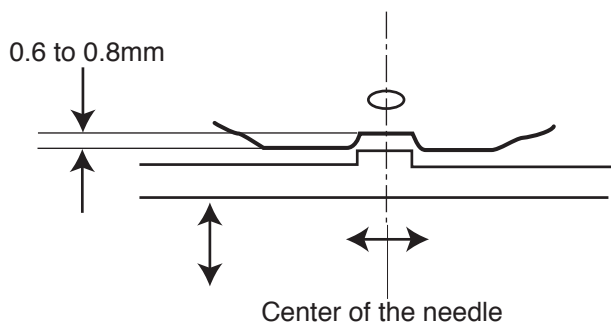

Replacing the Thread Cutter Driving Roller

1. Remove the spool stand and right cover (see pages 4 and 5).
2. Loosen the setscrew and remove the pivot pin. Remove the lever unit from the frame.

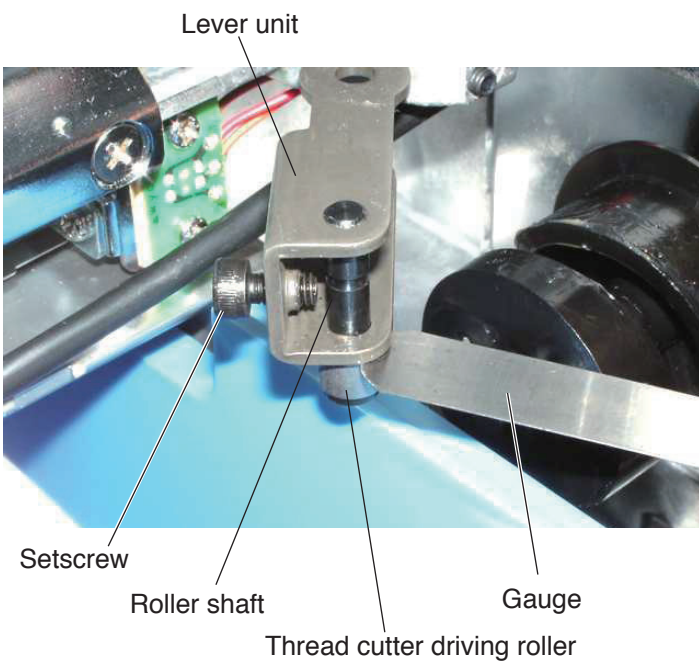

3. Loosen the setscrew and remove the roller shaft. Replace the thread cutter driving roller.
4. Insert the 0.05 mm thickness gauge between the lever unit and thread cutter driving roller. Tighten the setscrew securely.
5. Attach the lever unit to the frame and insert the pivot pin. Tighten the setscrew securely.
6. Adjust the position of the dynamic cutter blade (see page 45).
7. Attach the parts remove in step 1.

Replacing the Dynamic Cutter Blade

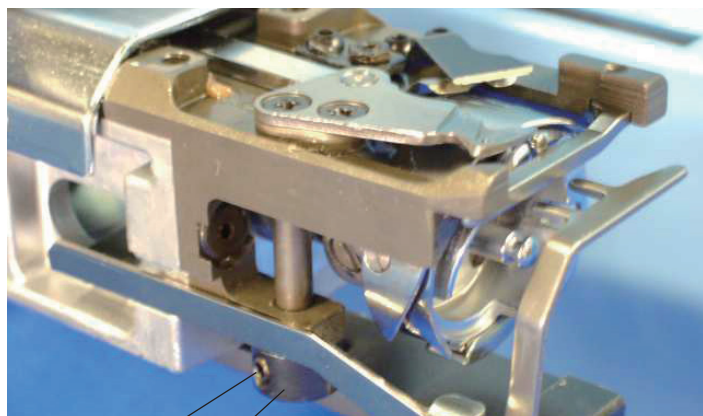
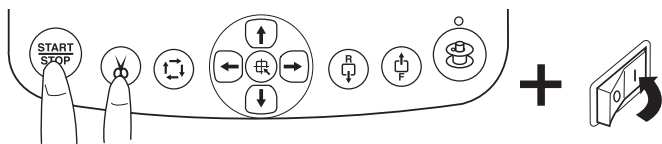

Setscrew B
Drive shaft ring

Dynamic cutter blade

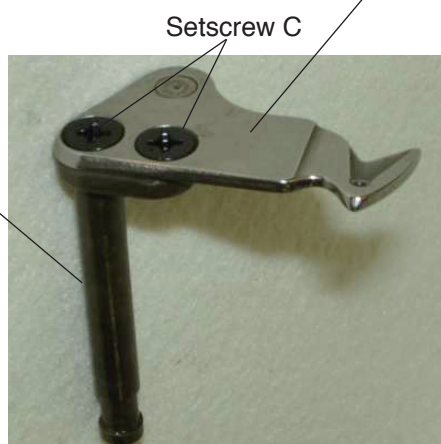

Drive shaft unit

Setscrew C

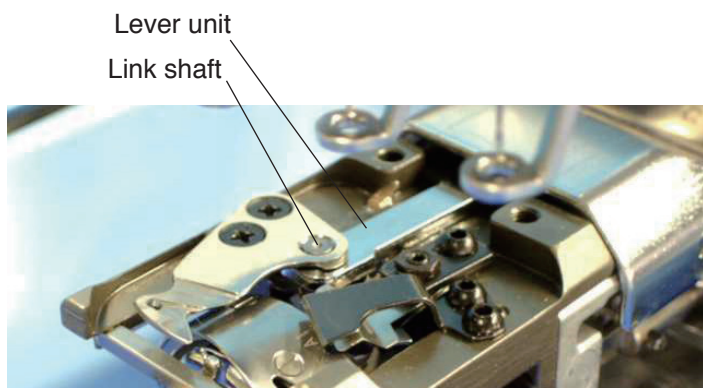

Lever unit

Link shaft

1. Remove the setscrews A (2 pcs.) and needle plate.
 2. Turn the power switch on while pressing the Start/ Stop button and Thread cutter button at the same time to open the **Factory Adjusting** window. Press the **Phase** key to open the **Phase Sensor** adjusting window and press the **All Int** key. Press the **Cancel** key to return to the previous window. Press the **Cut Adjust** key to open the **Cut Motor** adjusting window. Press **Divide** key to move the dynamic cutter blade forward.
 3. Loosen the setscrew B and remove the drive shaft ring.
 4. Remove the cutter drive shaft unit from the frame. Remove the setscrews C (2 pcs.) and replace the dynamic cutter blade.
 5. Insert the drive shaft into the frame and link pin of the cutter drive shaft unit into the hole in the lever unit.
 6. Attach the drive shaft ring and tighten the setscrew while pressing the ring and shaft unit each other with your fingers.
- NOTE:**
Be sure that there is no thrust play in the shaft unit.
7. Adjust the cutter blades position (see following pages) and test auto thread cutting.
 8. Attach the needle plate with the setscrews A.

Replacing the Static Cutter Blade

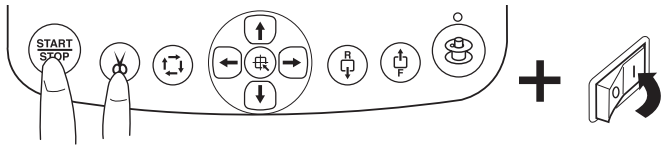

Setscrew A



Static cutter blade

Setscrew B

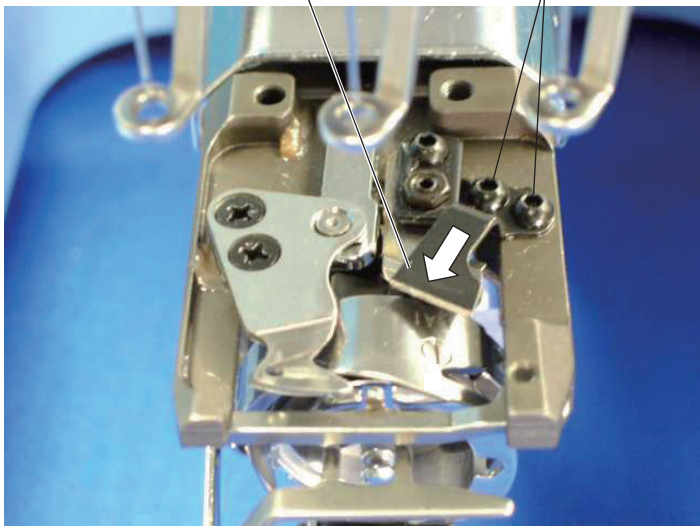

1. Remove the setscrews A and needle plate.
2. Turn the power switch on while pressing the Start/ Stop button and Thread cutter button at the same time to open the **Factory Adjusting** window. Press the **Cut Adjust** key to open the **Cut Motor** adjusting window. Press **Divide** key to move the dynamic cutter blade forward.
3. Remove the setscrews B (2 pcs.) and replace the static cutter blade.
4. Attach the static cutter blade and tighten the setscrews while pressing the static cutter blade in the direction of the arrow.

NOTE:

If the dynamic cutter blade interferes with the left corner of the static cutter blade when moving the dynamic cutter blade, shift the static cutter blade to the right.

5. Adjust the cutter blades position (see following pages) and test auto thread cutting.
6. Attach the needle plate with the setscrews A (2pcs.).

Adjusting the Static Cutter Blade

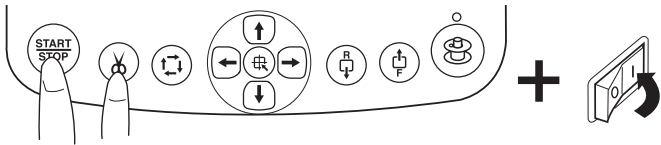

Setscrew A

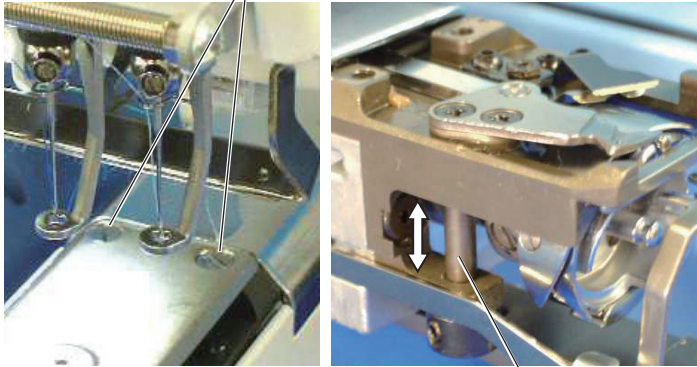

Cutter drive shaft

Upper adjusting screw

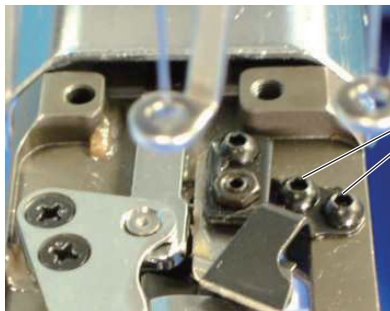

Nut

Lower adjusting screw

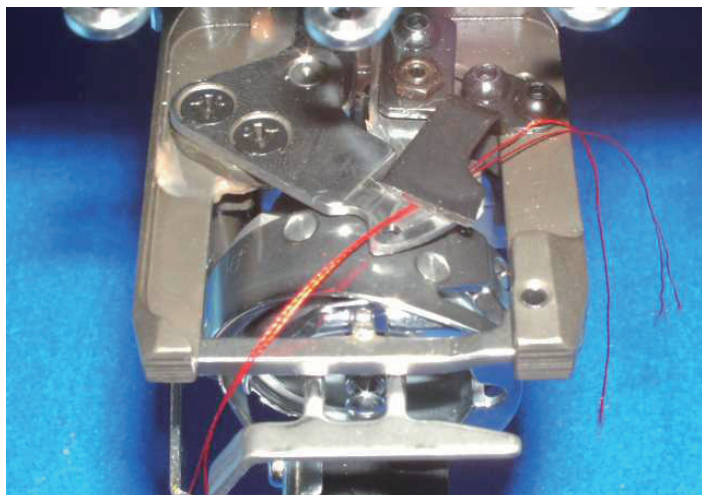

1. Remove the setscrews A (2pcs.) and needle plate.
2. Turn the power switch on while pressing the Start/ Stop button and Thread cutter button at the same time to open the **Factory Adjusting** window. Press the **Cut Adjust** key to open the **Cut Motor** adjusting window. Press **Init** key to move the dynamic cutter blade to the home position.
3. Check if there is no play in the cutter drive shaft and eliminate a play if any.
4. The front tip of the dynamic cutter blade should extends 0.3 to 0.5 mm from the edge of the static cutter blade.
If there is a gap between the edge of the static cutter blade and the dynamic cutter blade, adjust the height of the static cutter blade.
Loosen slightly the setscrews (2 pcs.) and nut on the adjusting screw. Screw in the adjusting screw until the edge of the static cutter blade evenly touches the upper surface of the dynamic cutter blade.
Tighten the setscrews (2 pcs.) and nut.
5. Test auto thread cutting with polyester threads size #120 both in the needle and bobbin.
6. Attach the needle plate with the setscrews A (2pcs.).

Adjusting the Dynamic Cutter Blade

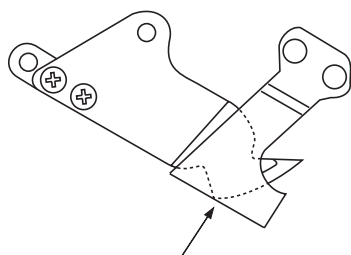
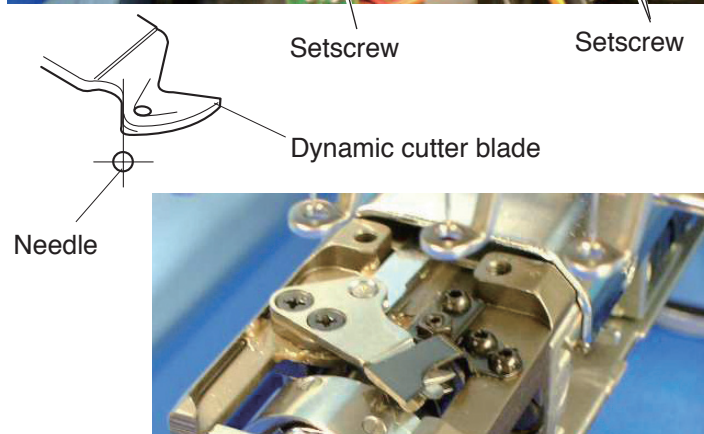
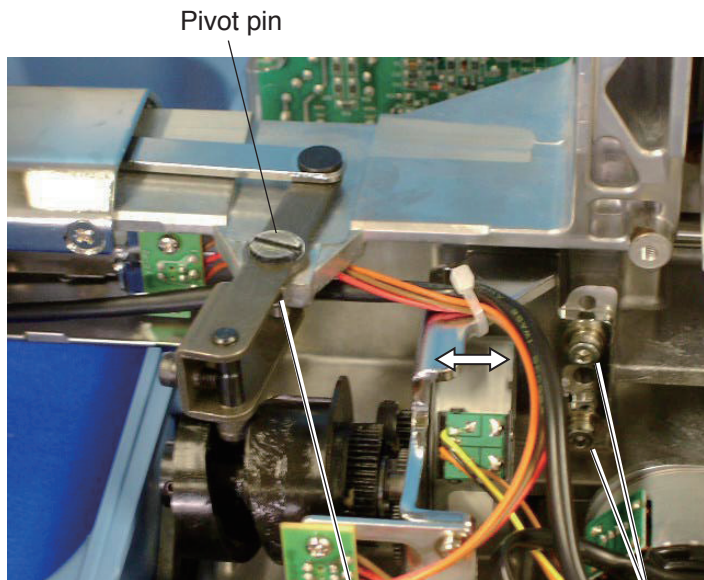
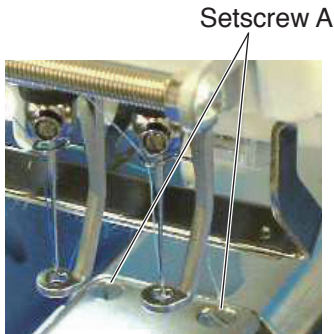
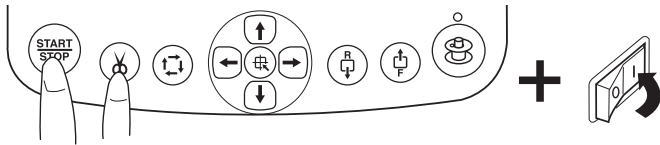

Align the point of the dynamic cutter blade with the edge of the static cutter blade.

1. Remove the spool stand, head set right cover and left cover (see pages 4 to 6).
2. Remove the setscrews A (2 pcs.) and needle plate.
3. Turn the power switch on while pressing the Start/ Stop button and Thread cutter button at the same time to open the **Factory Adjusting** window. Press the **Cut Adjust** key to open the **Cut Motor** adjusting window. Press **Init** key to move the dynamic cutter blade to the home position.
4. Loosen the setscrew and turn the pivot pin to adjust the position of the dynamic cutter blade so the front tip of the dynamic cutter blade is in line with the center of the needle drop position.

NOTE:

If an adjustable allowance is not enough, loosen the setscrews (2 pcs.) and move the thread cutter drive unit in the direction of the arrow.

5. Test auto thread cutting with polyester threads size #120 both in the needle and bobbin.
6. Attach the needle plate with the setscrews A (2pcs.).
7. Attach the parts removed in step 1.

Adjusting the Bobbin Thread Holder

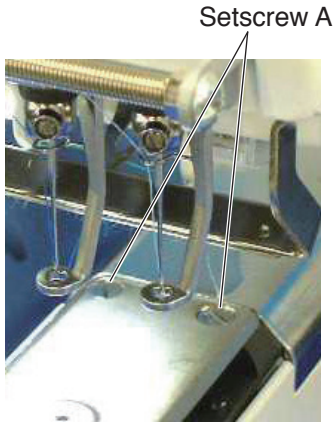

1. Remove the setscrews A (2pcs.) and needle plate.
2. Place the bobbin thread between the dynamic cutter blade and bobbin thread holder. Close the dynamic cutter blade to clamp the bobbin thread.
3. Loosen the nut and turn the adjusting screw to adjust the clamping pressure.
4. Pull the bobbin thread with a tension gauge and read the tension when the bobbin thread is coming out. The tension should be 20 to 30 grams-force. Check the tension several times.
5. Tighten the nut while holding the adjusting screw in place.
6. Attach the needle plate with the setscrews A (2pcs.).

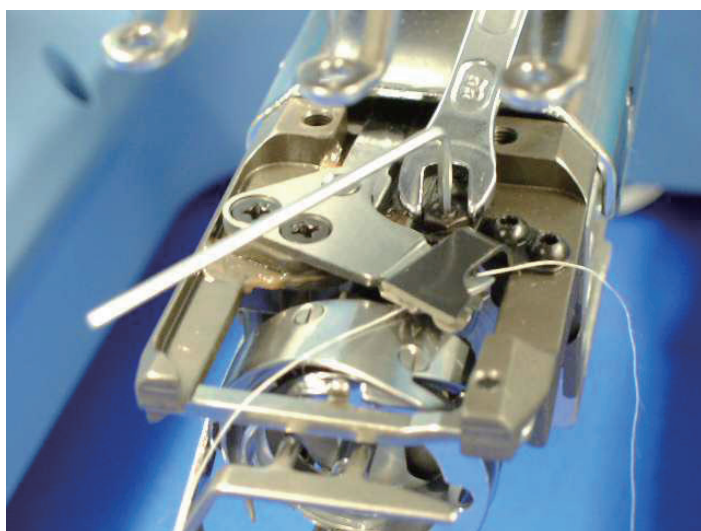
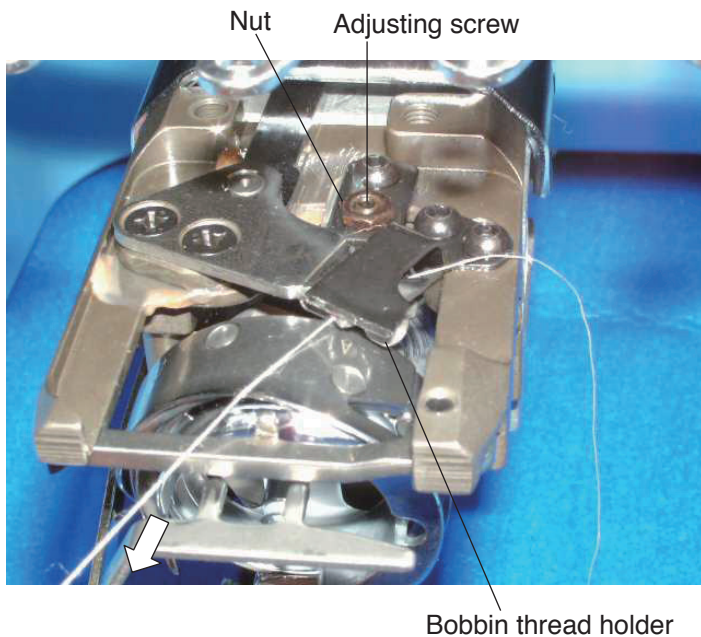

Adjusting the Thread Keeper

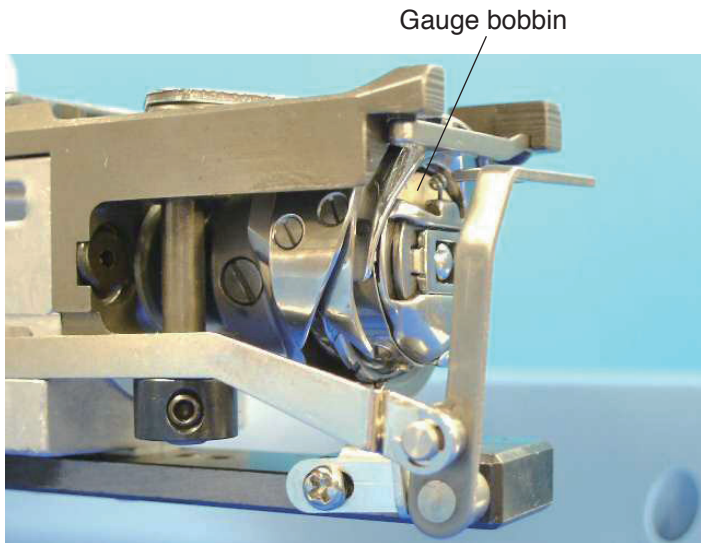

1. Insert the gauge bobbin (a 1.6 mm thick spacer stuck on it) into the bobbin case and insert the bobbin case into the hook.
2. Loosen the setscrews A (2 pcs.) and insert a 2 mm thick gauge between the frame of the solenoid and washer on the plunger.
3. Slide the solenoid in the direction of the arrow until the tips of the thread keeper touch the 1.6 mm spacer on the bobbin.
Tighten the setscrews A (2 pcs.) securely.

NOTE:

The clearance between the bobbin and the tips of the thread keeper should be 1.4 to 1.8 mm.

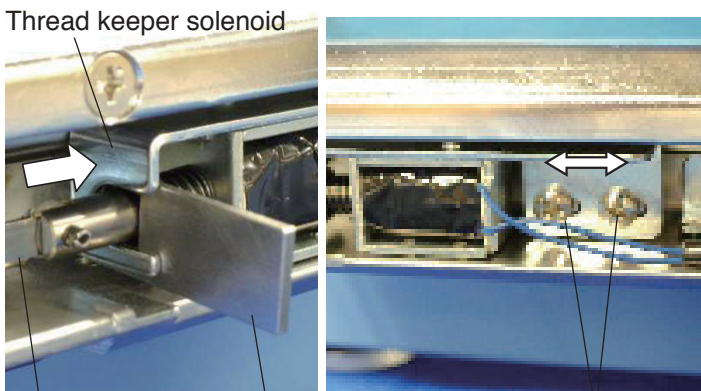

Thread keeper solenoid
Thread keeper rod
2 mm thick gauge
Setscrew A

4. Loosen the setscrew B and move and press the stopper against the thread keeper rod.
Remove the 2 mm thick gauge and push the thread keeper toward the bobbin to check if the tips of the thread keeper touches the 1.6 mm thick spacer on the bobbin.
5. Tighten the setscrew B securely.
6. Attach the needle plate.

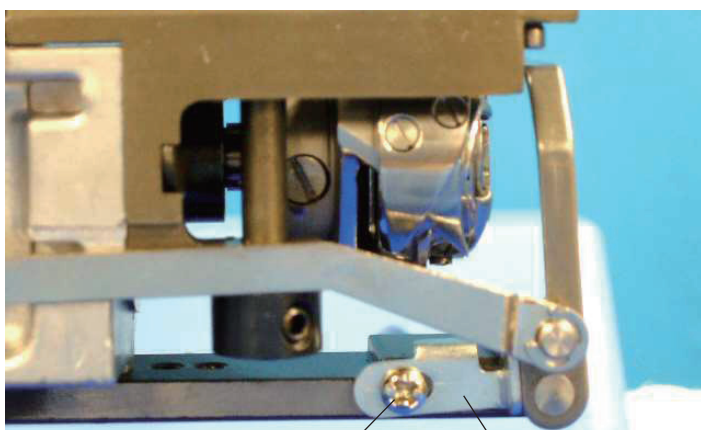
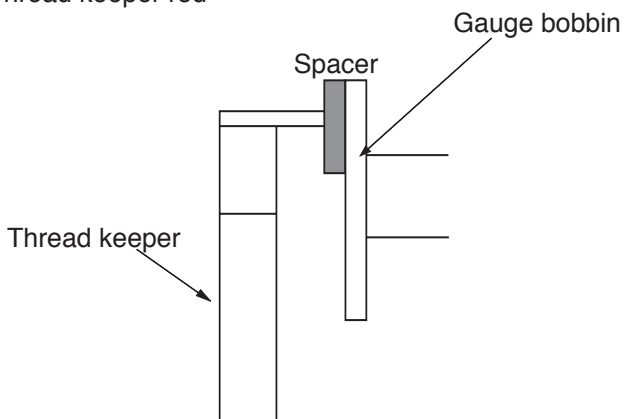

Setscrew B
Stopper

Adjusting the X-carriage Belt Tension

1. Remove the spool stand, head set right cover and left cover (see pages 4 to 6).
2. Loosen the setscrews A (2 pcs.) and remove the X-carriage cover.
3. Shift the hoop supporter to the extreme left end. Set the push-pull gauge at the right side of the machine frame and push the X-carriage timing belt. The gauge should read 600 grams when the upper portion touches the lower portion.
4. If the belt tension is too tight or loose, slightly loosen the setscrews B (2 pcs.) and move the X-belt pulley in the direction of the arrow to adjust the belt tension. Tighten the tow setscrews B securely and check the tension again.

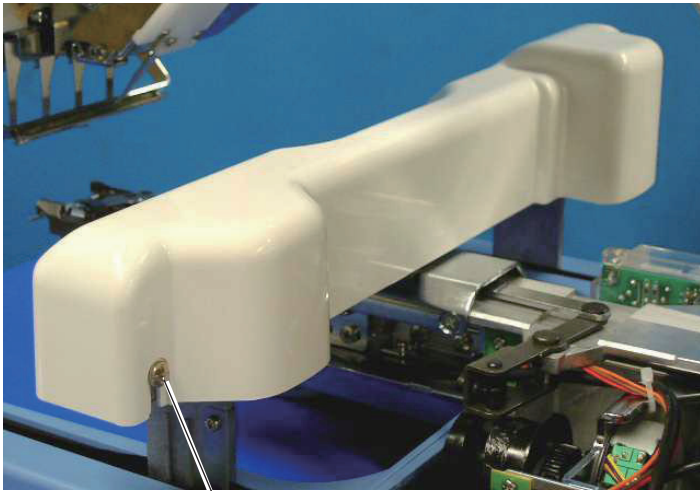

Setscrew A

Push-pull gauge

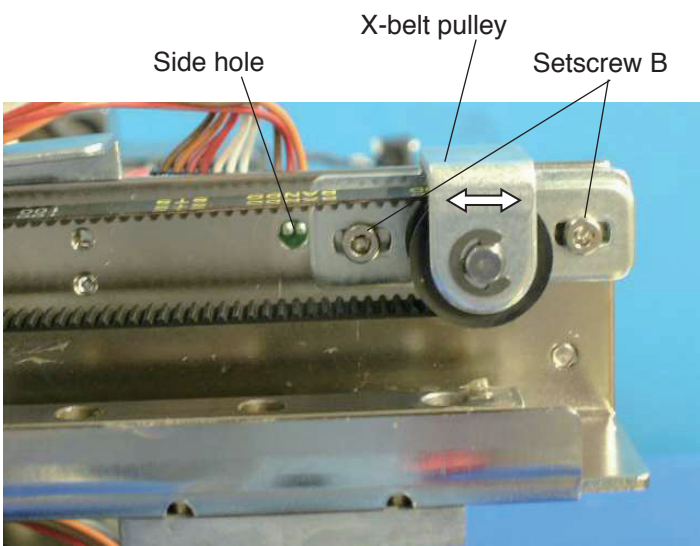
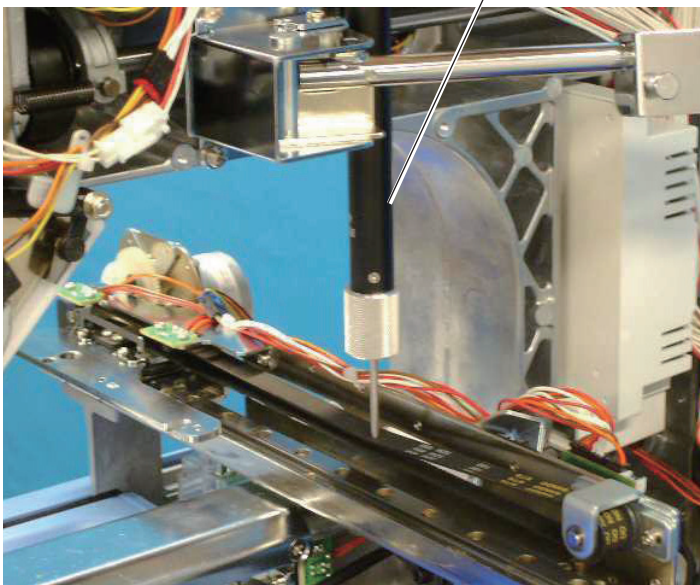

NOTE:
When moving the X-belt pulley, insert a 4 mm rod into the side hole and pry the base plate of the pulley.

5. Attach the X-carriage cover with the setscrews A (2 pcs.).
6. Attach the parts removed in step 1.

Replacing the X-carriage Belt

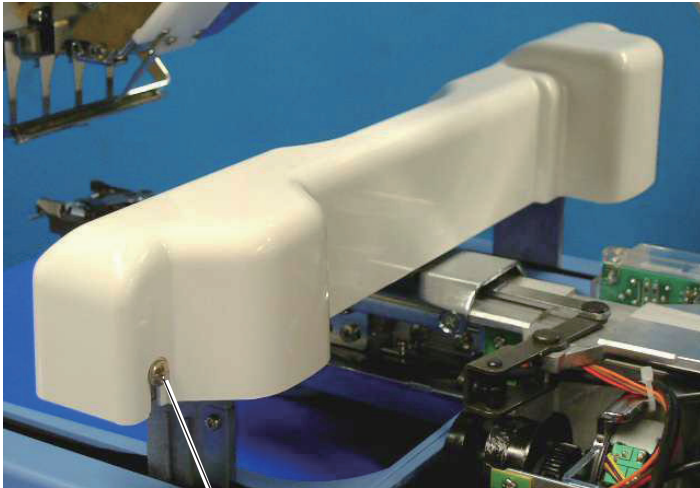

Setscrew A

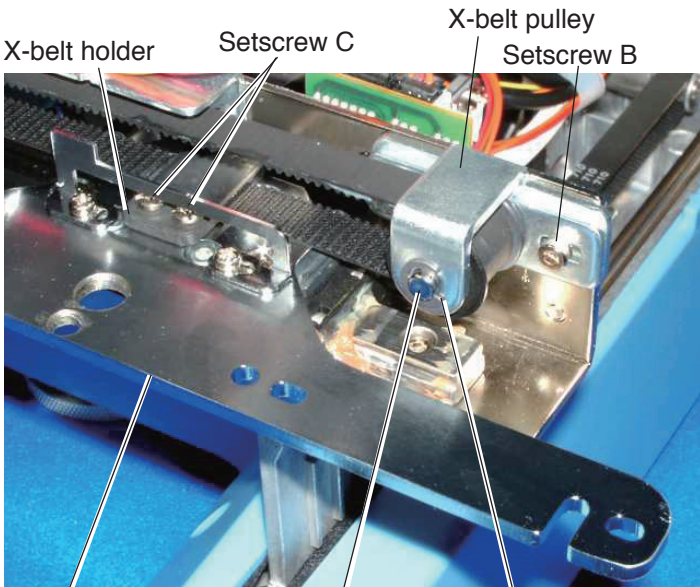

X-belt holder

Setscrew C

X-belt pulley

Setscrew B

Hoop supporter

X-belt pulley shaft

E-ring

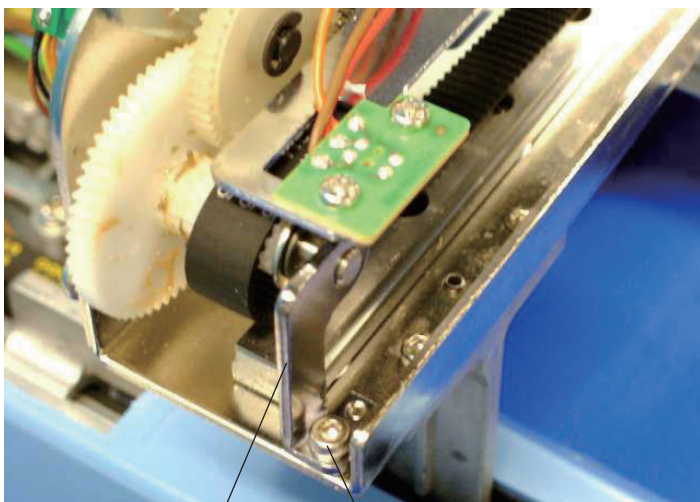

Drive pulley shaft unit

Setscrew D

1. Remove the spool stand, head set right cover and left cover (see pages 4 to 6).
2. Loosen the setscrews A (2 pcs.) and remove the X-carriage cover.
3. Shift the hoop supporter to the extreme left end. Remove the setscrews C (2 pcs.) and the X-belt holder.
4. Loosen the setscrews B (2 pcs.) and shift the X-belt pulley in the direction of the arrow.
5. Remove the E-ring and pull the X-belt pulley shaft to remove the X-belt pulley.
6. Remove the setscrews D (2 pcs.) and drive pulley shaft unit.
7. Replace the X-carriage belt.
8. Attach the parts removed in steps 3 to 6.
9. Adjust the X-carriage belt tension (see the previous page).
10. Attach the parts removed in steps 1 to 2.

Adjusting the Y-carriage Belt Tension

1. Remove the spool stand, head set right cover and left cover (see pages 4 to 6).
2. Shift the X-carriage to the extreme front end.
3. Shift the X-carriage to the extreme front end. Set the push-pull gauge in line with the front end of the base frame and push the Y-carriage timing belt. The gauge should read 280 grams when the upper portion touches the lower portion.
4. If the belt tension is too tight or loose, slightly loosen the setscrews A (2 pcs.) and move the Y-belt pulley in the direction of the arrow to adjust the belt tension. Tighten the two setscrews A securely and check the tension again.
5. Attach the parts removed in step 1.

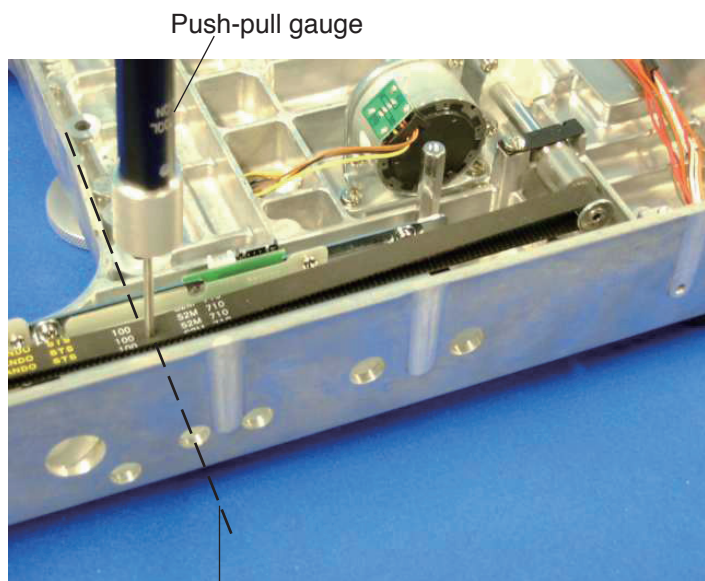

Front end of the base frame

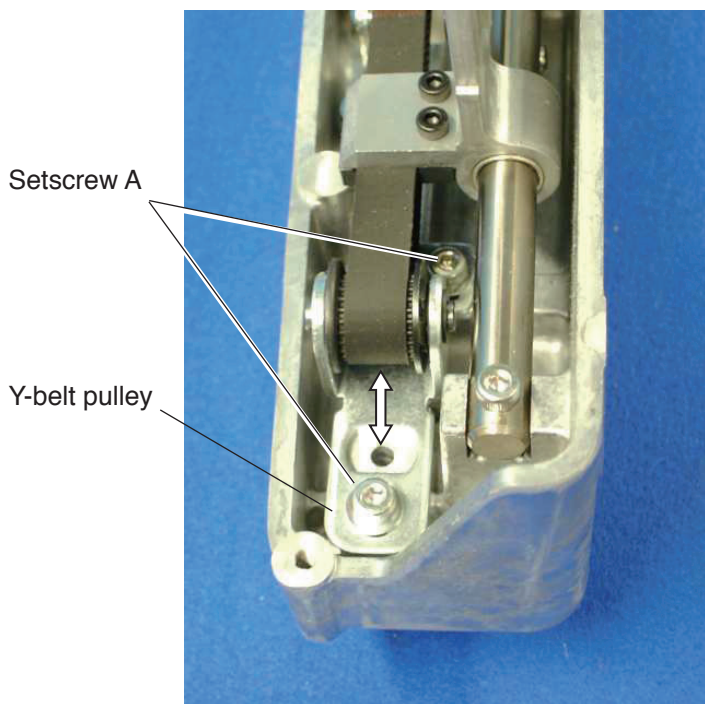

Replacing the Y-carriage Belt

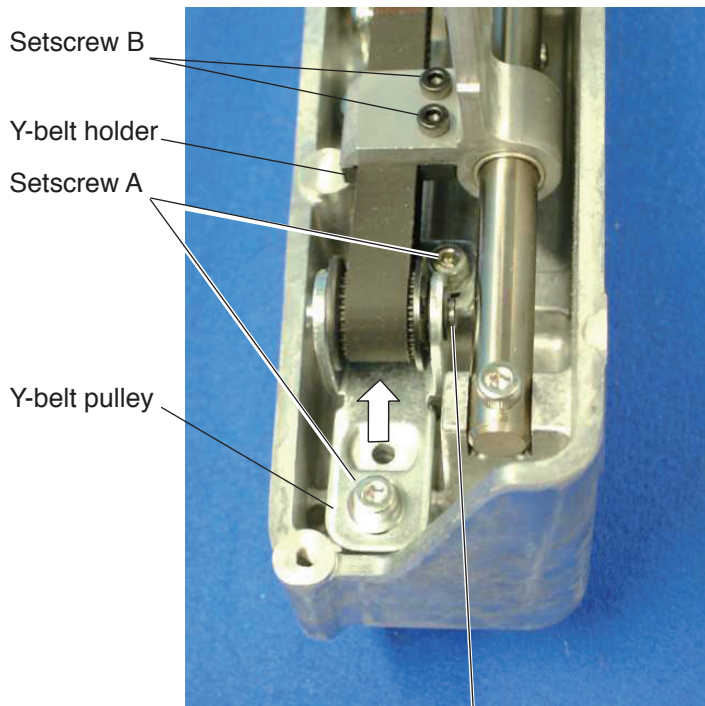

E-ring
Y-belt pulley shaft

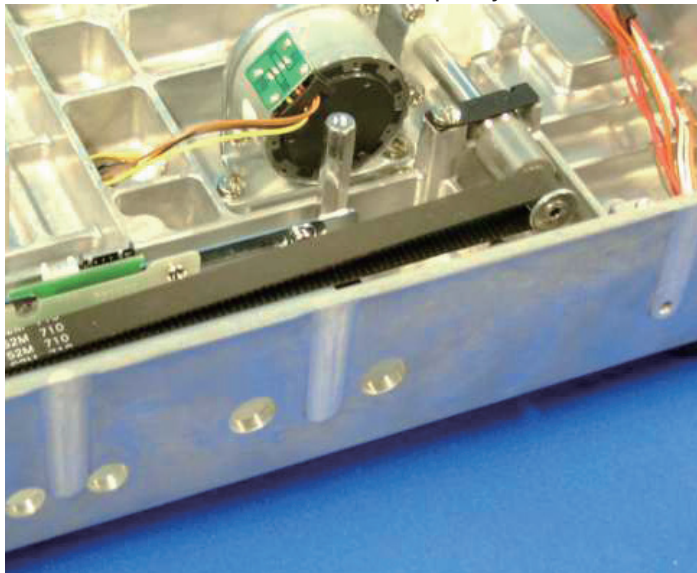

1. Remove the spool stand, head set right cover and left cover (see pages 4 to 6).
2. Remove the setscrews B (2 pcs.) and the Y-belt holder.
3. Loosen the setscrews A (2 pcs.) and shift the Y-belt pulley in the direction of the arrow.
4. Remove the E-ring and pull the Y-belt pulley shaft to remove the Y-belt pulley.
5. Replace the Y-carriage belt.
6. Attach the parts removed in steps 2 to 5.
7. Adjust the Y-carriage belt tension (see the previous page).
8. Attach the parts removed in step 1.

Adjusting the Timing Belt Tension

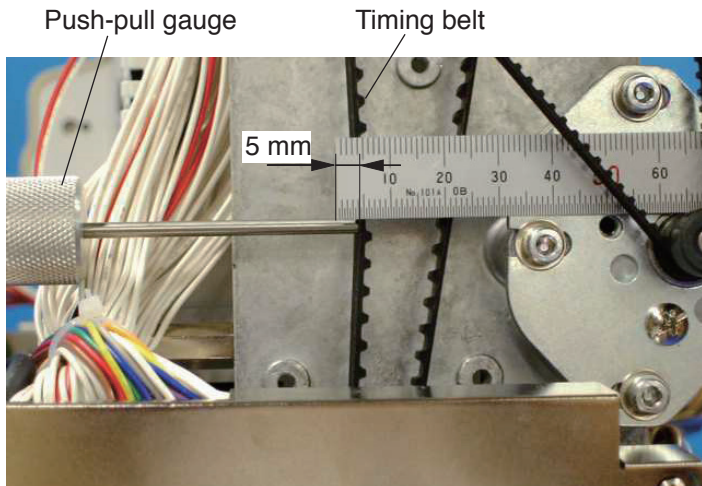

1. Remove the spool stand, head set right cover and left cover (see pages 4 to 6).
2. Place a scale on the DC motor. Set the push-pull gauge in line with the scale as illustrated and push the timing belt. The gauge should read 300 grams when the belt deflect 5 mm.
3. If the belt tension is too tight or loose, remove the setscrews A (3 pcs.) and Shielding case B, then slightly loosen the setscrews B (2 pcs.) and move the idler in the direction of the arrow to adjust the belt tension. Tighten the tow setscrews B securely and check the tension again.
4. Attach the parts removed in step 1.

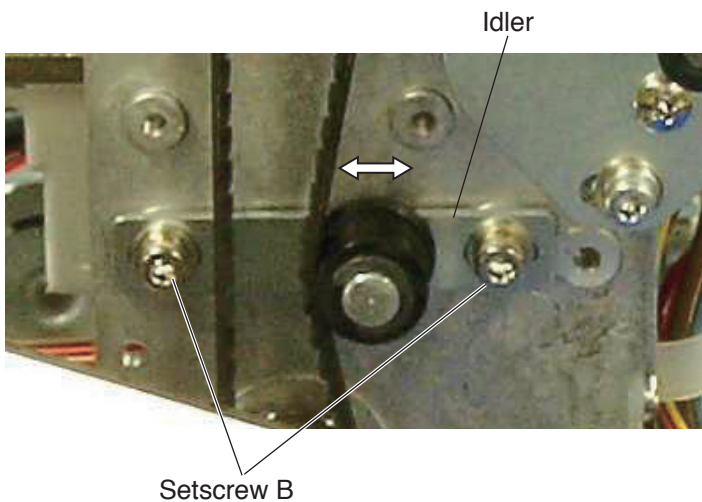
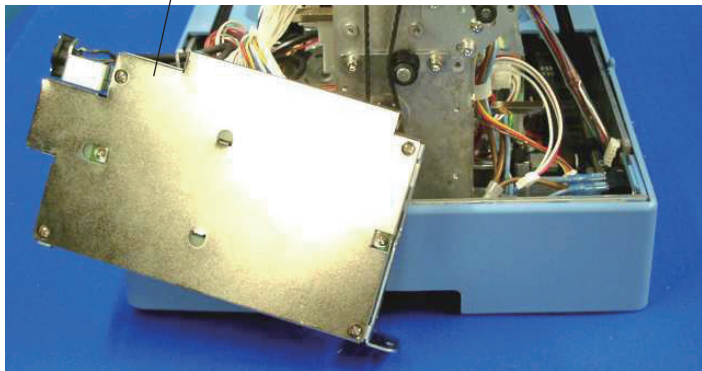
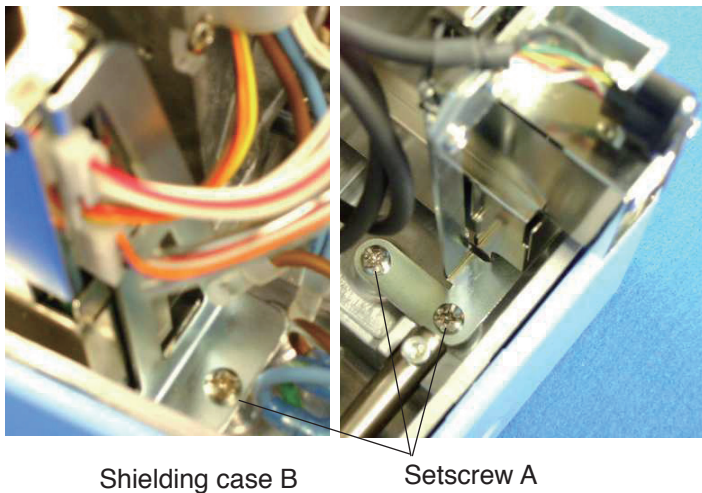

Replacing the Timing Belt

1. Remove the spool stand, head set right cover and left cover (see pages 4 to 6).
2. Remove the setscrews A (2 pcs.) and the pointer.
3. Remove the setscrews B (3 pcs.) and Shielding case B.
4. Remove the motor belt (see page 57).
5. Loosen the setscrews C (2 pcs.) and remove the idler.
6. Replace the timing belt.
7. Attach the parts removed in steps and 5.
8. Adjust the timing belt tension (see the previous page).
9. Check the following items and adjust them if necessary.
 - Needle bar lowest position
 - Hook timing
 - Thread cutter timing
10. Attach the parts removed in steps 1 to 3.

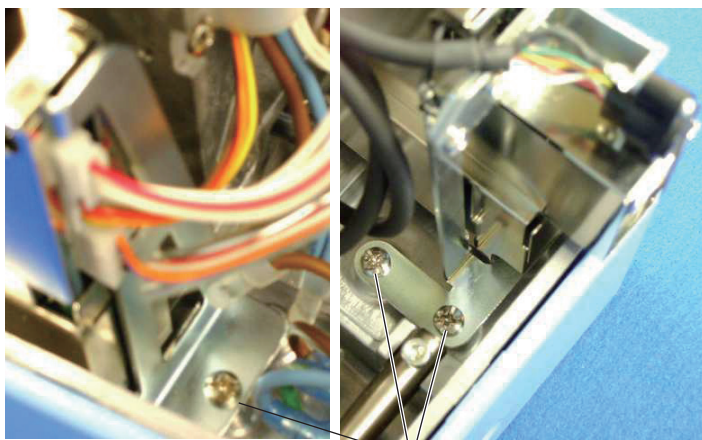
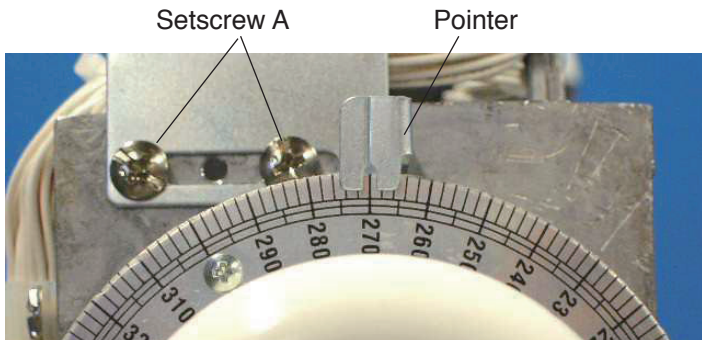

Shielding case B Setscrew B

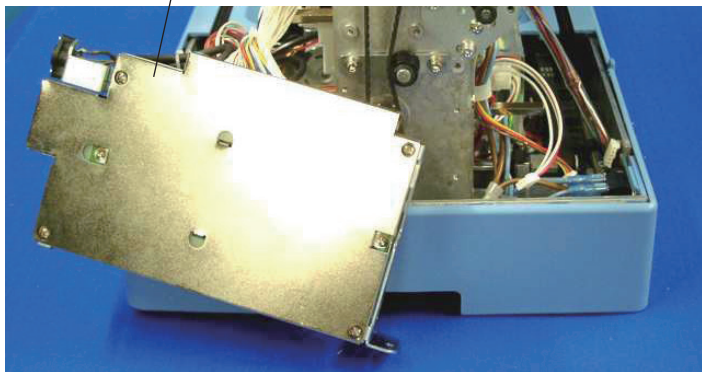

Timing belt Idler

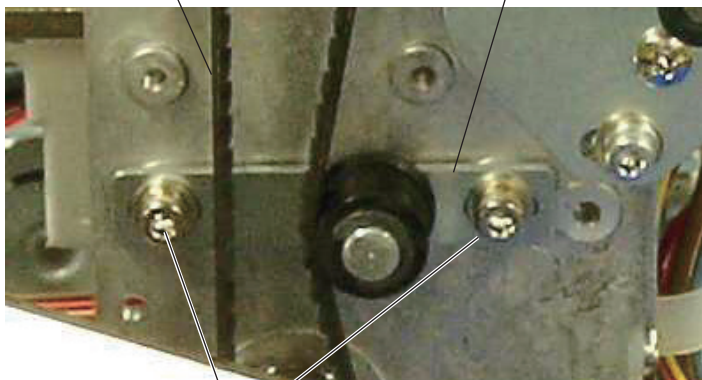

Setscrew C

Adjusting the Motor Belt Tension

1. Remove the spool stand, head set right cover and left cover (see pages 4 to 6).
2. Place a scale under the stud bolt. Set the push-pull gauge in line with the scale as illustrated and push the timing belt. The gauge should read 300 grams when the belt deflect 3 mm.
3. If the belt tension is too tight or loose, slightly loosen setscrews (3 pcs.) and move the motor in the direction of the arrow to adjust the belt tension. Tighten the setscrews (3 pcs.) securely and check the tension again.
4. Attach the parts removed in step 1.

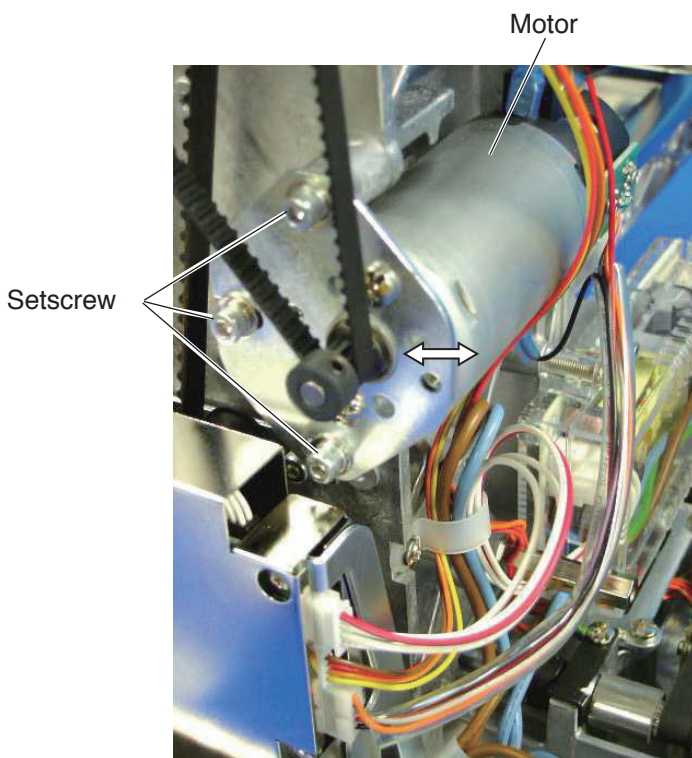
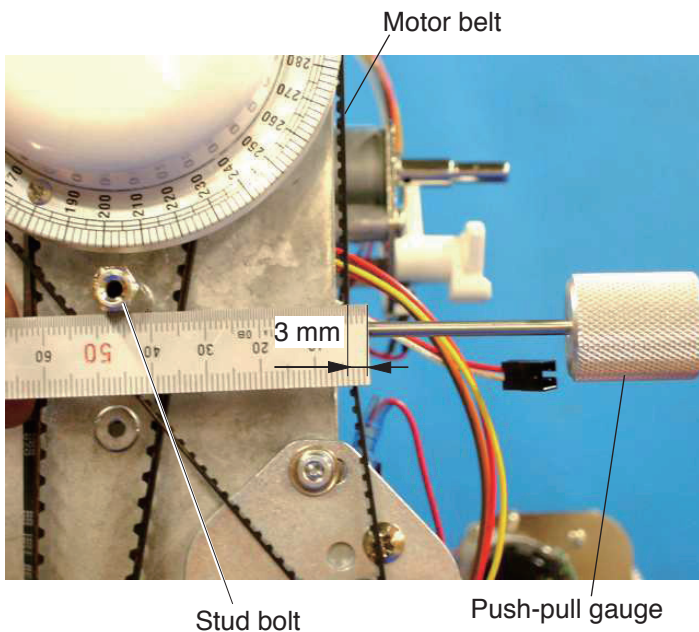

Replacing the Motor Belt

1. Remove the spool stand, head set right cover and left cover (see pages 4 to 6).
2. Remove the setscrews A (2 pcs.) and the pointer.
3. Remove the setscrews B (3 pcs.) and DC motor.
4. Replace the motor belt. Attach the motor and motor belt.
5. Adjust the motor belt tension (see the previous page).
6. Attach the parts removed in step 1.

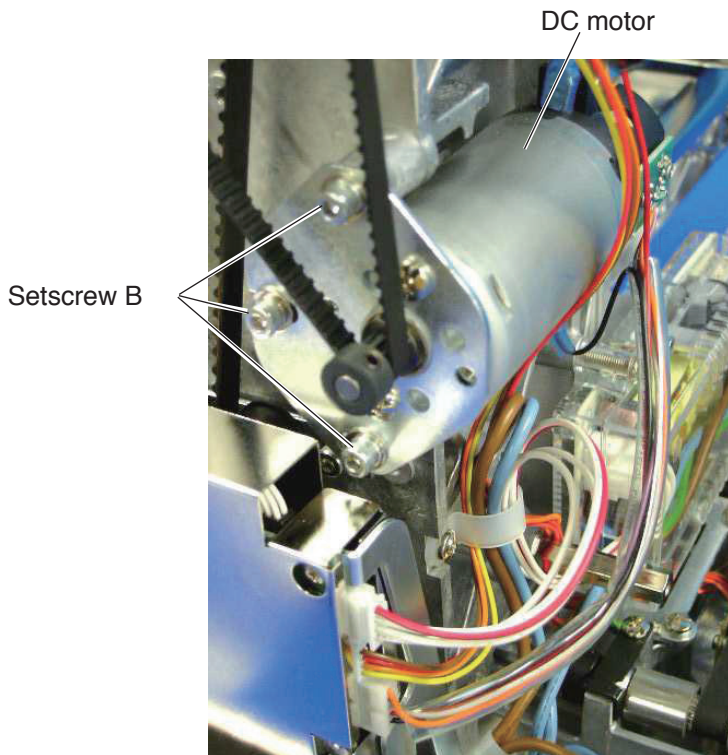
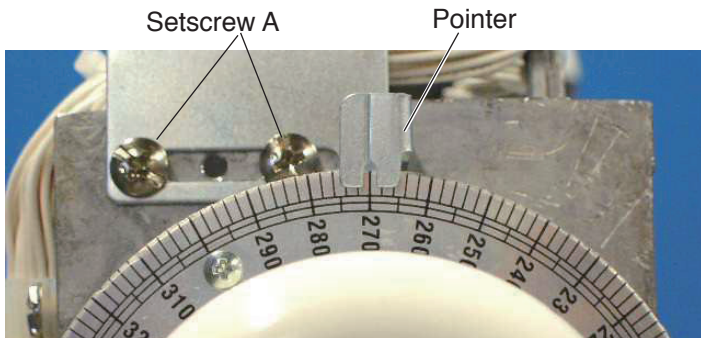

Replacing the DC Motor

1. Remove the spool stand, head set right cover and left cover (see pages 4 to 6).
2. Disconnect the motor connector. Remove the three setscrews A and DC motor.
3. Attach the DC motor and tighten the setscrews A (3 pcs.) slightly. Connect the motor connector.
4. Adjust the motor belt tension (see page 56).
5. Attach the parts removed in step 1.

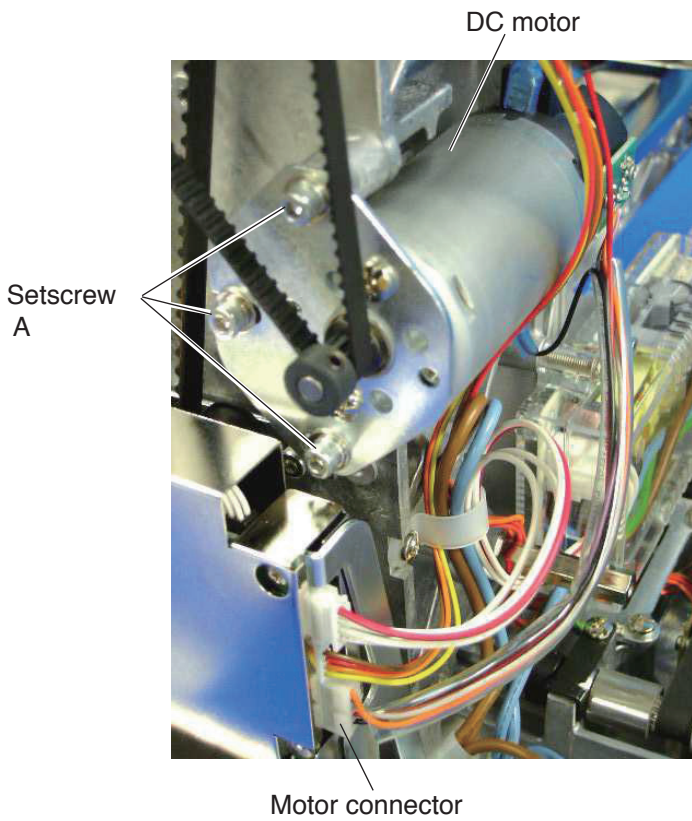

To Reset Motor Drive Time

A warning message will appear when the motor drive time has exceeded 1,000 hours.

- * The warning will be displayed until the motor is replaced and the motor drive time clock reset.

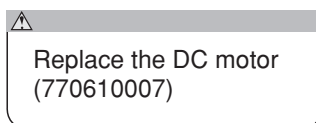

Replacing the DC Motor (770610007)

1. Remove the spool stand, static head right cover, right cover and left cover.
2. Disconnect the motor connector. Remove the 3 setscrews (A) and the motor.
3. Attach the DC motor and tighten the 3 setscrews (A) slightly. Connect the motor connector.
4. Adjust the motor belt tension.
5. Attach the parts removed in step 1.

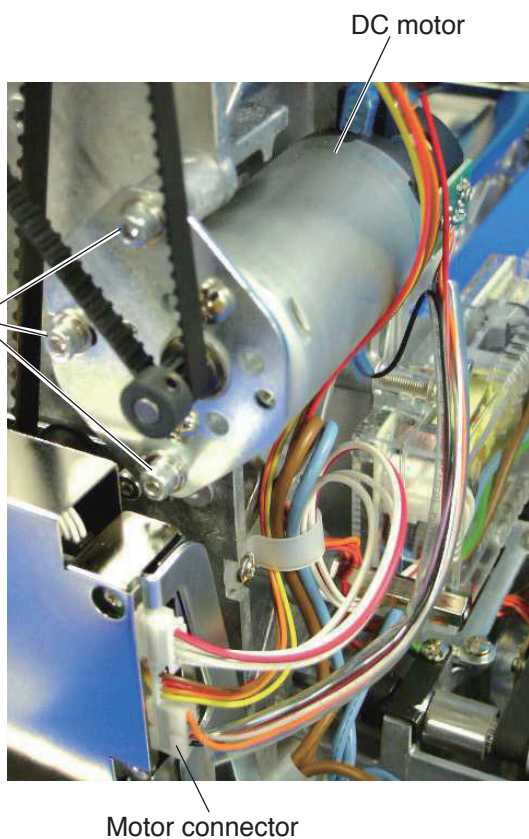

To reset motor drive time

1. After DC motor replacement, turn the power switch "ON" while pressing the needle forward button and the bobbin winding button
2. Press the "CLEAR" key to reset the motor drive time clock.
3. Turn the power switch "OFF".

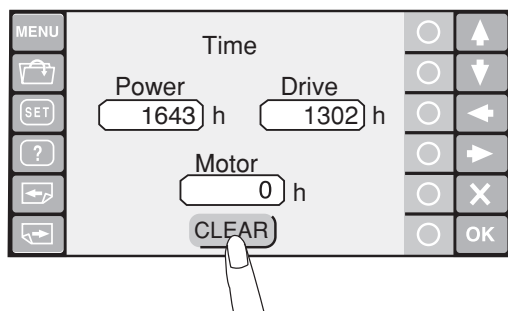
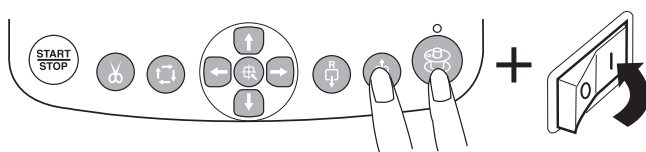

Adjusting the Upper Shaft Timing

1. Remove the spool stand and right cover (see pages 4 and 6).
2. Open the factory adjusting menu window and press the **Phase** key to open the **Phase Sensor** adjusting window.

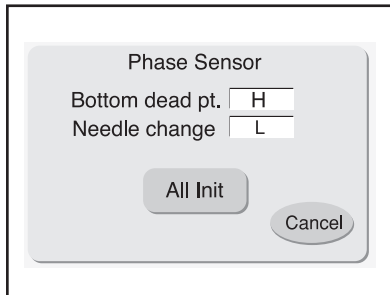

3. Turn the handwheel clockwise.
The indication next to **Bottom dead pt.** should change from "L" to "H" when the index disk is set at 0° (L).
To adjust the bottom dead point (lowest position of the needle) timing, loosen the setscrew on the lowest position shield plate and turn it clockwise until the indication changes from "L" to "H". Tighten the set screw.

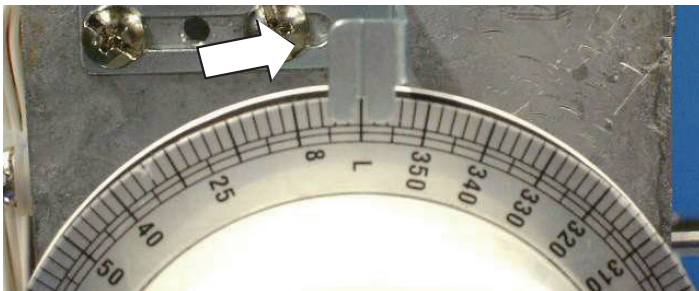

4. Turn the handwheel clockwise.
The indication next to **Needle Change** should change from "L" to "H" when the index disk is set at 270°.
To adjust the needle change position timing, loosen the setscrew on the C point (needle change) shield plate and turn it clockwise until the indication changes from "L" to "H". Tighten the setscrew.

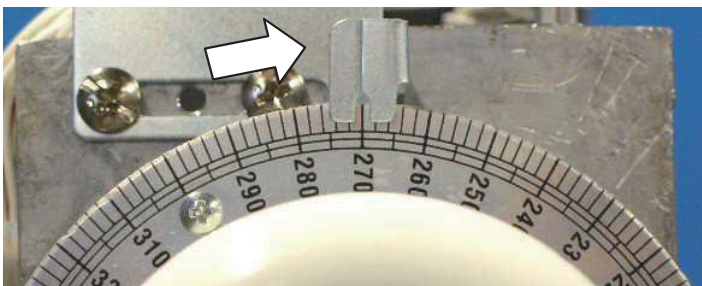

NOTE:
The shield plates should not interfere with the sensors.

5. Attach the parts removed in step 1.

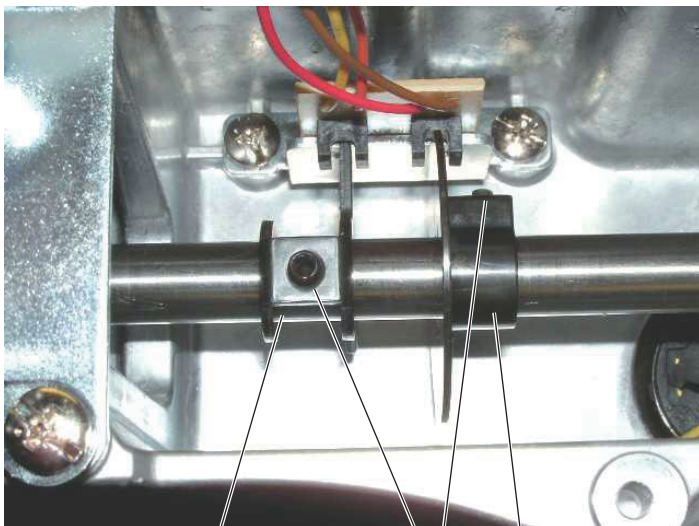

Bottom dead point
(lowest position)
shield plate

Setscrew

C point (needle
change) shield
plate

Adjusting the Moving Head Stop Position

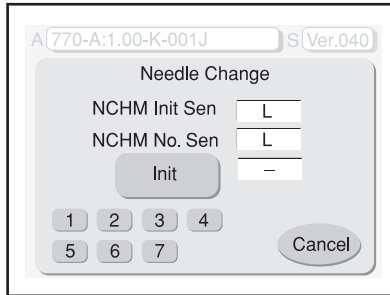

Lateral movement idler gear

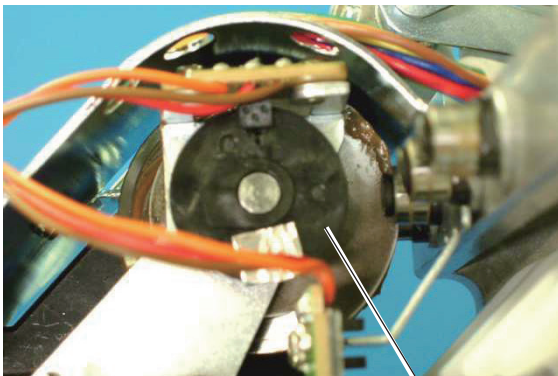
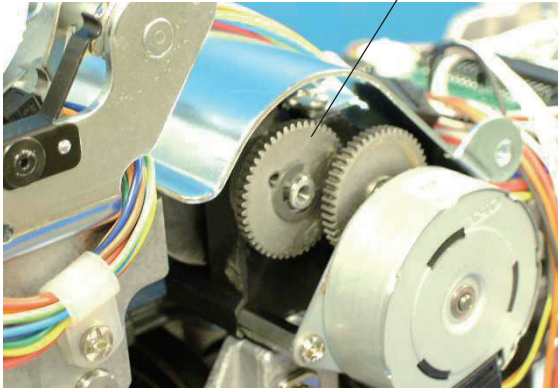

Stop position shield plate

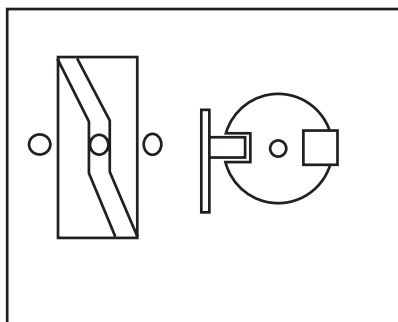

Phase reference of the lateral movement cam and stop position shield plate

Setscrew

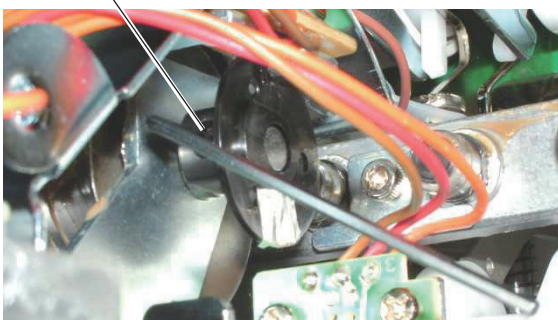

1. Remove the spool stand, right cover, left cover and tension control panel (see pages 4 to 6).
2. Open the factory adjusting menu window and press the **Needle** key to open the **Needle Change** adjusting window.
3. Turn the lateral movement idler gear to set the lateral movement cam at the middle of the flat portion. The indication next to **NCHM Init Sen** should be "H". To adjust the stop position, loosen the setscrew and turn the stop positioning shield plate. Tighten the setscrew.

NOTE:

The shield plate should not interfere with the sensor.

4. Press Init key to move the head to the stop position and check if "L" is indicated.
5. Attach the parts removed in step 1.

Adjusting the Needle Stop Position

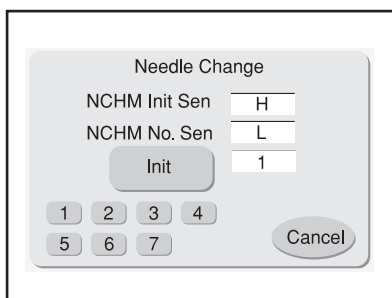

1. Remove the spool stand, right cover, left cover and tension control panel (see pages 4 to 6).
2. Turn the lateral movement idler gear to select needle bar No. 1.
3. Open the factory adjusting menu window and press the **Needle** key to open the **Needle Change** adjusting window.

Lateral movement idler gear

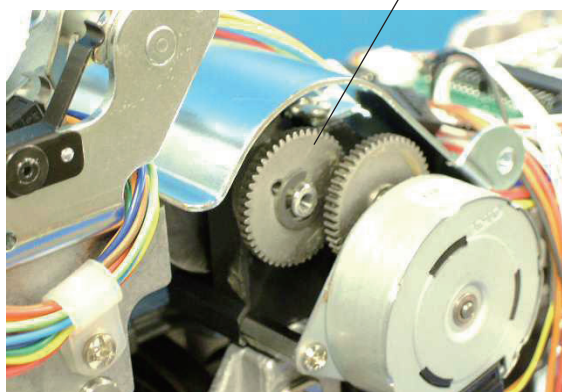

4. Loosen the setscrews (2 pcs.).
5. Move the needle stop sensor to the left until the indication next to **NCHM No. Sen** turns "H".
6. Move the needle stop sensor slowly to the right until the indication next to **NCHM No. Sen** turns "L". Tighten the setscrews.

NOTE:

The sensor should not interfere with the home position dog.

7. Attach the parts removed in step 1.

Home position dog

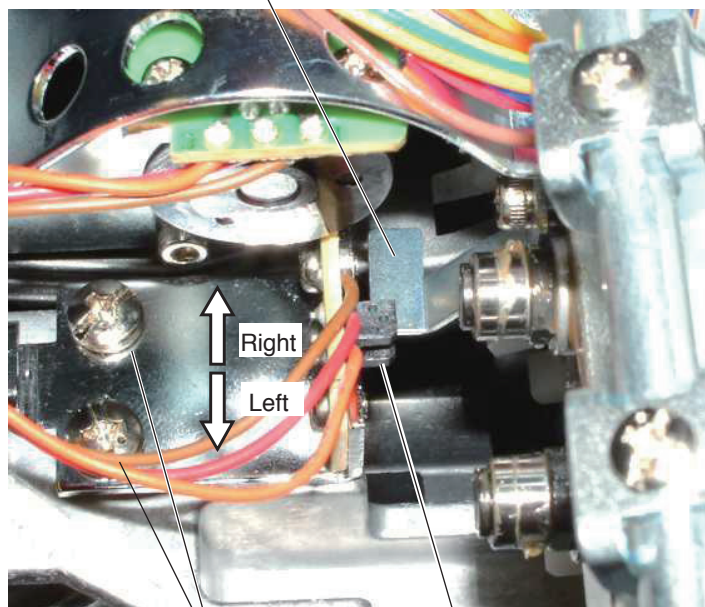

Setscrew

Needle stop sensor

Adjusting the Carriage Home Position

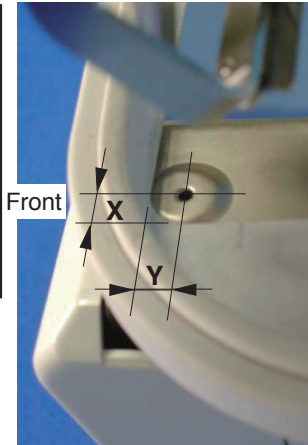
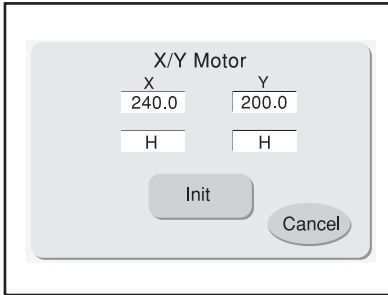

1. Remove the spool stand, right cover, left cover, base cover and X-carriage cover (see pages 4 to 7).
2. Attach the Hoop M1 (MB Hoop 240 X 200) to the hoop supporter.
3. Open the factory adjusting menu window and press the **X/Y Motor** key to open the **X/Y Motor** adjusting window.
4. Press the jog buttons to move the carriage to where the center of the hole in the needle plate is positioned 7 mm by 5 mm from the bottom left corner of the inner sides of the hoop.



5. Loosen the setscrews A (2 pcs.) slightly. Move the Y-carriage sensor plate slowly to the front until the indication under **Y** changes from "H" to "L". Tighten the setscrews A (2 pcs.).

Y-carriage sensor plate
Y-carriage sensor
Jog buttons

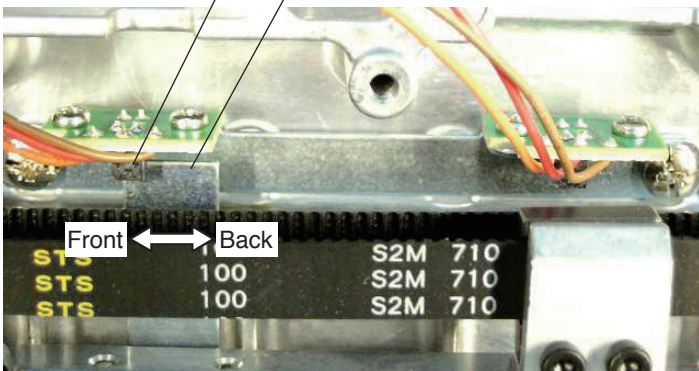

6. Loosen the setscrews B (2 pcs.) slightly. Move the X-carriage sensor plate slowly to the left until the indication under **X** changes from "H" to "L". Tighten the setscrews B (2 pcs.).

NOTE:

The sensors should not interfere with the carriage.

7. Attach the parts removed in step 1.

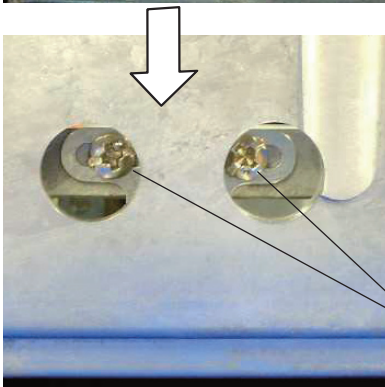

X-carriage sensor
Setscrew A
X-carriage sensor plate
Setscrew B

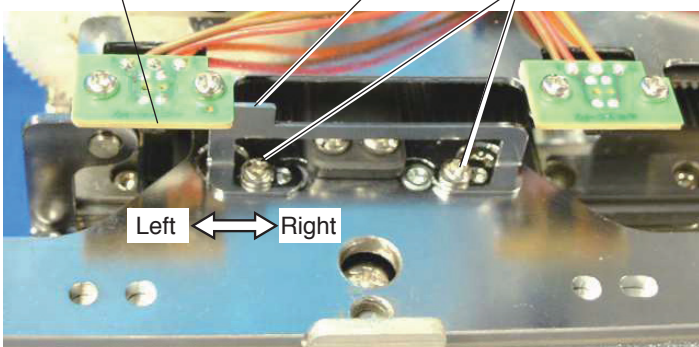

Left
Right

Securing the Cables in the Moving Head (Upper Part)

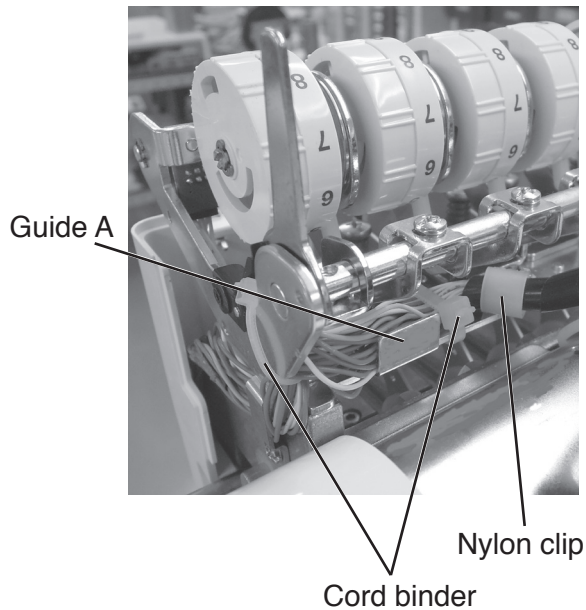

Secure the cables to prevent the cables from getting caught in a slit of thread tensions or interfering with the parts when the moving head moves.

Securing the cables

Bundle the cables with the Nylon clip and secure them with the 2 cord binders as shown.

- * The cables should be inside the guide A when the moving head moves.
- * The cord binders should not interfere with the parts when the moving head moves.

Upgrading Model 770 Series

(Model 770A/MB-4)

For machine of Version 1.00 - 1.40

1. Change the printed circuit board A.
2. Change the printed circuit board B.
3. Change the printed circuit board G and parts of the shielding plate (shown below).

* It is not necessary to update the machine software.

To Change Printed Circuit Board G and Parts of Shileding Plate

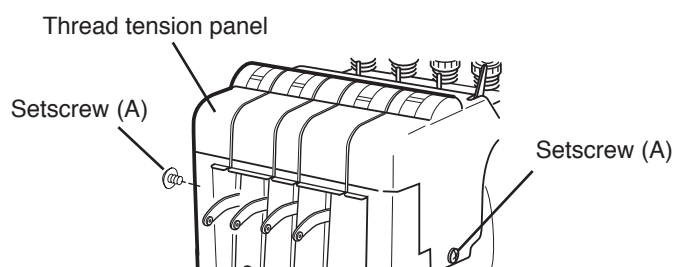

1. Remove the setscrews A (2 pcs.) and thread tension panel.

(Current thread tension unit)

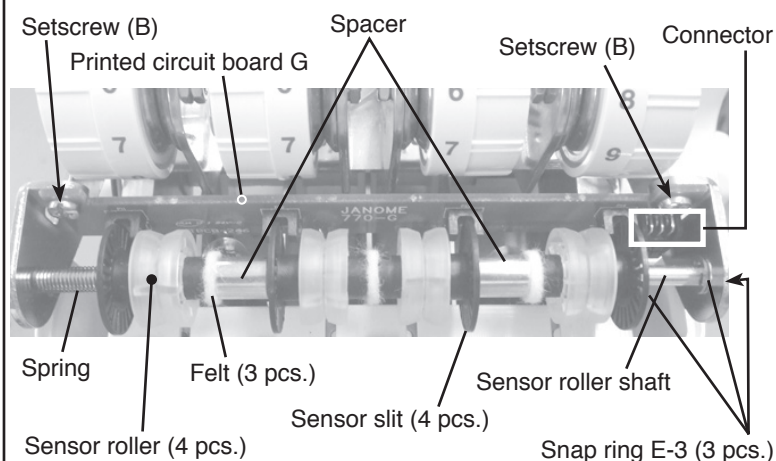

2. Disconnect the connector from the printed circuit board G.
3. Remove the setscrews B (2 pcs.) and printed circuit board G.
4. Remove the snap ring E-3 (3 pcs.). Remove the sensor roller shaft, spring and sensor slits (4 pcs.) .

(New thread tension unit) ... New parts indicated with number

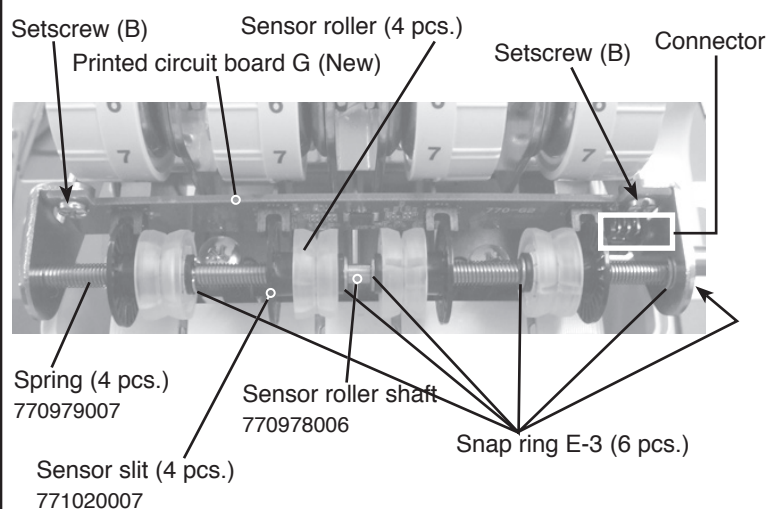

5. Insert the new sensor roller shaft. Attach the new springs, new sensor slits and current sensor roller; and secure them with snap ring E-3 (6 pcs.).
6. Attach the printed circuit board G with set-screws B (2 pcs.).
7. Connect the connector to the printed circuit board G.
8. Attach the thread tension panel.

(Model 770A/MB-4)

For machine of Version 1.41 or later

Machine with the improved thread breakage sensor:

1. Change the printed circuit board G.
2. Change parts of the shielding plate (see page 65).
3. Update the machine software to Version 3.00.
4. Adjust the “Bobbin Thread Break Adjust” value from “20” to “59”.

Entering the Factory Setting Mode and Adjusting “Bobbin Thread Break Adjust” Value

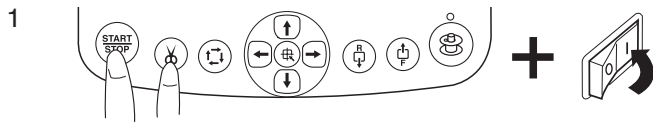

1. Turn the power switch ON while pressing the Start/Stop button and the thread cutter button to enter the factory setting mode.

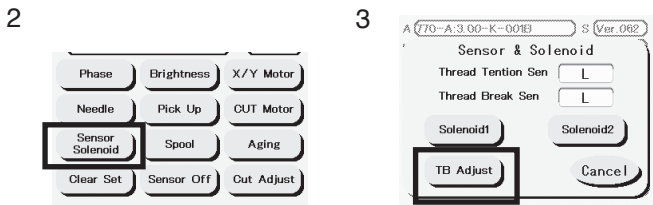

2. Press “Sensor Solenoid” key.
3. Press “TB Adjust” key.

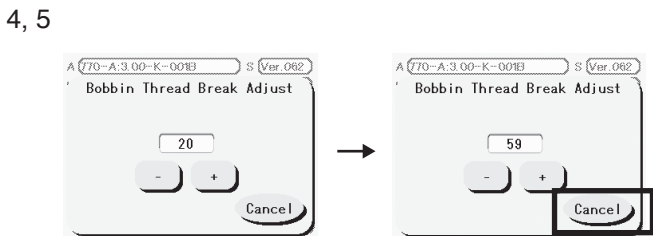

4. Adjust the “Bobbin Thread Break Adjust” value from “20” to “59” by pressing “+” key.
5. Press “Cancel” key to memorize the value.

Machine with the original thread breakage sensor:

1. Update the machine software to Version 3.00.
 - * It is not necessary to adjust the “Bobbin Thread Break Adjust” value.

(Model 770A2/MB-4S)

For machine of Version 2.00 or later

Machine with the improved thread breakage sensor:

1. Change the printed circuit board G.
2. Change parts of the shielding plate (see page 65).
3. Update the machine software to Version 3.00.
4. Adjust the “Bobbin Thread Break Adjust” value from “20” to “59” (see page 66).

Machine with the original thread breakage sensor:

1. Update the machine software to Version 3.00.
 - * It is not necessary to adjust the “Bobbin Thread Break Adjust” value.

(Model 770B/NS-4)

For machine of Version 1.00 - 1.10

1. Change the printed circuit board A.
 2. Change the printed circuit board B.
 3. Change the printed circuit board G and parts of the shielding plate (see page 65).
- * It is not necessary to update the machine software.

For machine of Version 1.11

Machine with the improved thread breakage sensor:

1. Change the printed circuit board G.
 2. Change parts of the shielding plate (see page 65).
 3. Update the machine software to Version 3.00.
 4. Adjust the "Bobbin Thread Break Adjust" value from "20" to "59" (see page 66).
-

Machine with the original thread breakage sensor:

1. Update the machine software to Version 3.00.
- * It is not necessary to adjust the "Bobbin Thread Break Adjust" value.

(Model 770B2/NS-40)

For machine of Version 2.00

Machine with the improved thread breakage sensor:

1. Change the printed circuit board G.
 2. Change parts of the shielding plate (see page 65).
 3. Update the machine software to Version 3.00.
 4. Adjust the "Bobbin Thread Break Adjust" value from "20" to "59" (see page 66).
-

Machine with the original thread breakage sensor:

1. Update the machine software to Version 3.00.
- * It is not necessary to adjust the "Bobbin Thread Break Adjust" value.