

OPERATING INSTRUCTION

For your safety.....

1. Always turn off the power and unplug from the outlet.
When leaving the machine unattended.
When attaching or removing parts.
When cleaning the machine.
When the electric current is shut off.
2. During operation, keep an eye on sewing area.
Do not touch moving parts such as the Thread take-up lever, Hand wheel, Needle.

Before sewing

1. Clean the machine with soft cloth to prevent oil and dust from the machine.
Do not use thinner, benzine, etc. for cleaning.
2. Do not use the machine except as described in these instructions.

1 Names of parts

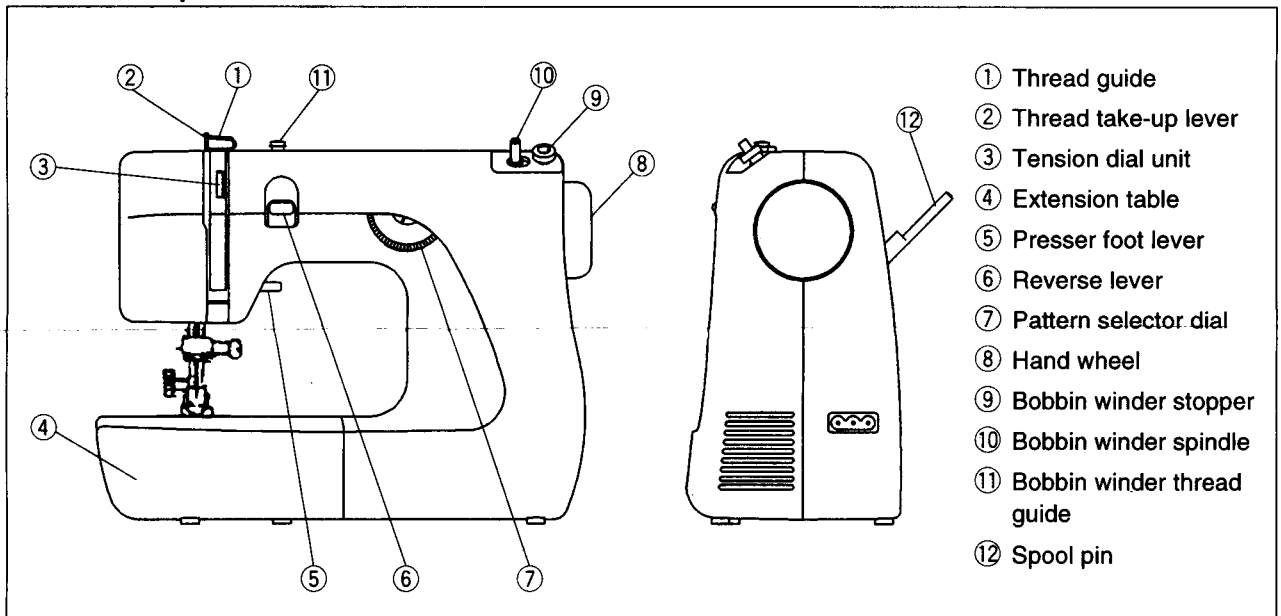

2 Free Arm sewing

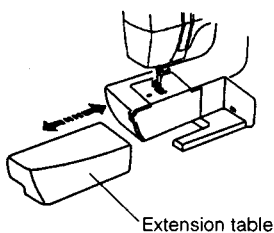

For Free Arm sewing, slide the Extension table to the left and remove.

To replace Extension table.

Slide the Extension table along the Free Arm inserting tab into the slot.

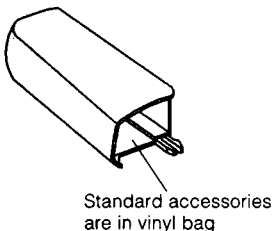

Accessory kit.

Standard accessories located inside the Extension table.

3 Standard accessories



Bobbins



Needles



Seam ripper



Felt

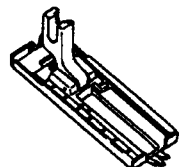

Buttonhole foot

4 Power Connection

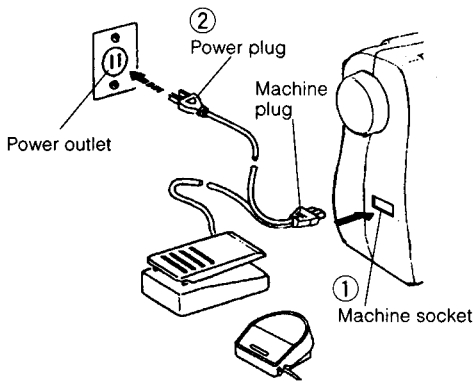

- ① Insert the Machine plug into the Machine socket.
 - ② Insert the Power plug into the Power Outlet.
- * Pull out the Power plug when the Machine is not in use.

5 Speed Control

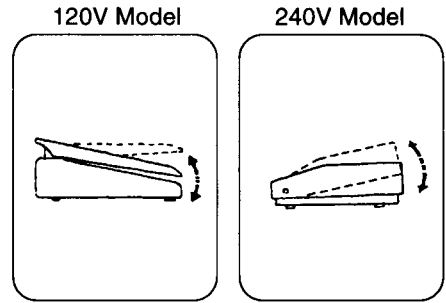

The Foot Control regulates sewing speed.
To increase speed, press down with foot.
To decrease speed, release foot pressure.

6 Adjust the Presser foot lever

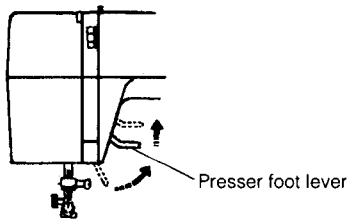

The Presser foot lever raises and lowers the Presser foot.
You can raise it about 1/4" higher than normal up position.
This helps when removing the Foot or when sewing thick material.

7 Needle removal and replacement

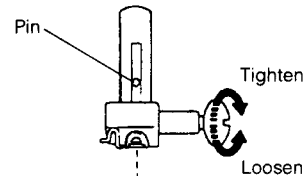

(To remove the Needle)
Loosen the Needle clamp screw by turning it toward you.
Remove the Needle by pulling it downward.

(To replace the Needle)
Insert new Needle into the Needle clamp with flat side away from you.
Push the Needle up as far as it will go.
Tighten the Needle clamp screw firmly with the Screw driver.

8 Sewing light

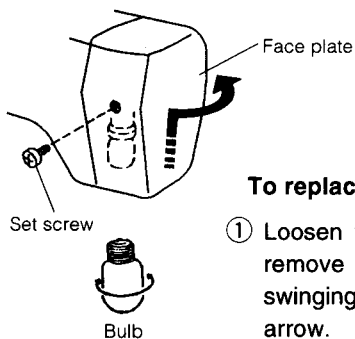

To replace Bulb

- ① Loosen the Set screw and remove the Face plate by swinging it to the direction of arrow.
- ② Turn Bulb counterclockwise to remove.
- ③ Turn the Bulb clockwise to replace.

9 Spool pin

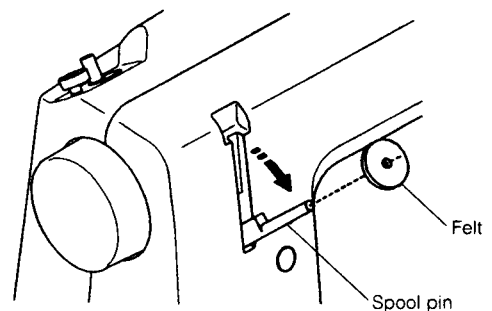

The Spool pin holds the spool of the thread for feeding into the Machine.

To use, turn the Spool pin to the back.

10 Removal and replacement the Bobbin case

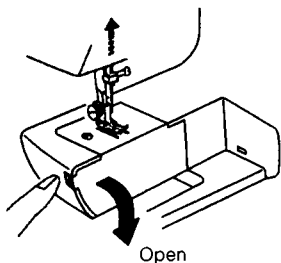

Open the Hook cover.

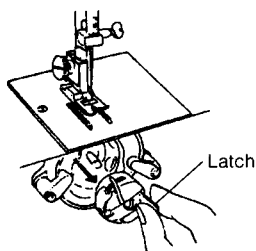

Raise the Needle by turning the Hand wheel toward you.

Lift the Latch and pull out the Bobbin case.

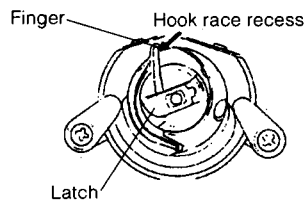

When inserting the Bobbin case, place the Finger into the recess of the Hook race.

11 Winding the Bobbin

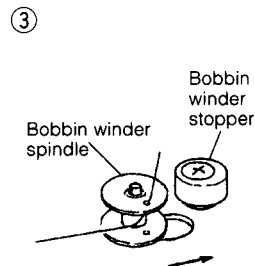
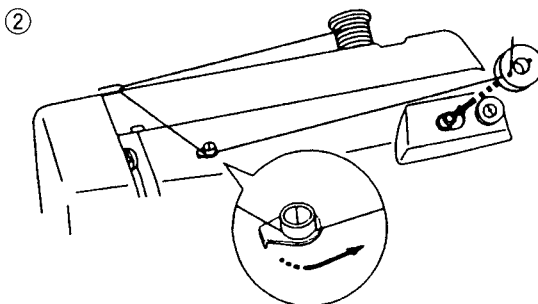
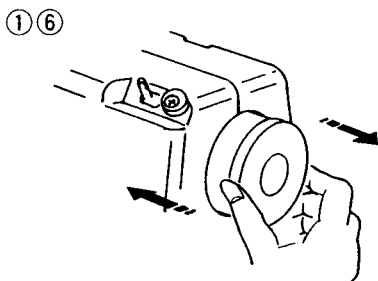

- ① Pull the handwheel out to the right.
- ② Pull the thread from the spool and draw it around the thread guides.
- ③ Draw the thread through one of the holes in the bobbin from inside to outside, put the bobbin on the bobbin winder spindle and push to right.
- ④ Hold the free end of the thread in your hand and depress the foot control.
- ⑤ Stop the machine when it has made a few turns. Cut the thread close to the hole in the bobbin. Depress the foot control again.

When the bobbin is fully wound, push the bobbin winder spindle to the left and cut the thread.

- ⑥ Push the handwheel in.

Note: When you move the bobbin winder spindle, do not operate your sewing machine.

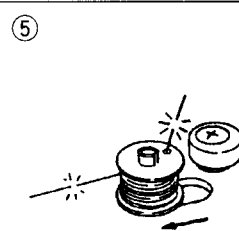
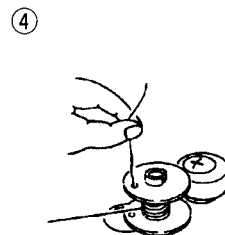

12 Threading the Bobbin case

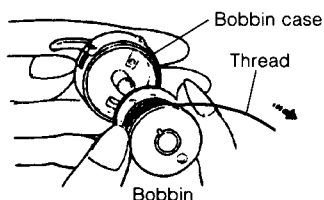

- ① Place the Bobbin into the Bobbin case.
Make sure the Thread unwinds in direction of ARROW.



- ② Pull the Thread into the Bobbin case slot.

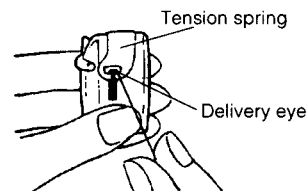

- ③ Draw the T thread under the Tension spring and into the Delivery eye.
Pull out about 10 cm (4 inches) of the Thread.

13 Threading the Machine

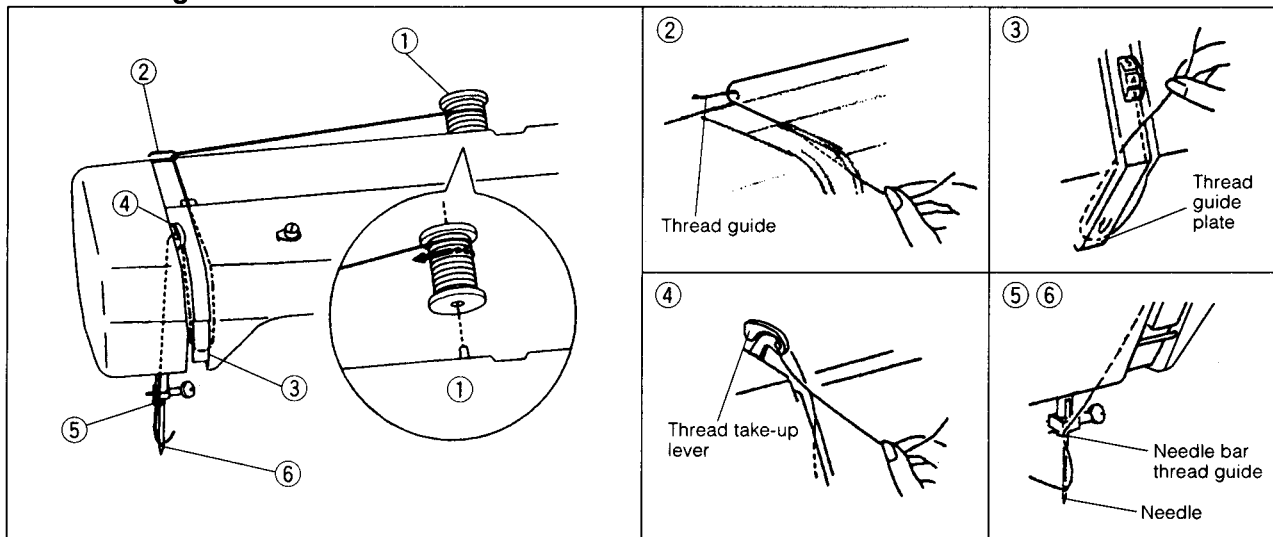

Raise the Thread Take-up lever to its highest position by turning the Hand Wheel toward you.
Raise the Presser foot.

- ① Place the Spool on the Spool pin as shown, with the thread coming from the front of the Spool.
- ② Draw the thread around the Thread guide as shown.
- ③ Draw the thread around the Thread guide plate as shown.
- ④ Pull the thread up, then through the Thread take-up lever from right to left.
- ⑤ Draw the thread and slip it into the Needle bar thread guide.
- ⑥ Thread the Needle eye from front to back. Pull out about 10 cm (4 inches) of the thread.

14 Drawing up the Bobbin thread

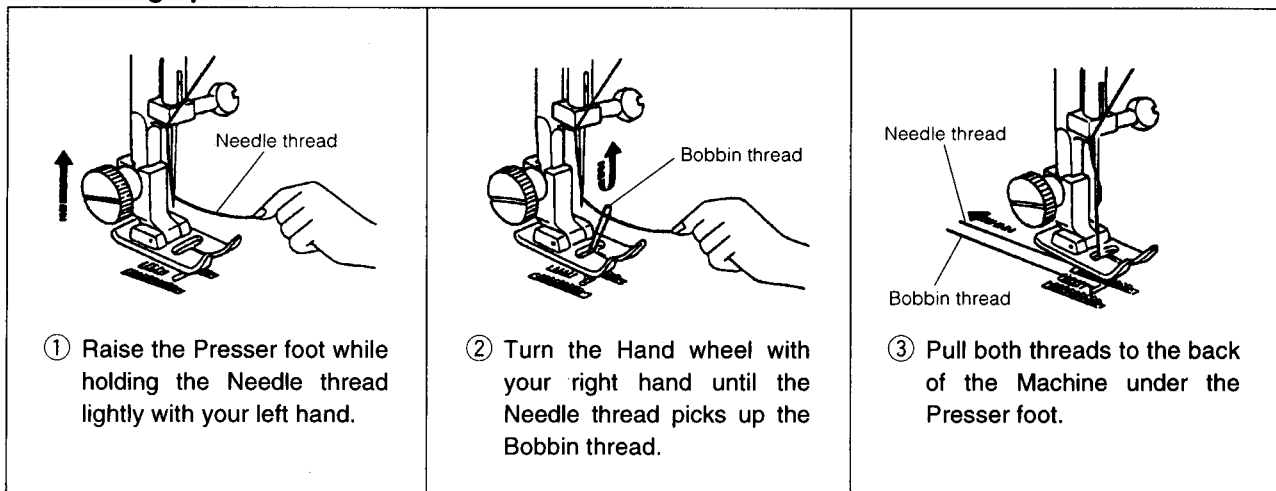

- ① Raise the Presser foot while holding the Needle thread lightly with your left hand.

- ② Turn the Hand wheel with your right hand until the Needle thread picks up the Bobbin thread.

- ③ Pull both threads to the back of the Machine under the Presser foot.

OPERATING INSTRUCTION:

The symbol "0" of a switch indicates the "off" position of a switch.

"For appliances with a polarized plug (one blade wider than the other).

To reduce the risk of electric shock, this plug is intended to fit in a polarized outlet only one way.

If the plug does not fit fully in the outlet, reverse the plug.

If it still does not fit, contact a qualified electrician to install the proper outlet.

Do not modify the plug in any way."

"Foot Controller Model YC-482J or TJC-150 for use with Sewing Machine Model 639."

(For U.S.A. Market Only)

15 Stitch selection

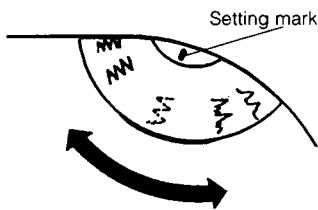

1. Raise the Needle above the fabric.
2. Turn the Dial until the desired stitch pattern is at the Setting mark.

Do not turn the dial while the Needle is in the material.
(The Needle may break.)



16 Reverse lever

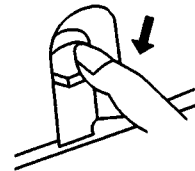

As long as you keep the Reverse lever depressed, the Machine sews backwards.

17 Straight stitch sewing

Machine setting

Stitch

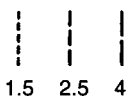

Thread tension dial

2 ~ 6

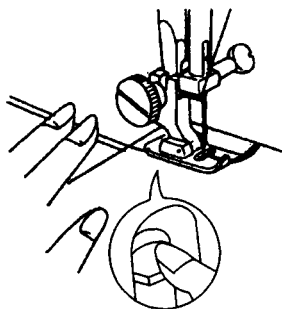

Before sewing

Raise the Presser foot and position the fabric next to a stitching guide line on the Needle plate.

Lower the Needle into the fabric.

Lower the Presser foot and smooth the threads toward the back.

Depress the Foot control.

* To fasten the beginning of a seam, press the Reverse lever and sew several reverse stitches.

To change sewing direction

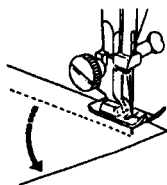

Stop the Machine and turn the Hand wheel toward you to bring the Needle down into the fabric.

Raise the Presser foot.

Pivot the fabric around the Needle to change sewing direction as shown.

Seam ends, thread cutting

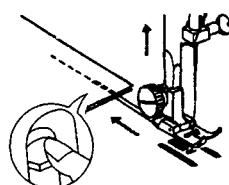

To fasten seam ends, press the Reverse lever and sew several stitches.

Raise the Presser foot and remove the fabric, drawing the threads to the back.

Thread cutting groove

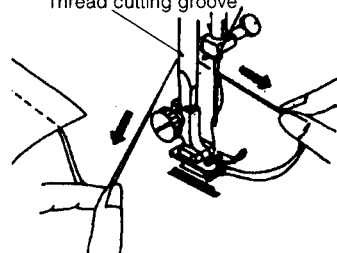

Cut the threads end by inserting them in the Thread cutting groove as shown.

18 Zigzag stitching and Overcasting

Machine setting

Stitch

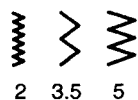

Thread tension dial

2 ~ 5

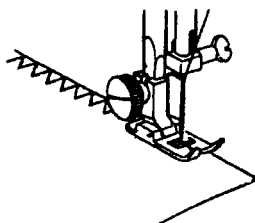

This type of stitch is used to prevent fabrics from fraying at the edges.

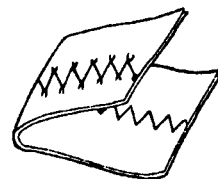

* Before the actual sewing, try sewing with a piece of similar fabric to find the correct thread tension.

< Thread tension for Zigzag sewing >



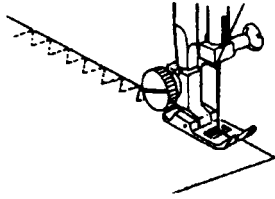

To obtain better Zigzag stitches, the upper tension should be slightly weaker than normal. The upper thread appear slightly on the wrong side of the fabric.

19 Tricot stitch

Machine setting	
<p>Stitch</p>  <p>Thread tension dial 3 ~ 6</p> 	 <p>Place the fabric under the Presser foot so that the edge is just inside the right side of the Presser foot. Guide the work so the right-hand stitches fall at the edge of the fabric.</p>

20 Sewing Buttonholes

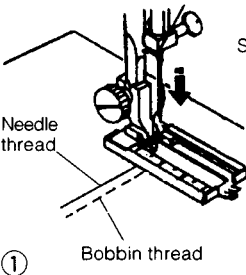
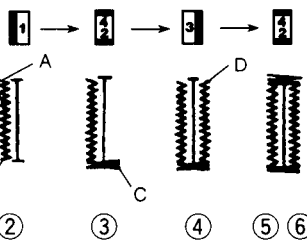
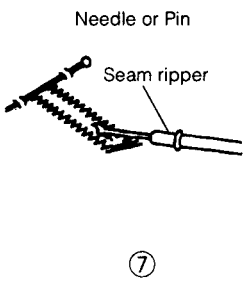
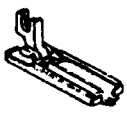
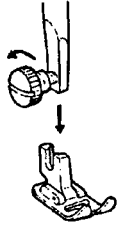
Machine setting	
<p>Stitch</p>  <p>Thread tension dial 1 ~ 5</p> 	 <p>Start mark</p>  <p>Stitch selector dial</p>  <p>Needle or Pin</p> <p>Seam ripper</p>
<p>Buttonhole foot</p> 	<p>* Make a test Buttonhole using the same fabric and interfacing as the actual garment.</p> <p><Procedure></p> <ol style="list-style-type: none"> ① Raise the Needle and set the Stitch selector dial to 1. Slide both threads to the left. Lower the Needle into the garment where the Buttonhole is to start, and lower the Buttonhole foot. ② Sew down the left side stopping at the bottom mark(B). ③ Raise the Needle and set the Stitch selector dial to 2. Sew 5 stitches of bartack and stop the Machine. ④ Raise the Needle and turn the Stitch selector dial to 3. Sew up the right side of the Buttonhole, stop the Machine when you are directly opposite the first stitch on the left hand side. ⑤ Raise the Needle and set the Stitch selector dial to 4. Sew 5 stitches of Bartacks and raise the Needle from the fabric. ⑥ Raise the Presser foot, remove the fabric from the Machine and cut the sewing threads. (Leave 10 cm fortifying) ⑦ Insert a Pin at the end of the Buttonhole, as shown, then cut the opening with a Seam ripper. Take care not to cut the stitches.
<p>Changing the Presser foot</p>  <p>Loosen the thumb screw and replace the presser foot. Tighten the thumb screw.</p>	

Sewing Corded Buttonholes

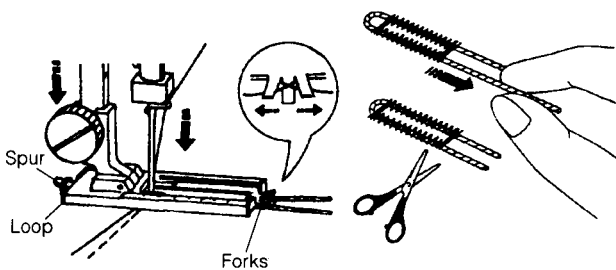

- ① With the Buttonhole foot raised, hook the filler cord on the Spur on the back of the Foot. Bring the ends toward you under the Foot until they clear the front end. Hook the cord ends into the Forks on the front of the Foot to hold them tight.
- ② Lower the Needle into the fabric where the Buttonhole will start and lower the Foot. Sew as you would a normal buttonhole (See above).
- ③ Pull the left end of the filler cord to tighten it, and cut.

21 Blind hemming

Machine setting

Stitch



Thread tension dial 1 ~ 4

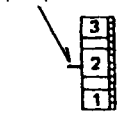

Wrong side of fabric

0.4 ~ 0.7 cm

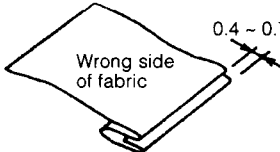
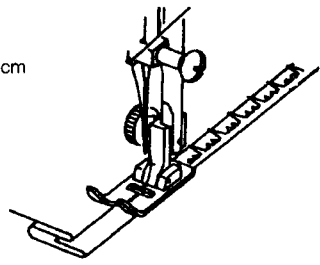
Wrong side of fabric

Right side of fabric

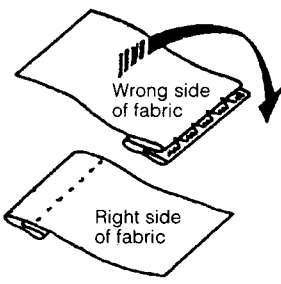

<Procedure>

- ① Fold up the fabric as illustrated.
- ② Lower the Foot, stitching slowly for better control so that the Zigzag stitches fall on the Hem allowance and pierce the soft fold.
- ③ Spread the fabric flat with the right side facing up.

22 Shell tuck

Machine setting

Stitch



Thread tension dial 3 ~ 9

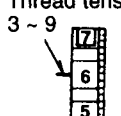
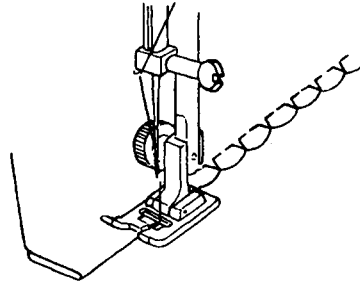



<Procedure>

Place the folded edge along the slot on the Foot. The Needle should fall off the edge of the fabric on the right forming a Tuck.

23 Balancing Needle thread tension



Correct thread tension for Straight stitches

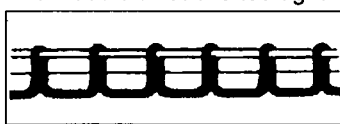

The Needle thread is too tight.



Decrease Tension

The Needle thread is too loose.

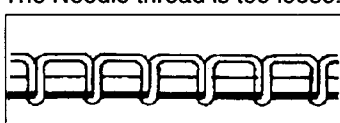

Increase Tension

24 Matching Fabric, Thread and Needle Types.

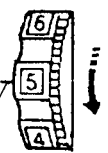
	Fabric	Thread	Needle
Fine	Crepe de Chine, Voile, Lawn, Organdy, Georgette.	Fine Silk Fine Cotton Fine Synthetic.	#9 #11
Normal	Cotton, Pique, Serge, Percale.	50 Silk 50-80 Cotton 50-60 Synthetic	#11 #14
Heavy	Denim, Tweed, Gabardine, Coating.	50 Silk 40-50 Cotton 40-50 Synthetic	#14 #16

- * In general, Fine threads and Needle are used for sewing thin fabrics, and Thicker threads and Needle are used with Heavy fabrics. Always test Thread and Needle size on a small piece of fabric which will be used for actual sewing.
- * Use the same Thread for Needle and Bobbin.
- * When sewing Stretch, very Fine Fabrics and Synthetic, use a Blue Tip Needle.

CARE OF YOUR MACHINE

25 Cleaning the Feed dog

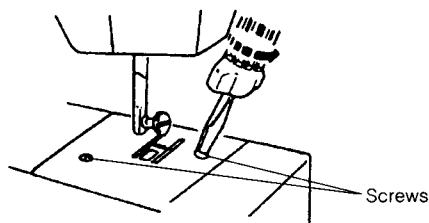

- ① Remove the Needle and the Presser foot.
- ② Remove the Needle plate screws and remove the Needle plate.

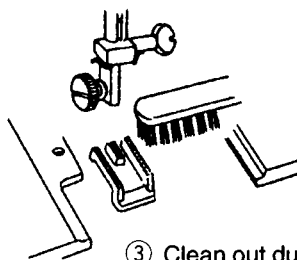

- ③ Clean out dust and lint clogging on the Feed dog teeth with a brush.
- ④ Replace the Needle plate.

26 Dismantling and Assembling Hook race

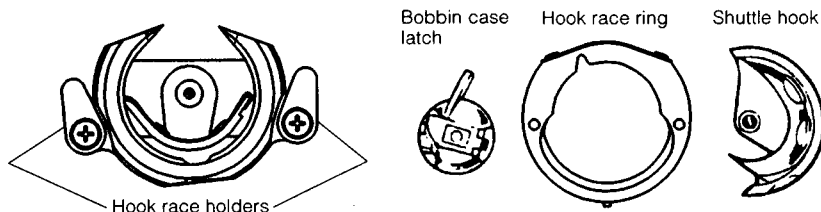

- ① Raise the Needle to its highest position and open the Hook cover. Open the Bobbin case latch and pull the Bobbin out of the Machine.
- ② Open the Hook race holders and remove the Hook race ring and Shuttle hook.
- ③ Clean the Hook race with a Brush and a Soft dry cloth.
- ④ Clean the Shuttle hook.
- ⑤ Replace all parts by following directions in reverse.

27 Trouble shooting

Problem	Cause	Setting
The Needle thread breaks.	<ol style="list-style-type: none"> 1. The Needle thread is not threaded properly. 2. The Needle thread tension is too tight. 3. The Needle is bent or blunt. 4. The Needle is incorrectly inserted. 5. The thread is either too heavy or too fine for the Needle. 	See No. 13 See No. 23 See No. 7 See No. 7 See No. 24
The Bobbin thread breaks.	<ol style="list-style-type: none"> 1. The Bobbin thread is not threaded properly in the Bobbin case. 2. The Bobbin case tension spring set screw is too tight. 3. Lint has collected in the Bobbin case. 	See No. 12 See No. 12 See No. 26
The Needle breaks.	<ol style="list-style-type: none"> 1. The Needle is incorrectly inserted. 2. The Stitch selector dial has been turned while the Needle was in the material. 3. The Needle is too fine for the fabric being sewn. 	See No. 7 See No. 15 See No. 24
Skipping stitches	<ol style="list-style-type: none"> 1. The Needle is incorrectly inserted or bent. 2. The Needle and/or Thread is not suitable for the material being sewn. 3. A Blue tip needle is not being used when sewing Stretch, very Fine fabrics, Synthetics. 4. The Needle thread is not threaded properly. 	See No. 7 See No. 24 See No. 24 See No. 13
Seam puckering	<ol style="list-style-type: none"> 1. The Needle thread tension or Bobbin thread tension is too tight. 2. The Needle and/or Bobbin thread are not threaded properly. 	See No. 23 See No. 12, 13
Stitches form loops below the work.	<ol style="list-style-type: none"> 1. The Needle thread tension is too loose. 2. The Needle is either too heavy or too fine for the thread. 3. The Needle and/or Bobbin thread are not threaded properly. 	See No. 23 See No. 24 See No. 13
The cloth is not feeding.	<ol style="list-style-type: none"> 1. The Feed dog is packed with lint. 	See No. 25
The Machine does not work (Noise, Slow speed).	<ol style="list-style-type: none"> 1. The Feed dog or Shuttle hook area is packed with lint. 2. The Shuttle hook needs to be oiled. 	See No. 25, 26 See No. 26