

INSTRUCTION BOOK

MODEL **S-750**

- 23. Balance wheel
- 24. Machine socket
- 25. Power switch
- 26. Presser foot lifter

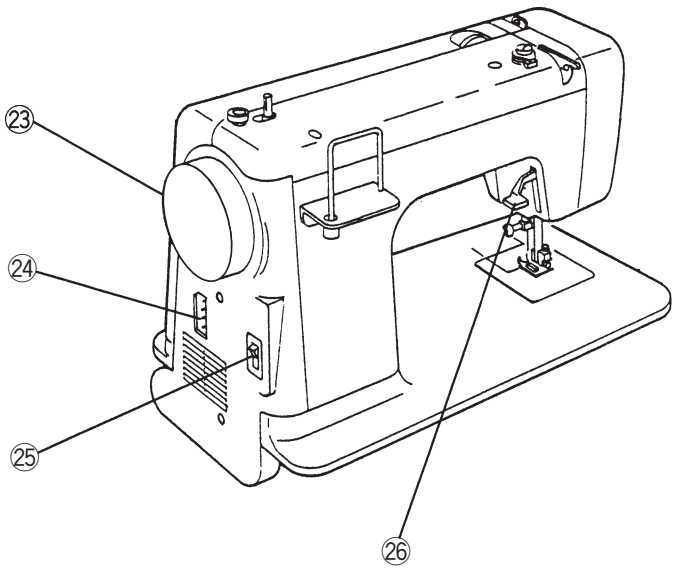

● Standard Accessories

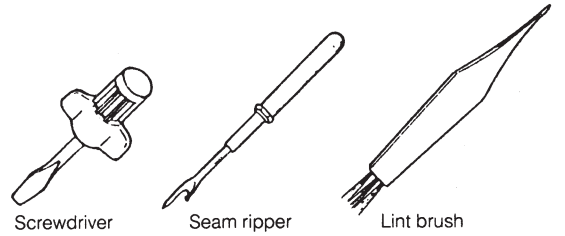

Screwdriver

Seam ripper

Lint brush

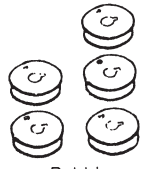

Bobbins



Set of needles



Oil



E: Zipper foot



D: Hemmer foot



C: Overedge foot

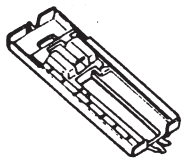

J: Sliding buttonhole foot

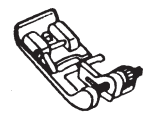

G: Blind stitch foot

• How to Install the Spool Pin

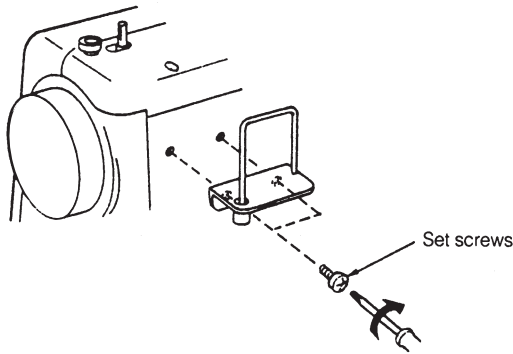

Spool pin and two set screws are separately packed to prevent damage in transit.

Therefore, attach the holder of spool pin in place with a screw driver, as shown in the figure.

• Fundamentals of Operation

For Your Safety

1. While in operation, always keep your eyes on the needle, and do not touch any moving parts such as the take-up lever, balance wheel or needle.
2. Always turn off the machine, and unplug from the power supply:
 - * When making any adjustment in the needle area, such as threading needle, changing needle, or threading bobbin, and the like.
 - * After using the machine.
 - * When leaving the machine for any period of time.
 - * When attaching or removing parts.
 - * When cleaning the machine.
3. Do not place anything on the foot control, except for your foot .

Before Using the Machine

- Wipe the machine with a clean cloth to remove any dust or oil .
- To replace presser foot or needle follow the guides in the instruction book.
- When setting the machine for sewing, test the stitches on a small piece of the fabric with the threads that will be used for actual sewing.

For Longer Life of the Machine

- Do not expose the machine to the sun for long periods of time nor store near a radiator.
- Do not store the machine in an area of high humidity.
- Handle the machine with care to avoid dropping or bumping.

SECTION II GETTING READY TO SEW

• Connecting the Machine to the Power Supply

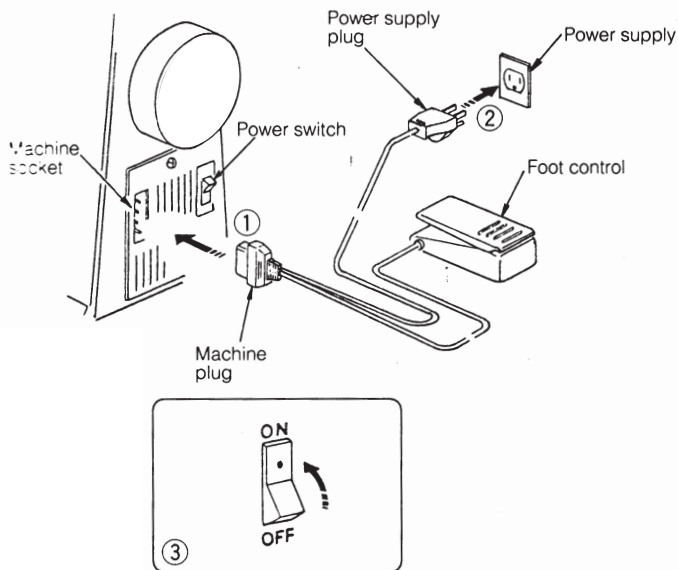

Before connecting the power, make sure the electrical rating (voltage and frequency) of the machine conform to your electrical power.

- ① Turn off the power switch, and connect the machine plug to the machine socket.
- ② Connect the power supply plug to your power supply.
- ③ Turn on the power switch.

• Foot Control

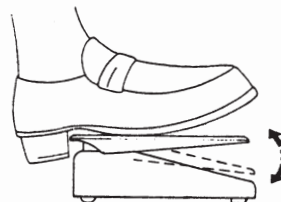

Sewing speed can be varied by the foot control.

The harder you press on the control, the faster the machine runs.

• Replacing Sewing Light

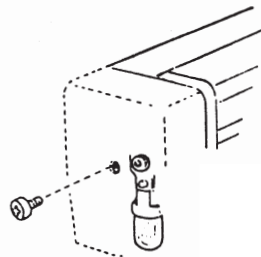

The sewing light is located behind the face plate.

Unscrew the set screw and remove the face plate.

- To remove . . . Turn it counter-clockwise.
- To replace . . . Turn it clockwise.

CAUTION

- * Before removing the face plate, unplug your machine.
- * The sewing light may be HOT. Protect your fingers when you handle it.



• Winding the Bobbin

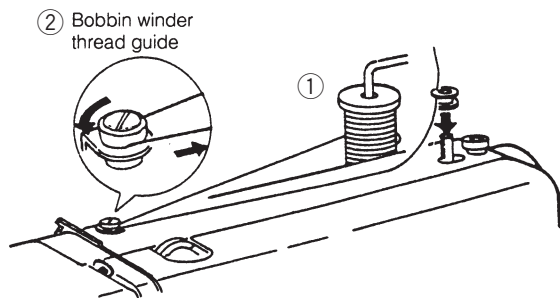

- ① Draw the thread from the spool.
- ② Guide the thread around the bobbin winder thread guide.

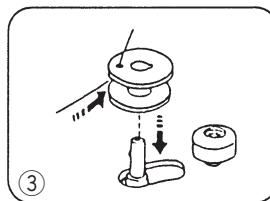

- ③ Insert the thread through the hole in the bobbin from inside to outside as shown.

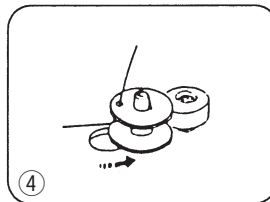

- ④ Put the bobbin on the bobbin winder spindle, and push it to the right.

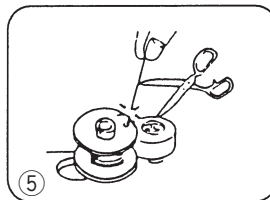

- ⑤ While holding the free end of the thread with your hand, depress the foot control. Stop the machine when it has made a few turns, and cut the thread close to the hole in the bobbin.

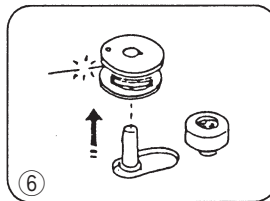

- ⑥ Depress the foot control again and wind the thread until the bobbin stops. Move the bobbin winder spindle to its original position (left), and cut the thread.

* The machine will not sew until the bobbin winder spindle has been returned to the left.

Condition	Cause	Reference
Seam Puckering	<ol style="list-style-type: none"> 1. The needle thread tension is too tight. 2. The needle thread and/or bobbin thread are not threaded properly. 3. The needle is too heavy for the cloth being sewn. 4. The stitches are too coarse for the fabric being sewn. <p>* When sewing extremely light weight materials, place a sheet of paper underneath the fabric.</p>	<p>See Page 13 See Pages 11 ~ 12 See Page 6 See Page 14</p>
Stitches form loops below the work.	<ol style="list-style-type: none"> 1. The needle thread tension is too loose. 2. The needle is either too heavy or too fine for the thread. 	<p>See Page 13 See Page 6</p>
The cloth is not feeding smoothly .	<ol style="list-style-type: none"> 1. The feed dog is packed with lint. 2. The stitches are too fine. 3. The feed dog is not raised after "Drop feed " has been used. 	<p>See Pages 26 ~ 27 See Page 14 See Page 15</p>
The machine does not work.	<ol style="list-style-type: none"> 1. The machine is not plugged in. 2. A thread is caught in the hook race. 3. Bobbin winder spindle is in the winding position. 	<p>See Page 5 See Pages 26 ~ 27 See Page 10</p>
The buttonhole stitches are not balanced.	<ol style="list-style-type: none"> 1. The stitch length is not suitable for the fabric being sewn. 2. The work is being pulled or held back. 	<p>See Page 14 Do not force the fabric for guiding.</p>
The machine is noisy.	<ol style="list-style-type: none"> 1. The machine is in need of oil. 2. Dust and lint have collected in the hook mechanism. 3. The feed dog is packed with lint. 	<p>See Page 28 See Pages 26 ~ 27 See Pages 26 ~ 27</p>

