

JANOME

Quilt Maker Pro

12' Quilting Frame

Assembly Instructions

Table of Contents

Parts List	2	Step 10- Pole to Frame Assembly	21
Hardware List	3	Step 11- Rubber End Cap Assembly	21
Quilt Maker Pro 12' Quilting Frame		Step 12- Hook and Loop Strips Attachment	22
Box Contents	4	Step 13- Bungee Clamp Assembly	22
Step 1- Frame Side Assembly	5	Step 14- Hook and Loop Strips	
Step 2- Table Assembly	6	on Poles Assembly	23
Step 3- Middle Leg Assembly	7	Step 15- Attach Leaders	23
Step 4- End Leg Assembly	8	Step 16- Adjusting Quilt Maker Pro 12'	
Step 5- Precision-Glide Track Assembly	11	Quilting Frame Height	24
Step 6- Ratchet Stop Assembly	14	Loading the Frame & Using the Pole Cradles	25
Step 7- Pole Bracket Assembly	16		
Step 8- Pole Coupler Assembly	17		
Step 9- Pole End Assembly (including			
Ratchet Wheel, Hand Wheel)	18		

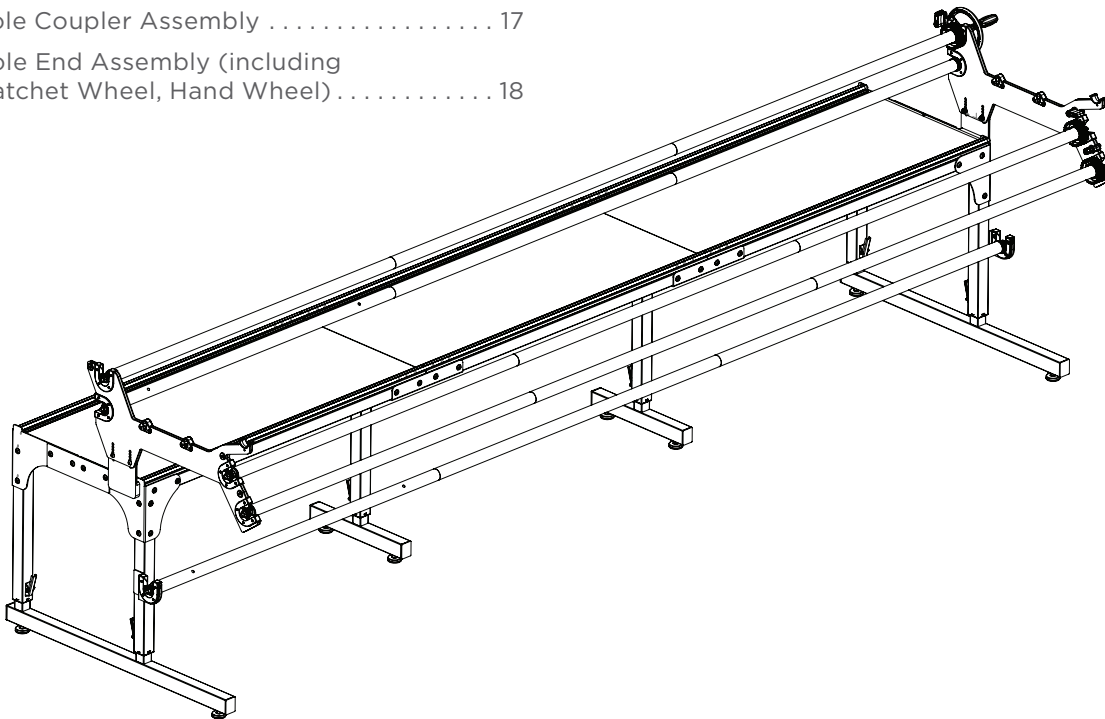

What's Included

Your Quilt Maker Pro 12' Quilting Frame should have been delivered in four separate boxes. Upon opening, please check immediately to see if you have received the items listed in the Parts and Hardware lists found on pages 2, 3 and 4. In addition, the following items will be found in:

Box 1: Quilt Maker Pro 12' Quilting Frame Assembly
Instructions Manual

Box 4: (3) Leaders
(3) Hook and loop strips to attach leaders
to poles

If you find you are missing any items, please contact Janome immediately at 1-800-631-0183 or by emailing custrel@janome-america.com.

Quilt Maker Pro 12' Quilting Frame

Parts List

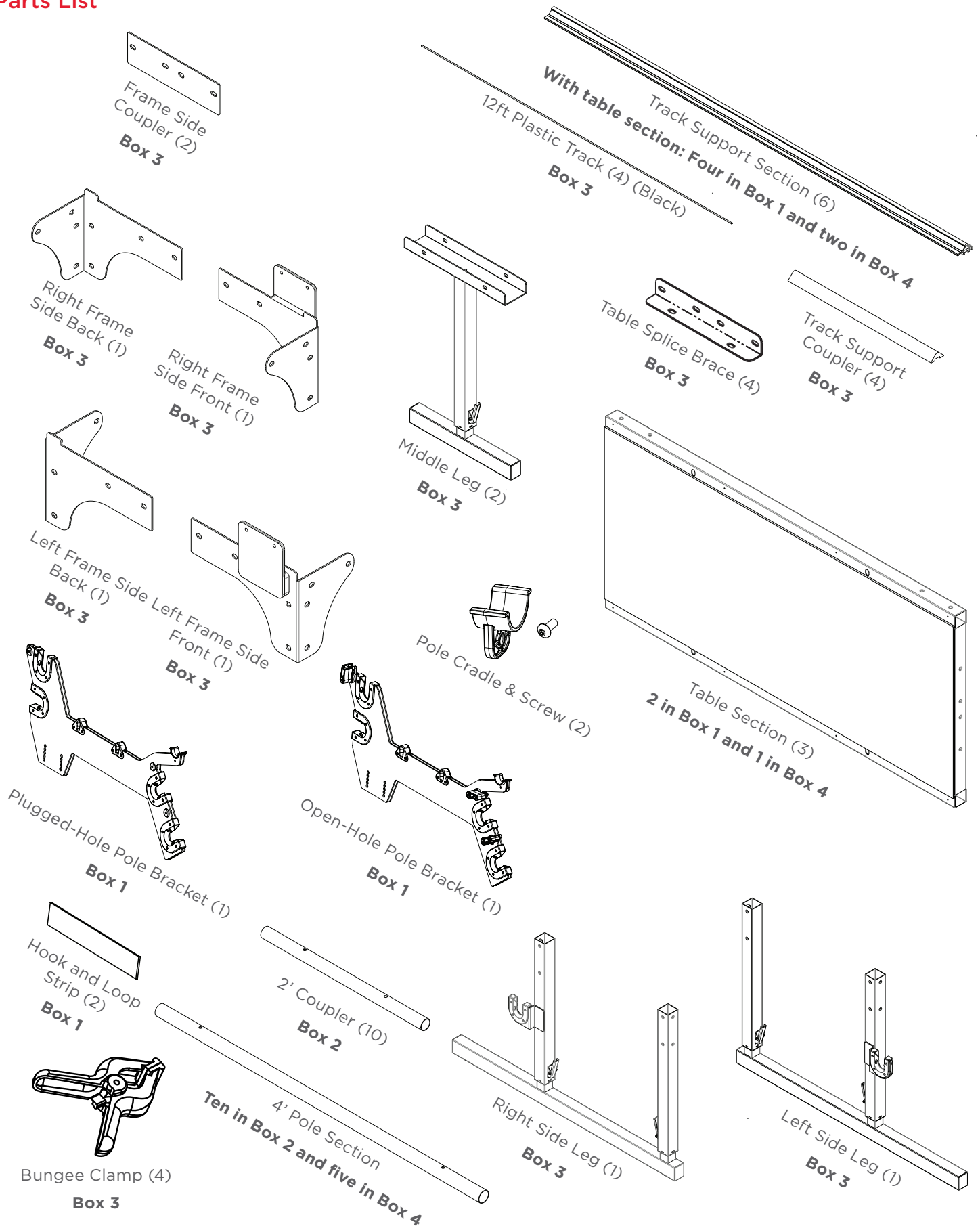

Quilt Maker Pro 12' Quilting Frame Hardware List

These parts found in Box #3



Rubber End Cap (10)

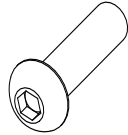

M8 x 25mm
Socket Button
Head Cap Screw
(SBHCS)(4)

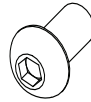

M8 x 16mm Socket
Button Head Cap
Screw (SBHCS)
(64 total)



M8 Lock
Nut (4)



M8 Flat
Washer (4)

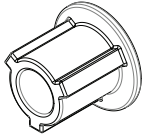

Hand Wheel Insert (1)

**May be preassembled
with Hand Wheel.**



M6 x 12mm
Connector Screw
(12 total)
(8 in Box 1)
(4 in Box 4)



M5 x 8mm
Socket Button
Head Cap Screw
(SBHCS)
(24 total)

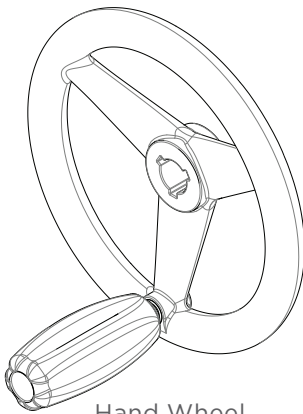

Hand Wheel
Assembly (1)

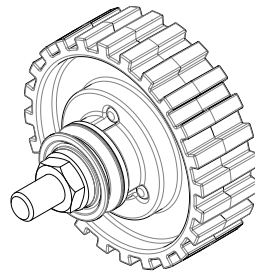

Short Bolt
Ratchet Wheel
Assembly (2)

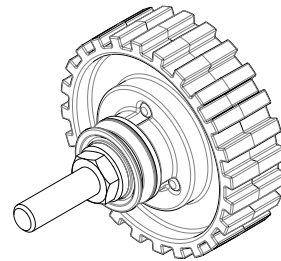

Long Bolt Ratchet
Wheel Assembly (1)

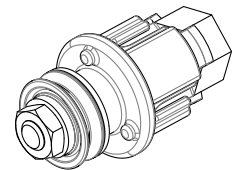

Pole End
Assembly (7)

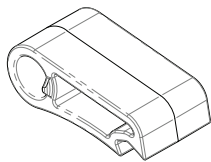

Ratchet Stop
(3)

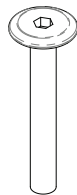

M6 x 45mm
Connector Screw
(3)



Ratchet-Stop
Mount (3)

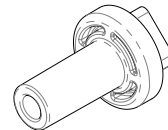

Ratchet-Stop
Bushing (3)



Ratchet-Stop
Holder (3)

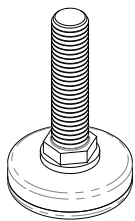

Leveling Foot (8)

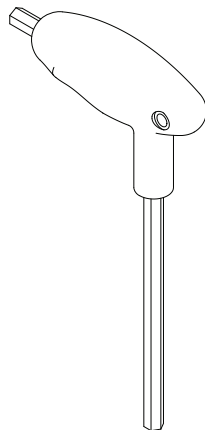

5mm Allen
Wrench (1)

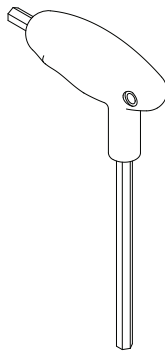

4mm Allen
Wrench (1)

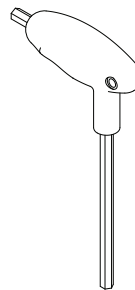

3mm Allen
Wrench (1)

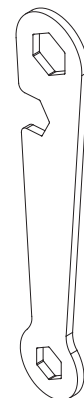

17/13/16mm Wrench (1)

Quilt Maker Pro 12' Quilting Frame Box Contents

12' frame	
Box No.	Parts
1	Two 4-foot table sections with track supports (4), M6 X 12mm Connector screw (8) and left and right pole brackets, 12' assembly instructions
2	10 poles, 10 couplers
3	All other parts (including plastic tracks)
4	One 4-foot table section w/track supports (2), M6 X 12mm Connector screw (4), five 4-foot poles, 11' leaders, velcro set 3

Step 1 - Frame Side Assembly



Note: Assembly is easiest if all connections are finger-tightened first as instructed, while assembling the frame. Tighten with the wrench when instructed.

Why is this important? If you tighten as you go, you may have trouble getting all the parts to align properly.

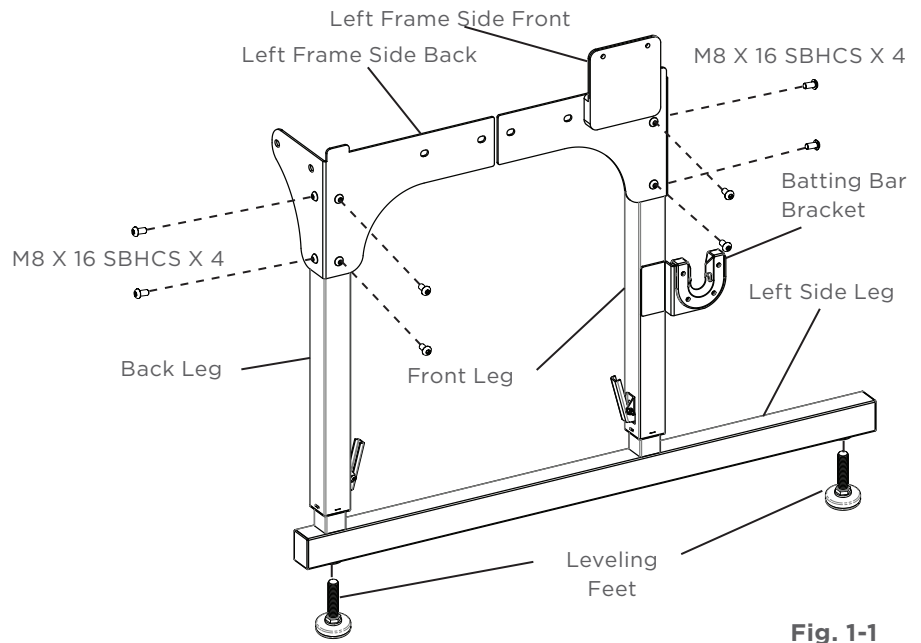

Fig. 1-1



Note: Make sure both height-adjustable legs are at their shortest setting before proceeding.

Remember that the batting bar bracket needs to be on the outside of the leg.

(Fig. 1-1)

Step 1: Frame Side Assembly

Parts needed:

- 1-Right Side Leg
- 1-Left Side Leg
- 1-Right Frame Side Front
- 1-Left Frame Side Front
- 1-Right Frame Side Back
- 1-Left Frame Side Back
- 4-Leveling Feet
- 16-M8 x 16mm SBHCS

Tools Required:

- 5mm Allen Wrench (Provided)

1-1: Screw two (2) leveling feet about half way into the bottom of the left side leg, as shown in Fig. 1-1.

1-2: Attach the left frame side back onto the side leg using two M8 x 16mm SBHCS into the back of the back leg. Next install two more M8 x 16mm SBHCS into the side of the back leg. **Finger-tighten** the screws only for now. You will tighten the screws with an Allen wrench later in Step 4.8.

1-3: Attach the left frame side front onto the side leg using two M8 x 16mm SBHCS into the front of the front leg. Next install two more M8 x 16mm SBHCS into the side of the front leg. Finger-tighten the screws only for now. You will tighten the screws with an Allen wrench later in Step 4.8.

1-4: Using remaining parts, repeat Steps 1-1 through 1-3 to complete the right side leg.

Step 2 Table Assembly

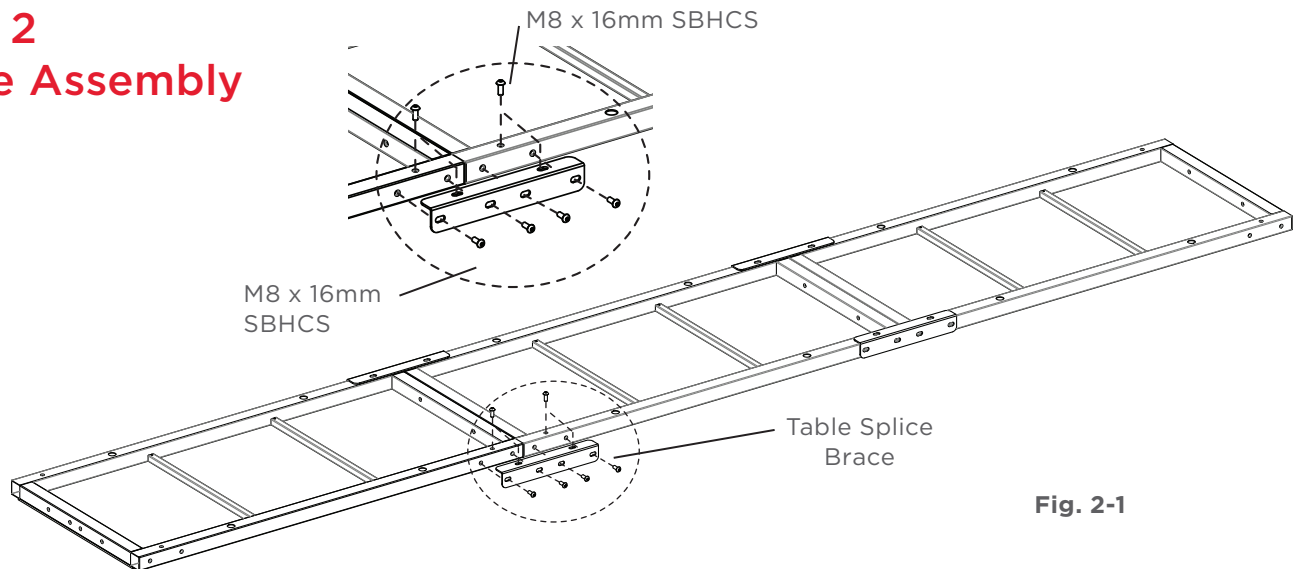

Fig. 2-1



NOTE:

For this step, a carpeted surface is recommended for the protection of your floor and frame.

If you are working on a hard surface (such as tile, hardwoods or concrete), cover the surface with a blanket or rug.



Note:

Skip Steps 2 and 3 if you are only setting the frame up at four feet (4'). The 12' frame uses a 4' center/middle table section.



NOTE:

Remember to finger-tighten all screws first. Once all are in place, then tighten using the 5mm Allen wrench (provided) as instructed.

Step 2: Table Assembly

Parts needed

- 3 - 4' sections
- 4 - Table Splice Brace
- 24 - M8 x 16mm SBHCS

Tools Required

- 5mm Allen Wrench (Provided)

2-1: IMPORTANT: Prepare the three table sections by removing the two track supports screws from each track support. Set the track supports aside. These will be reinstalled in Step 5 see Fig. 5-5.

These were assembled on the table temporarily to protect them during shipping.

2-2: 12 foot: Start with Two 4-foot table sections upside-down on the floor end to end (as shown in Fig. 2-1). Join the sections together by placing a table splice brace onto the sections, lining up the holes in the brace with those in the sections. Make sure the flange portion of the brace is on top (as shown).

2-3: Place four (4) M8 x 16mm SBHCS through the side of each table splice brace and finger-tighten them into the table sections.

2-4: Finger-tighten two (2) SBHCS through the top of each table splice brace (as shown). (Fig. 2-1)

2-5: Repeat Steps 2-1 through 2-3 to add remaining 4-foot section.

2-6: Pull the two table sections as close together as possible to remove gap. (This will facilitate assembly of the middle legs in Step 3.)

2-7: Using the 5mm Allen wrench, tighten the four side screws on each table splice brace, until the brace touches the side of the table frames, and then loosen the screws ½ turn.

2-8: IMPORTANT: Tighten fully the two (2) top screws on each table splice brace, using the 5mm Allen wrench. Now fully tighten the 4 screws on the side of each table splice brace. **All 24 screws should now be tightened.**

Step 3 Middle Leg Assembly

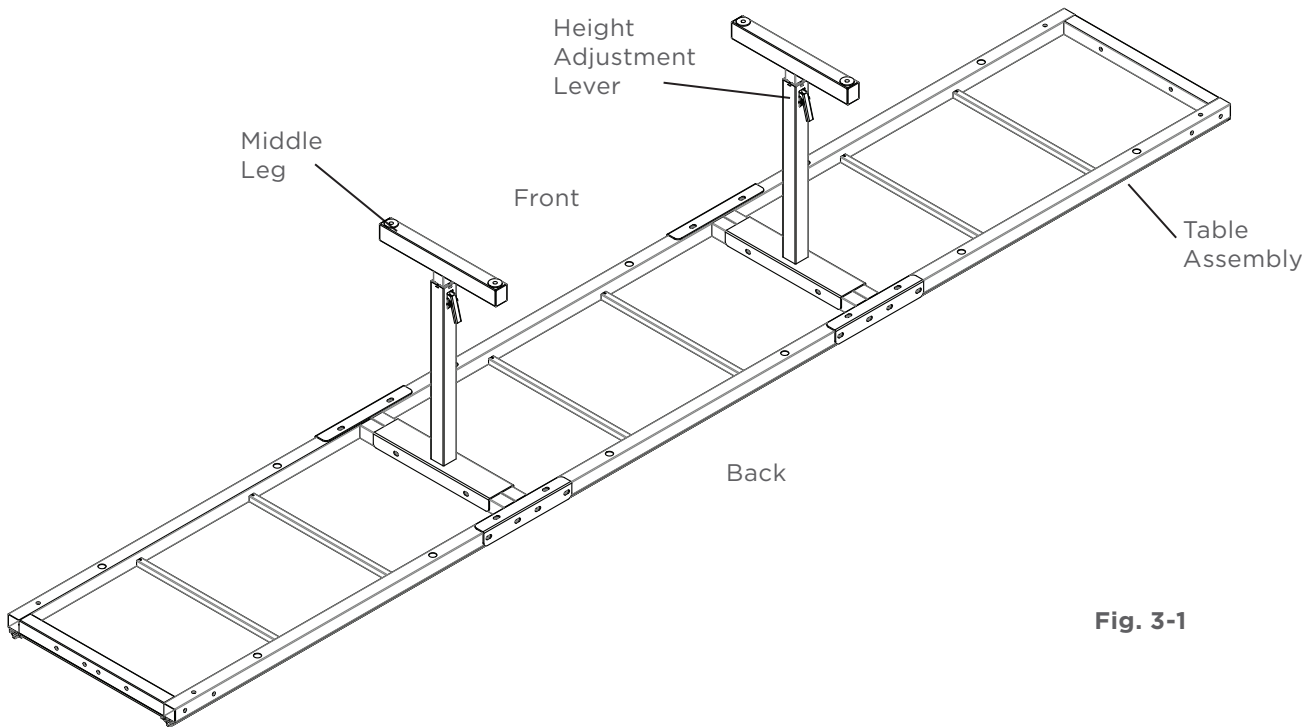

Fig. 3-1



Note: If instructions were carefully followed in Section 2, there should be minimal gap between the table sections where the sections meet. The middle leg/legs should slide over the two table section end tubes easily. Check to ensure that all table splice brace screws are tightened before tightening the four middle leg screws.

Step 3: Middle Leg Assembly

Parts needed

- 1- Table Assembly
- 2- Middle Legs
- 4- Leveling Feet
- 8- M8 x 16mm SBHCS

Tools Required

5mm Allen Wrench (Provided)

3-1: Install two (2) leveling feet about half way into one middle leg.

3-2: Place the middle leg assembly over two joined table sections. Attach the middle leg assembly using four (4) M8 x 16mm SBHCS.

3-3: While pushing down on the leg, fully tighten the four (4) screws.

3-4: Repeat Steps 3-1 through 3-3 to attach remaining middle leg. Be sure middle leg assemblies are set at the lowest settings and that the height adjustment levers are facing in the same direction, towards the back of the table as shown in Fig. 3-1.



Note: The direction the height adjustment levers face determine the back of the frame in this step.

Step 4 End Leg Assembly

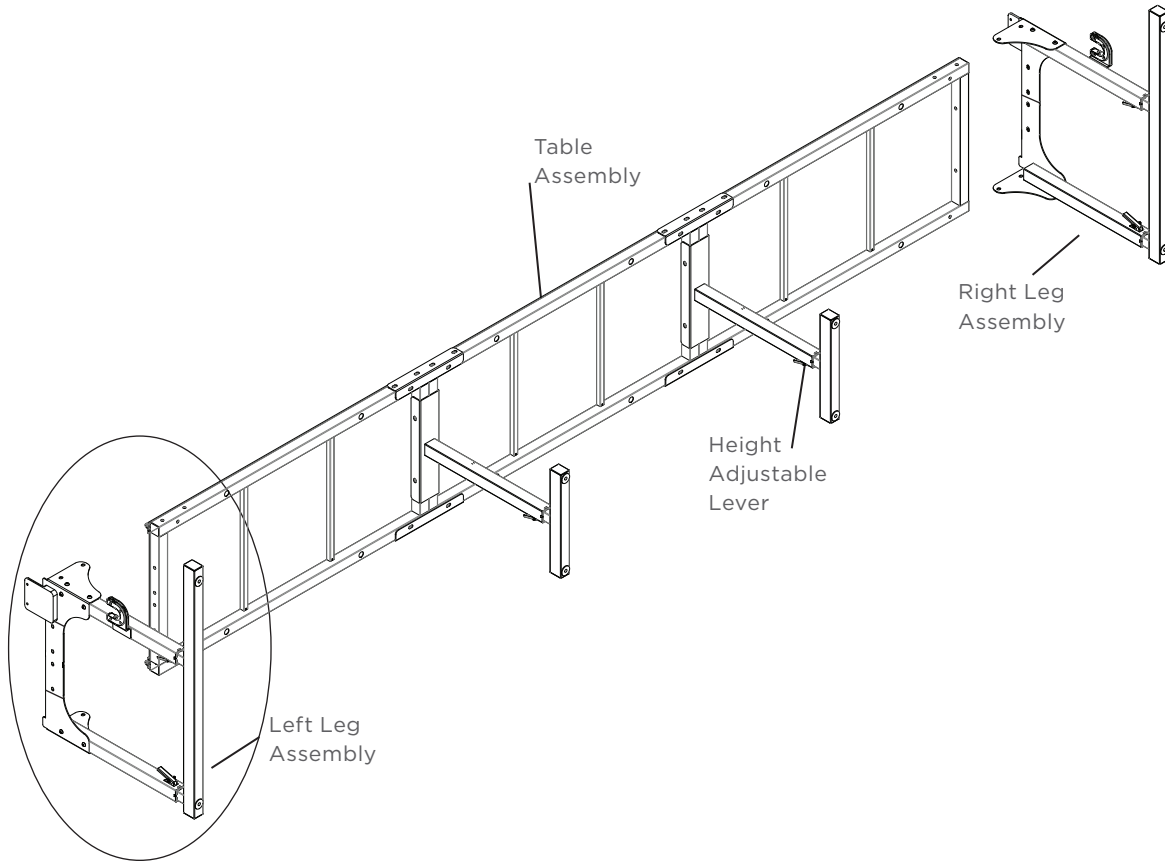

Fig. 4-1



Note: Finger-tighten screws only until all screws are in place, they will be tightened after the table is up- righted once again. See Step 4-8.

Step 4: End Leg Assembly

Parts needed

- 1- Table Assembly
- 1- Right Leg Assembly
- 1- Left Leg Assembly
- 2 - Frame Side Coupler
- 16- M8 x 16mm SBHCS

Tools Required

- 5mm Allen Wrench (Provided)
- Spirit Level (Not Provided)

4-1: In preparation for attaching the left and right leg assemblies to the frame, turn the frame on its side so the height adjustable levers are towards the ground, as shown in Fig. 4-1.

4-2: Slide the left leg assembly under the table assembly.

Step 4 End Leg Assembly (continued)



Note:

Make sure all height-adjustable legs are at their shortest setting before proceeding with Step 4-6.

Step 4: End Leg Assembly (continued)

4-3: Starting at the top left corner, screw two (2) M8 X 16mm SBHCS down through the top corner Left Frame Side Front piece into the table frame Fig. 4-2, **finger-tighten** only.

(Fully tighten in Step 4-8)

4-4: Align the Frame Side Coupler to the holes in the Left Frame Side Front and the Left Frame Side Back and screw four (4) screws thru the Coupler, the Frame Side and into the Table Section Fig. 4-2.

4-5: Repeat **Steps 4-2** through **4-4** for the Right Leg Assembly.

4-6: With the help of a second person, rotate the frame so it is standing in the upright position.

4-7: Attach two (2) M8 x 16mm SBHCS each through the back side of the left and right leg assemblies, and **finger-tighten** only.

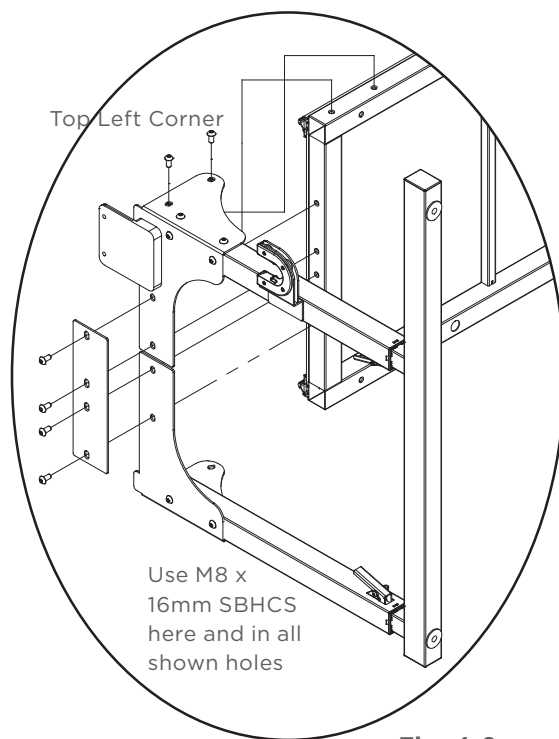

Fig. 4-2

Step 4

End Leg Assembly (continued)

4-8: Next, ensure that the table assembly is down on top of the left and right leg assemblies, at all four corners, by applying the appropriate pressure or support, (there should be little to no gap between the bottom of the table assembly and the top of each leg) see Fig. 4-3. Now using the 5mm Allen Wrench, tighten the 4 screws at each corner to the table assembly (8 screws per end). Also tighten the 4 screws at each frame side to each leg at this time (8 more screws per end). If necessary have a second person help check and hold this while tightening the screws.

4-9: At this point, all screws should be tightened on the table. Double-check all M8X 16mm screws to make sure they are tightened, using the 5mm Allen tool.

4-10: Using a spirit level, check and adjust the frame top to be level in the place where it will be used, both front to back and side to side, by adjusting the leveling feet. Double-check that the table-top frame to ensure that it is flat at each table splice brace and not sagging or high at the joints (Fig. 4-4). If no spirit level is available, check the table with the machine on the carriage and the Precision-Glide tracks after they are installed in Step 5 and adjust appropriately. When the table is level, the machine should stay where you put it and not roll forward, back or side to side.

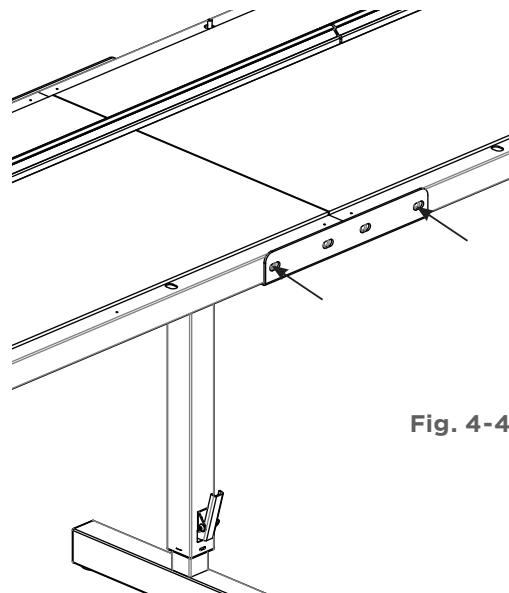
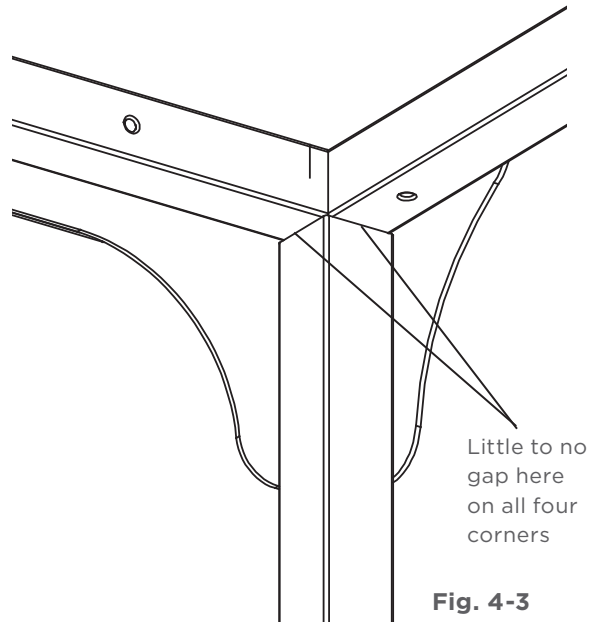

Step 5 Precision-Glide Track Assembly

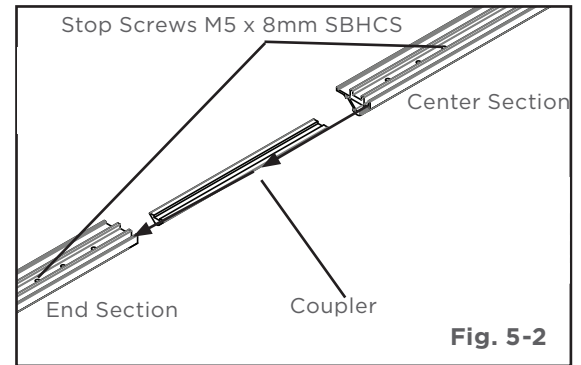
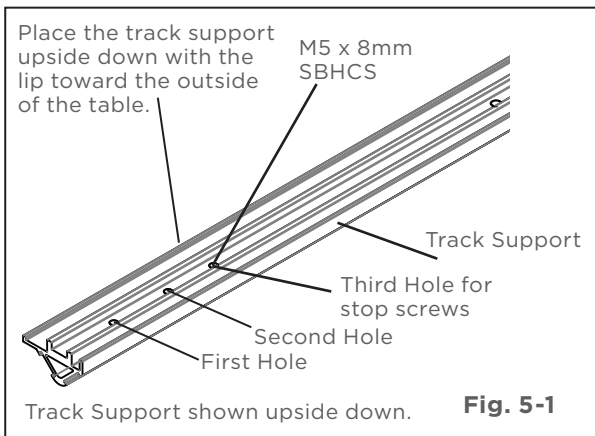

Note: The aluminum track support sections are cut from single sections of extruded aluminum and should align when placed end to end. However, if all directions in Step 5-4 are followed and track supports still do not align properly, try swapping track support sections, so that different ends are joining.

Step 5: Precision-Glide Track Assembly

Parts needed

- 1- Table
- 6- 4-foot Track Support
- 4- Track Support Couplers
- 24- M5 X 8mm SBHCS
- 12- M6 x 12mm Connector Screw
- 4- 12' Plastic Tracks (Black)

Tools Required

- 3mm Allen Wrench (Provided)
- 4mm Allen Wrench (Provided)

5-1: Check inside the ends of the track supports for burrs or debris and remove all foreign matter from the inside.

5-2: Lay three track-support sections on the table upside down, with the wider lip of the sections facing toward the outside of the table (Fig. 5-1).

5-3: To prepare for joining one end and the center support sections together, screw one M5X 8mm SBHCS into the **third hole** from each splice end of each section to serve as a stop screw (Fig. 5-1, Fig. 5-2). Fully tighten screw. This will help align the coupler properly into the two track support sections when joined.

5-4: Insert a coupler into one prepared end of one track support section up to the stop screw. Thread an M5 X 8 mm SBHCS into the first hole and lightly tighten as shown in Fig. 5-2. Insert the other end of the coupler into second prepared track support section. Hold the two adjoining track support sections tightly together and thread an M5 X 8mm SBHCS into the first hole of the second track support and lightly tighten (shown in Fig. 5-2). You may need to gently rock the track support to seat the coupler. Finally, insert a second screw into the track supports, align and tighten.

5-5: Repeat steps 5-3 and 5-4 to join remaining track support section to center track support section to assembly one (1) track support. Once alignment is assured, tighten all screws firmly.

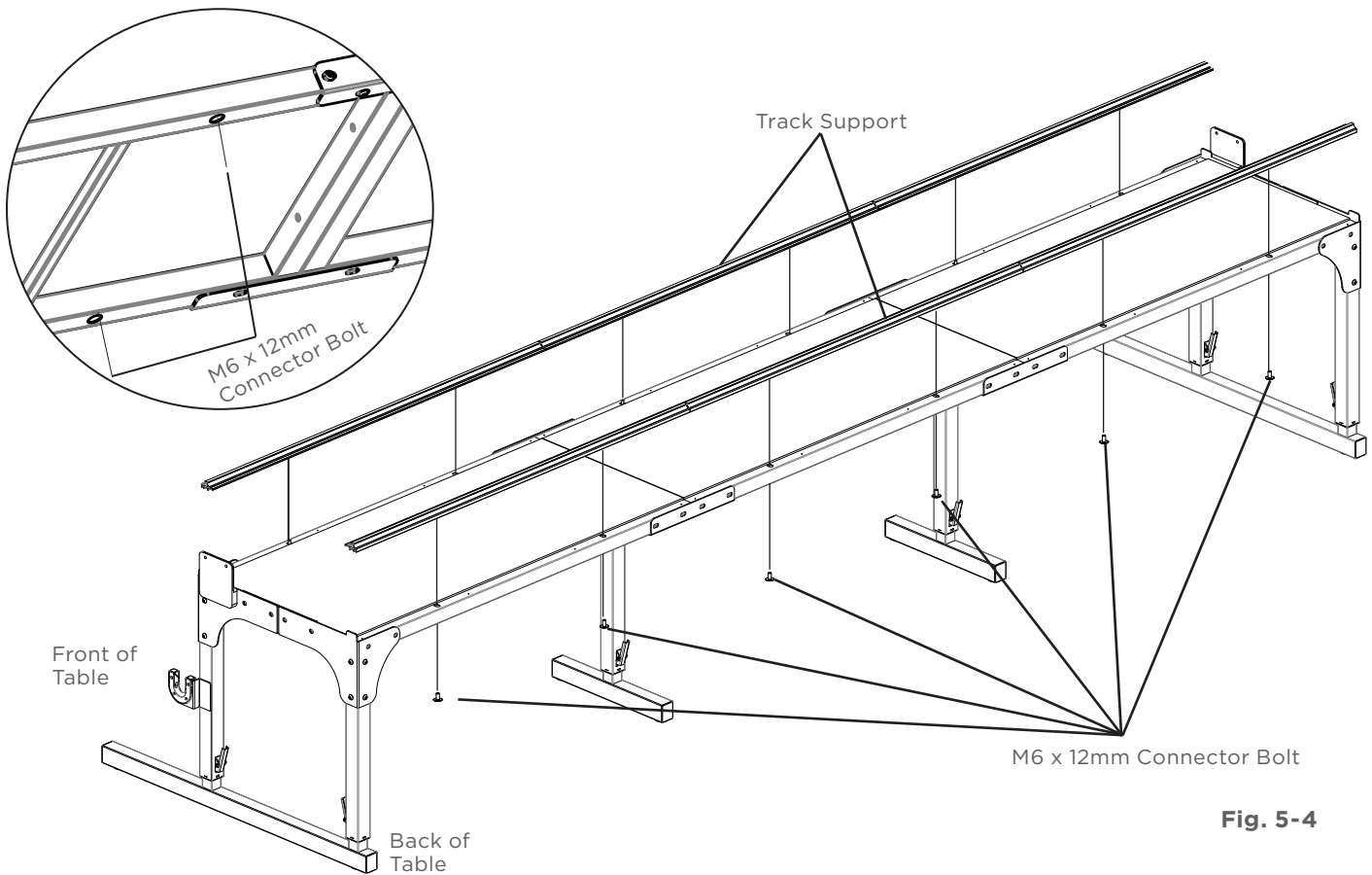



Fig. 5-4

 **Note:** The extrusions have a wider shoulder on one edge of the track. This shoulder is to be placed toward the inside of the table over the edge of the black plastic tabletop. (Fig. 5.5)

5-6: Insert a plastic track completely into one side of the aluminum track supports. The plastic track should slide into the track support easily. If a plastic track binds slightly, try backing the track out a little, then try pushing it further. If the plastic binds badly, check the track supports for debris, burrs, misalignment or damage. (Fig. 5-3)

In same manner, insert plastic track in otherside of the track support.

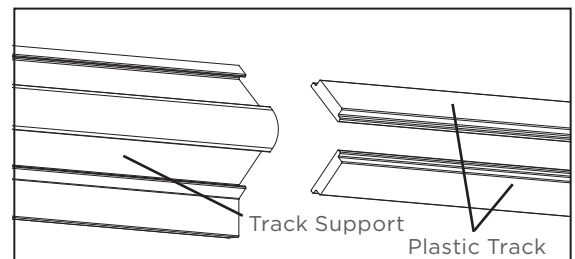



Fig. 5-3

5-7: Repeat **Steps 5-1** through **5-6** to make second track.

 **Note:** The track support surfaces must be perfectly aligned. Otherwise, the quilter will feel a bump and quilt stitches will be adversely affected.

5-8: Attach Tracks. Secure one assembled track to the back of the quilting frame. Line up the track support by holding it tightly against the plastic tabletop as you secure it to the frame, using six (6) M6 x 12mm connector screws, as shown in Fig. 5-4. **IMPORTANT: Do not tighten screws at this time.** They need to be loose to accommodate adjustments in **Step 5-9**. In same manner, attach the remaining track support to the front of the frame using six (6) M6 x 12mm connector bolts.



Fig. 5-5

Step 5 Precision-Glide Track Assembly

5-9: Align Tracks. Place the carriage on the tracks at one end of the table. Roll back and forth along the length of the table, establishing the distance between the two tracks, taking care to check that the wheels are engaging the track on both the front and the back of the carriage. Move both tracks in tandem to the back of table as far as possible. (Slots in the tables allow this movement.) Double-check that the back track is straight along the back edge of the table. Fully tighten the screws in the BACK track only for now.

5-10: Place the machine onto the carriage and again, roll it the entire length of the frame, working the tracks into the wheels as you go. Lightly tighten the front track support screws as you move down the table. Check the carriage to verify that it rolls smoothly and that both ends of the carriage are engaging the tracks.

If you find a section of track where the carriage rocks back and forth when moved all the way forward or back, loosen the front track support screws, and adjust the front track until the carriage rolls smoothly and does not rock, then re-tighten the front track screws.

5-11: Finally, fully tighten the front track to the table.

Step 6 Ratchet Stop Assembly

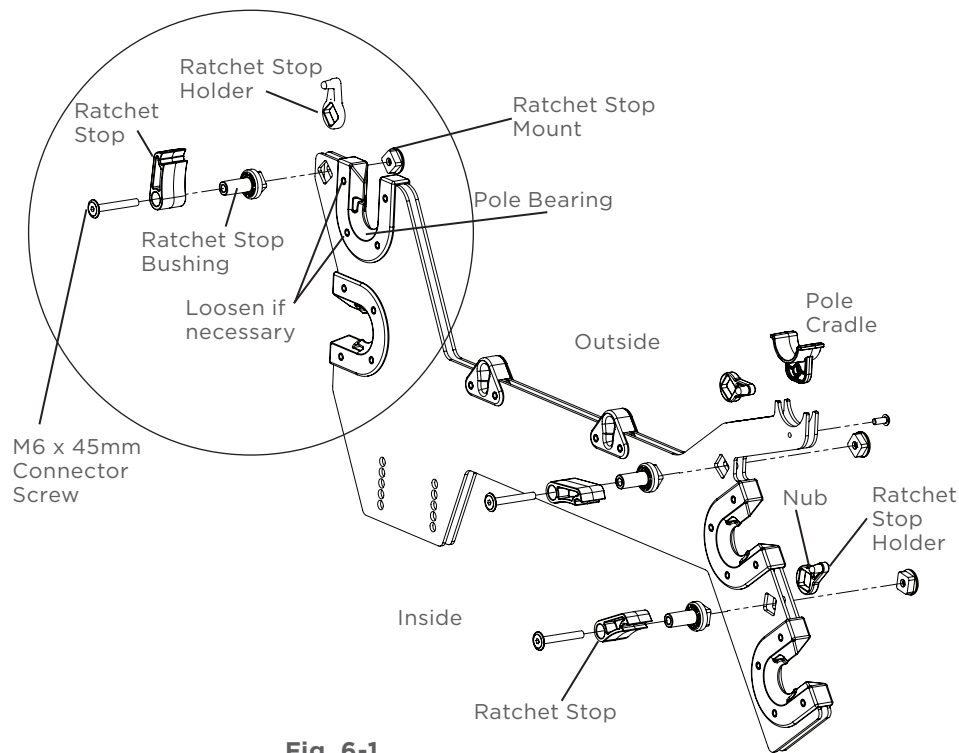

Fig. 6-1

Step 6: Ratchet Stop Assembly

Parts needed

- 1- Open-hole Pole Bracket
- 3- M6 x 45mm Connector Screw
- 3- Ratchet-Stop
- 3- Ratchet-Stop Bushing
- 3- Ratchet-Stop Mount
- 3- Ratchet-Stop Holder

Tools Required

- 4mm Allen Wrench (Provided)

6-1: Decide whether you want the ratchets and hand wheel to be on the left or the right side of the frame. The following instructions show how to assemble the frame with the hand wheel on the right side of the frame, which is the most common setup. If you prefer the hand wheel to be on the left side of the frame, see “Left Side Option” on page 15.

6-2: Identify the open-hole pole bracket and the plugged-hole pole bracket. The plugged hole pole bracket can be used “as-is” on either the left or right side, depending on the decision made about which side the hand wheel will be on. Set the plugged hole pole bracket aside at this time.

The ratchet stops and ratchet-stop holder will be assembled into the open-hole pole bracket, but the orientation of the stops and holders will vary, depending upon whether the pole bracket is used on the right or the left side of the table. The instructions that follow assume that the open pole bracket (and hand wheel) will be used on the right side of the table.

6-3: Place one ratchet-stop holder between the two metal pieces at the back of the open-hole pole bracket, with the stop nub facing inside, as shown in Fig. 6-1. If the ratchet stop holder will not fit, loosen the two pole-bearing screws nearest the square hole. Slide in the ratchet stop holder and re-tighten when finished.

6-4: Following the parts order in the circled detail in Fig. 6.1, thread one M6 x 45mm connector screw through a ratchet stop, ratchet stop bushing, pole bracket (with ratchet stop holder inserted) and finally into the ratchet-stop mount. Pay close attention to the orientation of the ratchet stop. Tighten with the 4mm Allen tool until the ratchet stop holder nub holds the ratchet stop, see Fig 6-2 circle detail.

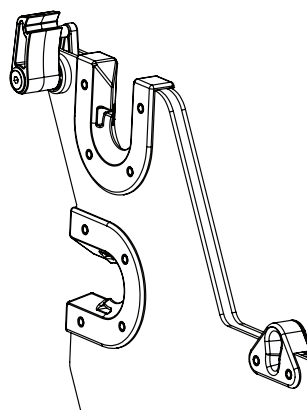

Fig. 6-2

6-5: In same manner, attach the remaining ratchet stops and ratchet stop holders to the front of the pole bracket, paying attention to the orientation of the ratchet stops (Figs. 6-1 through 6-3) to create the right pole bracket.

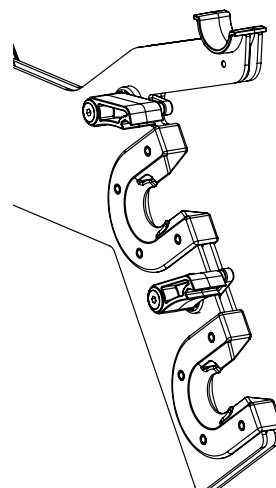

Fig. 6-3

6-6: Attach the pole cradles following Fig 6-4. Note that their orientation should allow for the wider section of the cradle to face towards the inside of the frame.

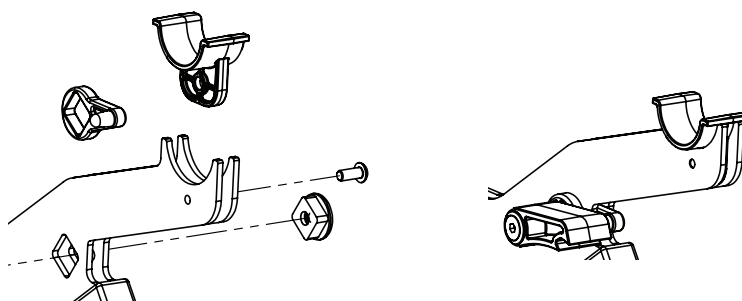
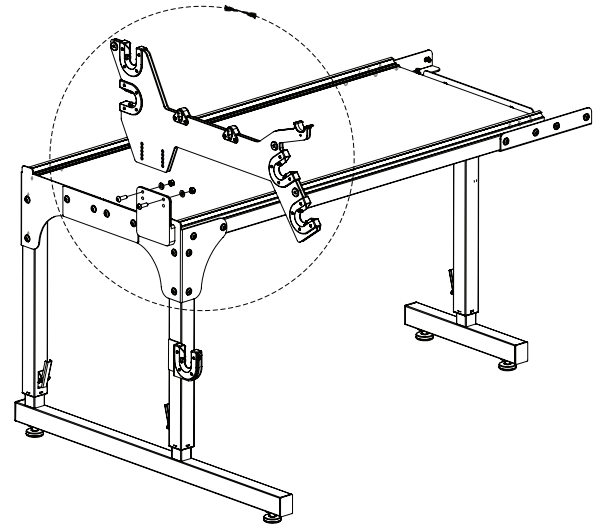
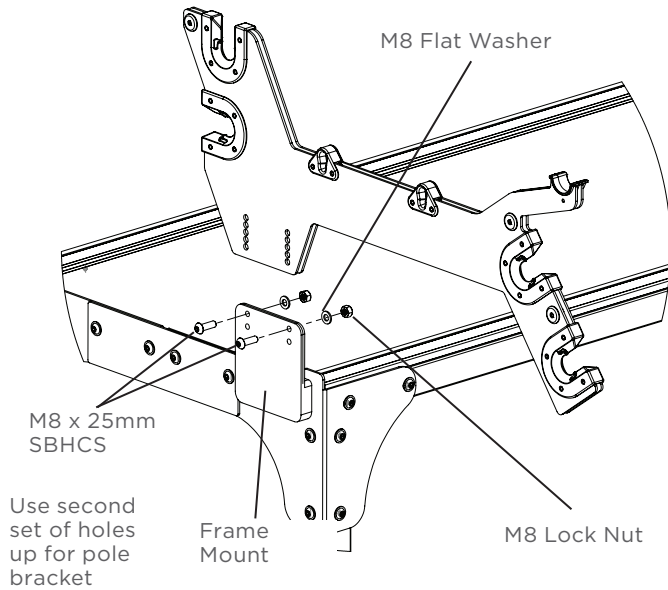

Fig. 6-4

Left Side Option

If assembling with the hand wheel and ratchets on the left side, remember that the ratchet stops and the ratchet stop holder nubs go to the inside of the pole bracket when it is attached to the table (Note: Logo will be on inside for this orientation). Keeping this in mind, follow **Steps 6-2** through **6-5** to assemble the left pole bracket, reversing the direction of the ratchet stop, ratchet stop bushing, ratchet stop holder and ratchet-stop mount shown in Fig. 6-2.

Step 7 Pole Bracket Assembly



Note: If setting frame up with hand wheel on the left side of frame, reverse position (switch sides) of pole brackets.

Step 7: Pole Bracket Assembly

Parts needed

- 1- Table
- 1- Open-hole Pole Bracket w/Ratchet Stops Assembly
- 1- Plugged-hole Pole Bracket
- 4- M8 x 25mm SBHCS
- 4- M8 Flat Washer
- 4- M8 Lock Nut

Tools Required

- 13/17 mm Wrench (Provided)
- 5mm Allen Wrench (Provided)

7-1: Slide the plugged-hole pole bracket down over the metal frame mount on the left frame side front. The pole bracket should straddle the frame mount. Attach the plugged-hole pole bracket to the frame using two (2) M8 x 25mm SBHCS. Thread the screws through the second hole from the bottom of the pole bracket from the outside to the inside of the frame. On the end of each screw, slide a flat washer followed by a lock nut, as shown in Fig. 7-1.

7-2: Visually level the pole bracket assembly and fully tighten the two screws with 13/17 mm wrench & 5mm Allen wrench provided.

7-3: Repeat **Step 7-1** & **Step 7-2** to attach the open-hole pole bracket w/ratchet stops assembly, making sure the ratchet stops are on the inside of the frame.

Step 8 Pole Assembly



Important:

Be careful when assembling poles to not pinch your hands between pole parts while sliding them together.



Note:

Your frame comes with 15 pole sections, which enable you to create 5 completed pole assemblies (the 4-foot size uses five pole sections, 8-foot uses 10 pole sections and 5 couplers, and the 12-foot uses all 15 pole sections and all 10 couplers).



Note:

If you are assembling a four foot (4') frame, you may skip Step 8 and proceed to Step 9.

Step 8: Pole Coupler Assembly

Parts needed

15 Pole sections

10 Pole couplers

Note: Instructions below are for assembling 12' pole assemblies using three 4-foot pole sections for each of five poles. See alternate instructions for different size frames below:

4-foot frame: Skip **Step 8** and proceed to **Step 9**.

8-foot frame: Use two 4-foot pole sections for each of five poles.

8-1: Join two 4-foot pole sections together by inserting a pole coupler into the end of one pole section as shown in Fig. 8-1, depressing the spring button as it slides in. Continue sliding until the spring button pops out of the hole in the pole section. Repeat to add second 4-foot pole section to the first.

8-2: In same manner, add final 4-foot pole section to section completed in **Step 8-1** to complete one 12-foot pole assembly.

8-3: Using remaining couplers and pole sections, repeat steps 8-1 and 8-2 to complete four more 12-foot pole assemblies for a total of 5 pole assemblies.

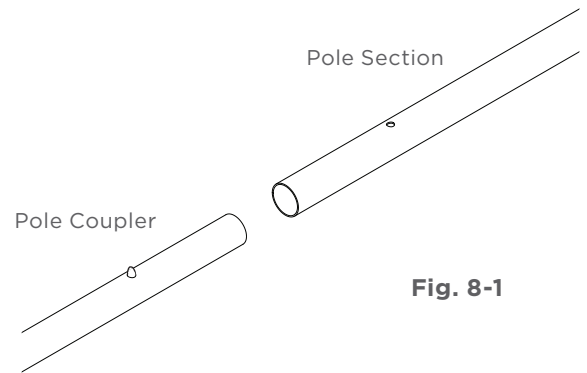
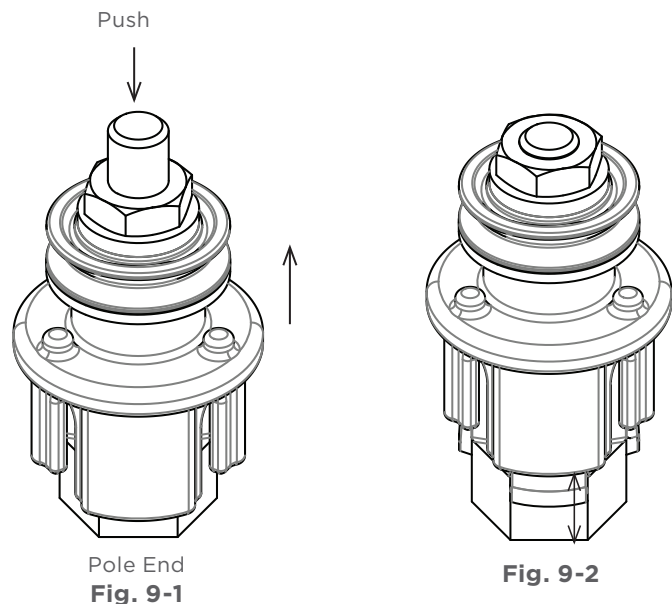

Fig. 8-1

Step 9 Adding the Pole Ends



Step 9: Pole End Assembly

Parts needed

- 5- Pole Assemblies
- 7- Pole Ends
- 2- Short-Bolt Ratchet Wheel Assemblies
- 1- Long-Bolt Ratchet Wheel Assembly
- 1- Hand Wheel

Tools Required

- 13/17 mm Wrench (Provided)

Pole End Assembly

9-1: Check one pole end to ensure that it matches Figs. 9-1 and 9-3.

9-2: Loosen the nut on the pole end until it nearly reaches the end of the bolt.

9-3: Holding onto the outside pole end, push the nut end of the bolt towards the opposite end of the assembly, until the inside pole end short bolt wedge slides out (Fig. 9-2). This makes the outside diameter of the pole end narrower and ready to be inserted into the end of the pole assembly.

9-4: Repeat Steps 9-1 through 9-3 to prepare the remaining 6 pole ends for insertion.

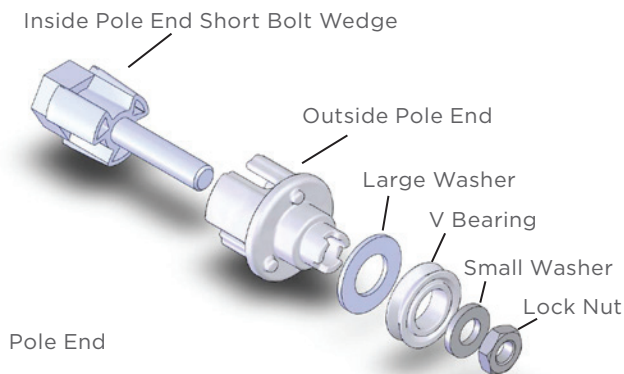

Fig. 9-3

Pole End assembly comes pre-assembled. Exploded diagram is for reference only.

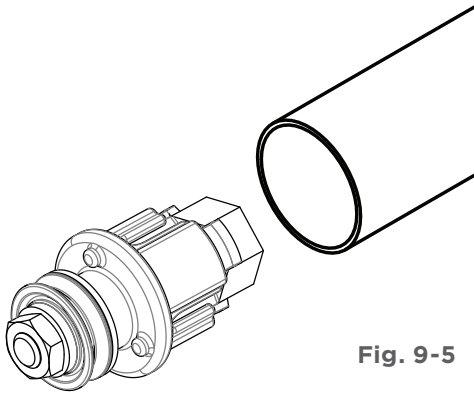

Fig. 9-5

9-5: Slide one pole end into the end of one 12-foot pole assembly, as shown in Fig. 9-5. Check that the pole end is inserted completely into the pole assembly.

9-6: Completely tighten the nut, using the 13/17mm wrench, while holding the pole end assembly tightly into the open end of the pole. This will expand the outer pole end, ensuring a tight fit in the pole.

Note: A regular nut is provided as an assembly aid tool if you have difficulty holding the pole end assembly while tightening.

9-7: Repeat steps 9-5 and 9-6 to add one pole end to the remaining four 12-foot pole assemblies.

9-8: Repeat steps 9-5 and 9-6 to add remaining two pole ends to the open ends of two 12-foot pole assemblies (see bottom pole in Fig. 9-8).

Set these two completed poles aside for use as the batting storage pole and the idler pole.

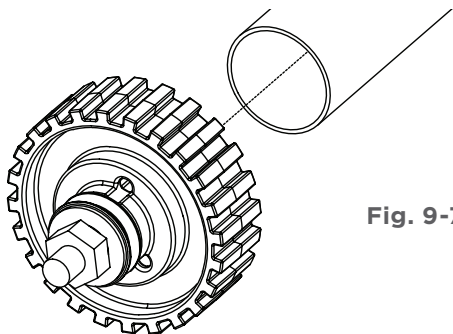

Fig. 9-7

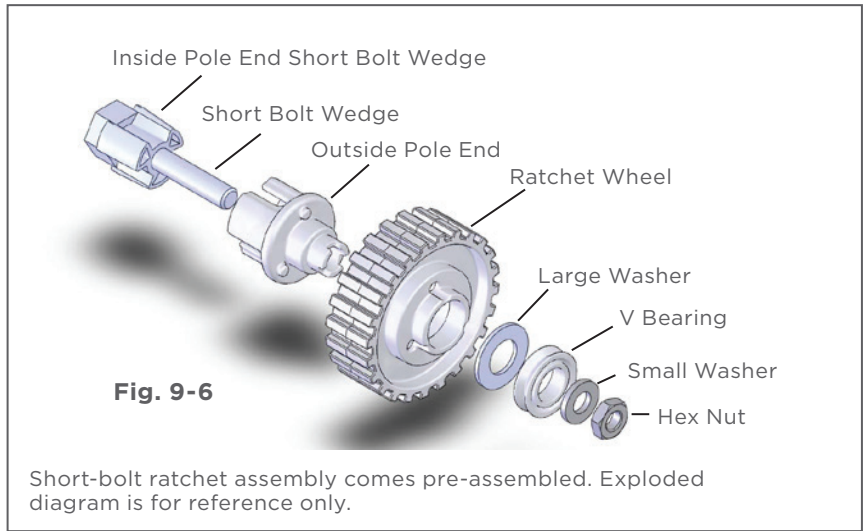

Fig. 9-6
Short-bolt ratchet assembly comes pre-assembled. Exploded diagram is for reference only.

Short-Bolt Ratchet-Wheel Assembly

9-9: Check the short-bolt ratchet-wheel assembly to ensure that it matches Fig. 9-6.

9-10: Loosen the nut at the end of the short-bolt ratchet-wheel assembly until it nearly reaches the end of the bolt.

9-11: Holding onto the outside pole end, push the nut end of the bolt towards the opposite end of the assembly until the inside pole-end short-bolt wedge slides out (in similar fashion to **Step 9-3**). This makes the outside diameter of the outside pole end narrower and ready to be inserted into the end of a pole assembly.

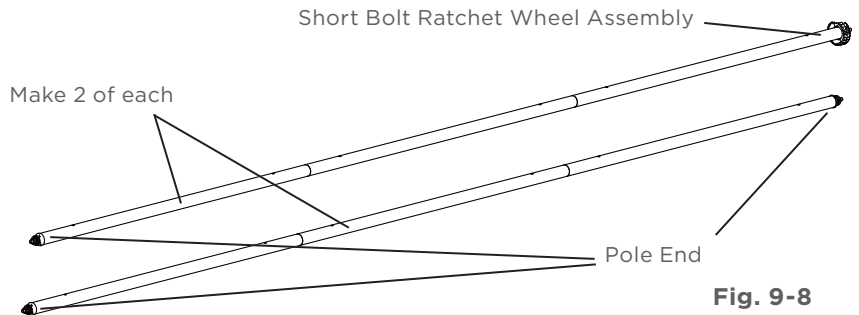
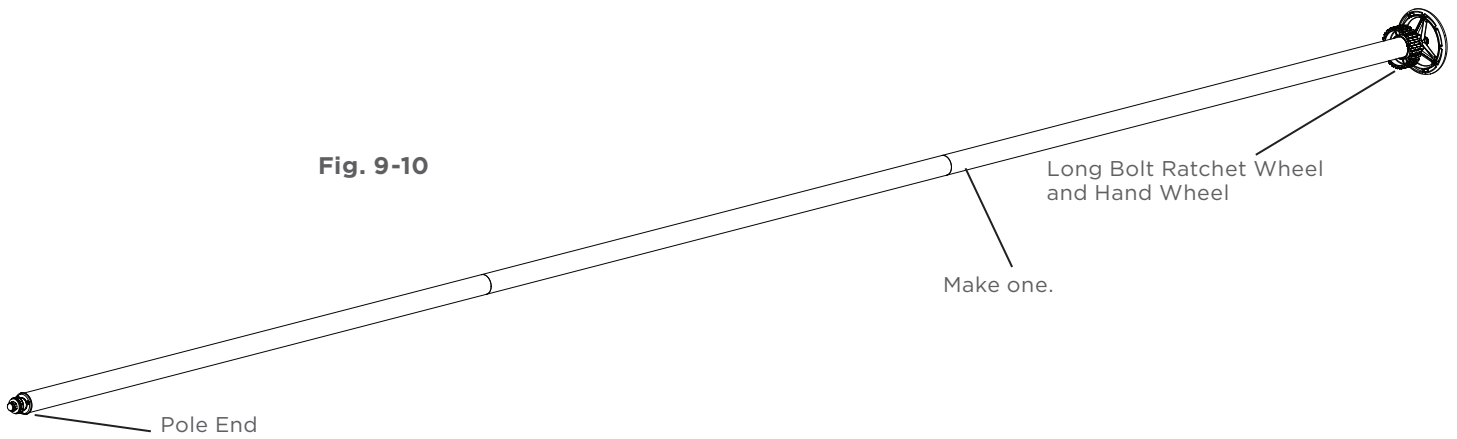

Fig. 9-8



Long Bolt Ratchet Wheel and Hand Wheel Assembly

9-12: Check the long-bolt ratchet-wheel assembly to ensure that it matches Fig. 9-9.

9-13: Add the hand wheel assembly to the long-bolt ratchet-wheel assembly as shown in Fig. 9-9, aligning the three tabs on the hand-wheel insert with the three notches on the outside pole end. If the three tabs are not properly aligned, the hand wheel will spin freely, independent of the pole. The goal is to have the three tabs engaged, so turning the hand wheel will turn the pole.

9-14: Repeat step 9-11 to prepare the long-bolt ratchet wheel and hand wheel assembly for insertion.

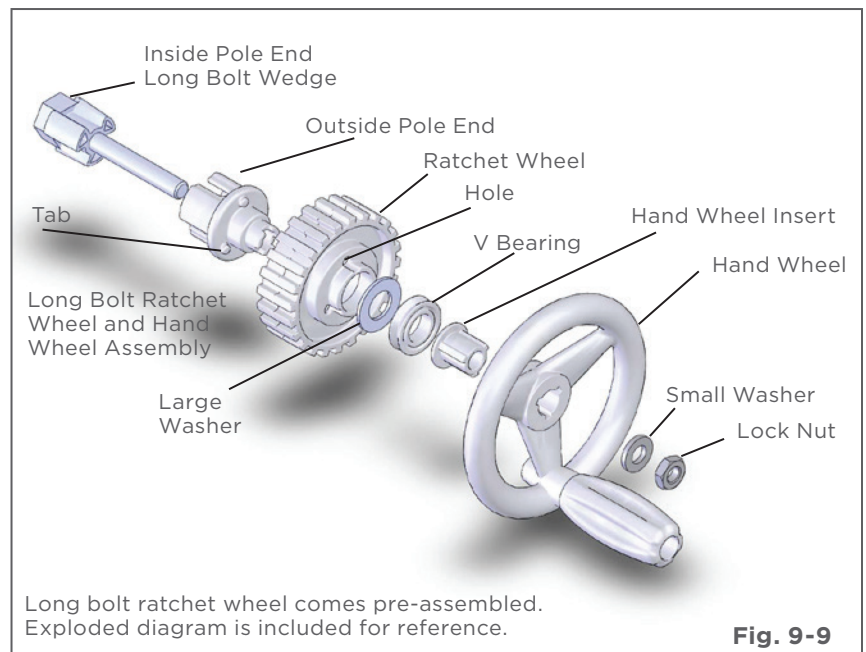

Ratchet Wheel and Hand Wheel Insertion

9-15: Insert one short-bolt ratchet wheel assembly into the open end of a pole assembly as shown in Fig. 9-7 on page 19. Check that the pole end is inserted completely into the pole assembly.

9-16: Completely tighten the nut, using the 13/17 mm wrench, while holding the short-bolt ratchet-wheel assembly tightly into the open end of the pole. This will expand the outer pole end, ensuring a tight fit in the pole. Make sure the 3 tabs on the outside pole end, align with the 3 holes in the ratchet wheel, see Fig 9-9. This completes the backing pole.

9-17: Repeat steps 9-15 and 9-16 to complete the quilt-top pole. Set both poles aside.

9-18: In same manner, slide the long-bolt ratchet wheel and hand wheel assembly into the open end of the remaining pole assembly and while holding the completed assembly tightly into the open end of the pole tighten the nut, using the 13/17 mm wrench. Check to be sure the hand wheel engages the ratchet wheel assembly and does not spin loosely and that the 3 tabs of the outside pole end align with the 3 holes in the ratchet wheel. This completes the take-up pole.

Steps 10 & 11

Pole to Frame Assembly

Rubber End Cap Assembly



Note: The poles will snap past the plastic fingers, which are shown in Fig. 10-2.

Plastic Fingers

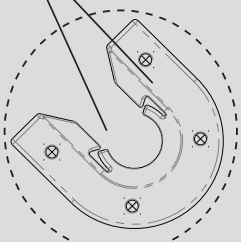

Fig. 10-2

Step 10: Pole to Frame Assembly

Parts needed

- 1- Frame Assembly
- 1- Batting Storage Pole
- 1- Idler Pole
- 1- Quilt Top Pole
- 1- Backing Pole
- 1- Take-up Pole

10-1: Place the poles on the frame, as shown in Fig. 10-1.

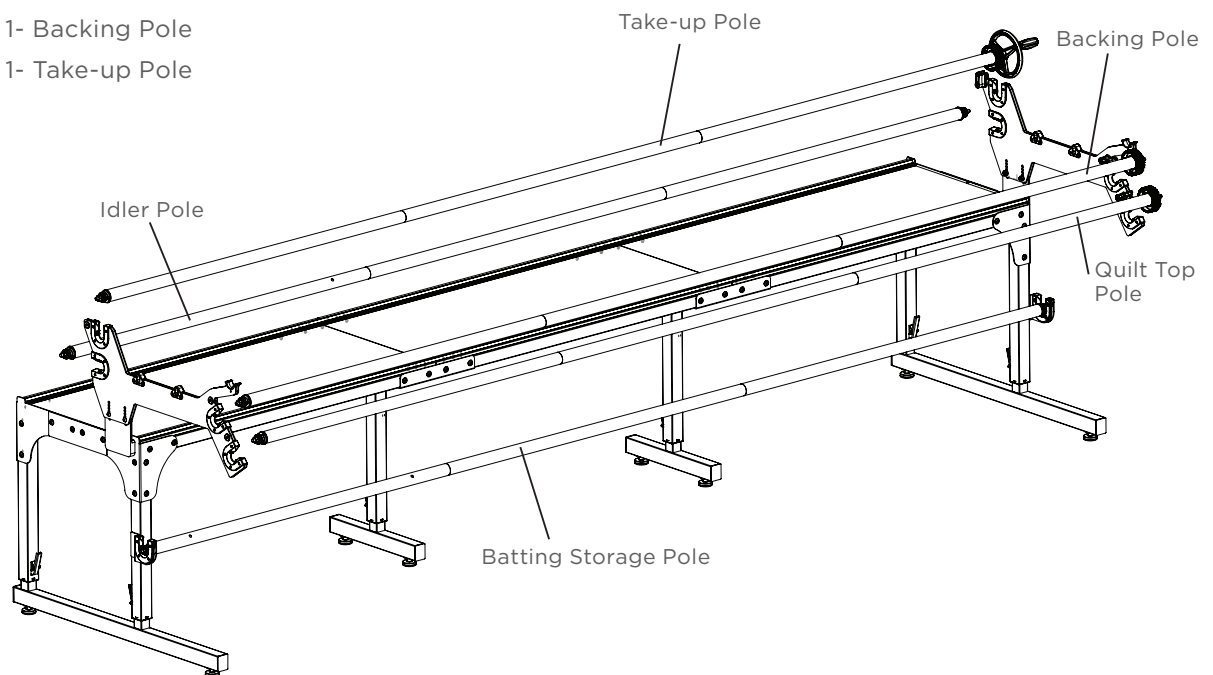

Fig. 10-1

Step 11: Rubber End Cap Assembly

Parts needed

- 1- Frame Assembly
- 10- Rubber End Caps

11-1: Slide one (1) rubber end cap onto the end of each bolt sticking out of the pole ends, as shown in Fig. 11-1. If the poles are assembled properly there should be approximately $3/8$ "- $1/2$ " of metal threads showing beyond the ends of each pole.

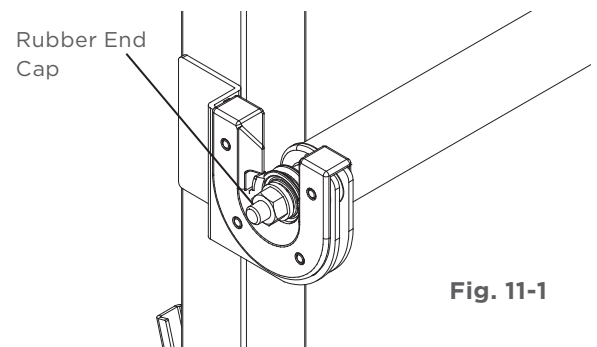

Fig. 11-1

Steps 12 & 13

Optional Hook and Loop Attachment Bungee Clamp Assembly



Note: Janome has provided the hook and loop strips for use with clamps that have hook and loop-style straps. Only Bungee-style clamps have been provided with the Quilt Maker Pro 12' Quilting Frame, but these strips have been provided for use with other types of clamps.

Step 12: Optional Hook and Loop Attachment Assembly

Parts needed

- 1- Frame Assembly
- 2- Hook and loop Strip

12-1: Start from one side of the hook and loop strip and remove about 1/2 of the protective paper and then place the sticky side right below the bungee clamps and press the hook and loop strip firmly to the frame. Remove the remainder of the protective paper and press the hook and loop strip down. (Fig. 12-1)

12-2: Follow **Step 12-1** for the other remaining strip.

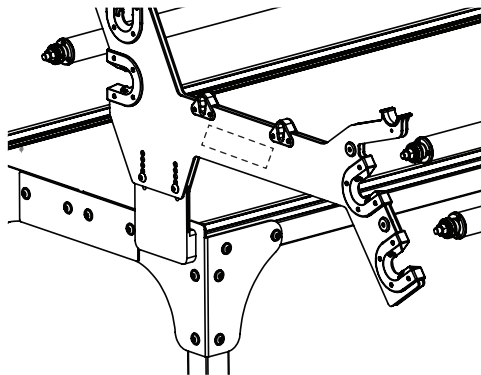

Fig. 12-1

Step 13: Bungee Clamp Assembly

Parts needed

- 1- Frame Assembly
- 4- Bungee Clamps

13-1: Thread the bungee cord from the inside of the frame through the bungee slot and then pull the cord in a downward movement to lock the bungee clamp in place. (Fig. 13-1)

13-2: Follow **Step 13-1** for the other three bungee clamps.

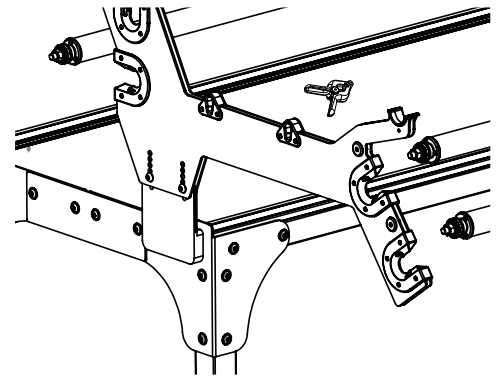

Fig. 13-1

Steps 14 & 15

Hook and Loop on Pole Assemblies

Attach Leaders

Step 14: Hook and Loop on Pole Assemblies

Parts needed

- 1- Quilt Top Pole
- 1- Backing Pole
- 1- Take-up Pole
- 3- 11.5 foot Hook and Loop Strips

Tools Required

- Measuring tape or Ruler (Not Provided)
- Scissors (Not Provided)

14-1: Prepare to attach the hook and loop strip to the quilt top pole, backing pole, and take-up pole (see Fig. 10-1), by measuring in 3" from each end of the pole. Peel the backing off the strip as you go and apply to all three poles, starting at the 3" mark and ending at the opposite 3" mark.

Take care to stick the hook and loop on straight. This step will determine how well your quilts load in the future. Use the Spring Coupler Snap Buttons as a guide when aligning the hook and loop strip for best results. (Note: Attach the strip next to the snap button, not between.)

Once the hook and loop strip has been adhered from one end of the poles to the other, it can be clipped where the poles meet at each pole coupler.

Step 15: Attach Leaders

Parts needed

- 1- Frame Assembly with Hook and Loop strip applied to Poles
- 3 - QMP Leaders

15-1: Mark the center of the leaders on both the hook and loop strip and the hemmed edge. Mark the center of the quilt top pole, backing pole and take-up pole with a permanent marker.

15-2: Beginning in the center, align the marks and attach the leaders to the hook and loop strip on backing pole and the quilt top pole so the marked sides of the leaders hang to the center between the poles.

Beginning in the center, align the marks and attach the remaining leader so it falls to the back of the take-up pole.



NOTE: The leaders provided with the Quilt Maker Pro 12' Quilting Frame are sized for the 12' frame. If you are setting the frame up permanently at the 8' or 4' length, you may cut the leaders to fit.

Step 16

Adjusting Quilt Maker Pro 12' Quilting Frame Height



Note: It is easier to raise the frame height than to lower the frame, because the legs will ratchet up when lifted. To lower the frame, a second person will be needed to release the two latches on each leg while the other lifts the frame. This is why the frame was assembled at the lowest height setting.

Step 16: Adjusting Frame

16-1: The frame can be all the way down with no slots showing on the legs or raised in increments up to where nine sets of slots are showing. Most quilters will have three to six sets of slots showing when the height is set comfortably for them.

16-2: Adjust the frame height so that when standing at the front of the machine with your hands on the front handle bars, your elbows are bent at a 90 degree angle. It is recommended that you raise the frame one or two slots at a time until you reach your desired height setting as described in **Steps 16-3** and **16-4**.

16-3: Place a foot on the side leg bottom tube and lift the end of the frame up until the latches click once or twice, making sure both latches are fully engaged and in the same height slot. The end of the latch levers will be about 1.5" away from the leg when engaged properly and much closer if not fully engaged.

16-4: Repeat **Step 16-3** on the other end of the frame and then lower the two middle legs to the same slot, ensuring that the latches are fully engaged into the same slot on both side legs and the two middle legs. You may need a second person to lift the middle of the table to engage the latches fully on the middle legs.

16-5: Finally double-check to make sure the frame is level. The slots on the legs are for rough height adjustment and the levelers on each leg are for fine height adjustment and leveling of the frame. See **Step 4-10**, if needed, for leveling review.

16-6: Your Quilt Maker Pro 12' Quilting Frame is now complete.

Loading the Frame & Using the Pole Cradles

Loading The Quilt Frame

First, identify the rails on the frame. There will be two rails in the rear of the frame – these are the Idler Pole and Take-up Pole. The top rail (Idler Pole) will have the shortest leader attached to it so that you can pin the top of your backing fabric to it. The rail underneath (Take-up Pole) it is there to help hold the quilt tight while it is being quilted. It will not have anything pinned to it. The backing will be coming off the rail from under the rail. You will not be able to see it once the fabric is loaded because the batting and quilt top are on top but it is rolling on that rail over and the under it.

There are two rails that are in the front of the frame, Backing Pole and Quilt Top Pole. Both of these rails need to have leaders attached to them (it doesn't matter which two of the leaders you decide to attach). The rail that is on top (Backing Pole) is the rail you will pin the backing to. Next, lay your batting down and your quilt top. You will gently take the bottom of the quilt top and pin it to the lower rail (Quilt Top Pole) that you have a leader attached to. You will need to pin the quilt top to the lower rail. See the picture below for reference. Notice that the quilt top is rolled on the rail, first going over and then under the rail.

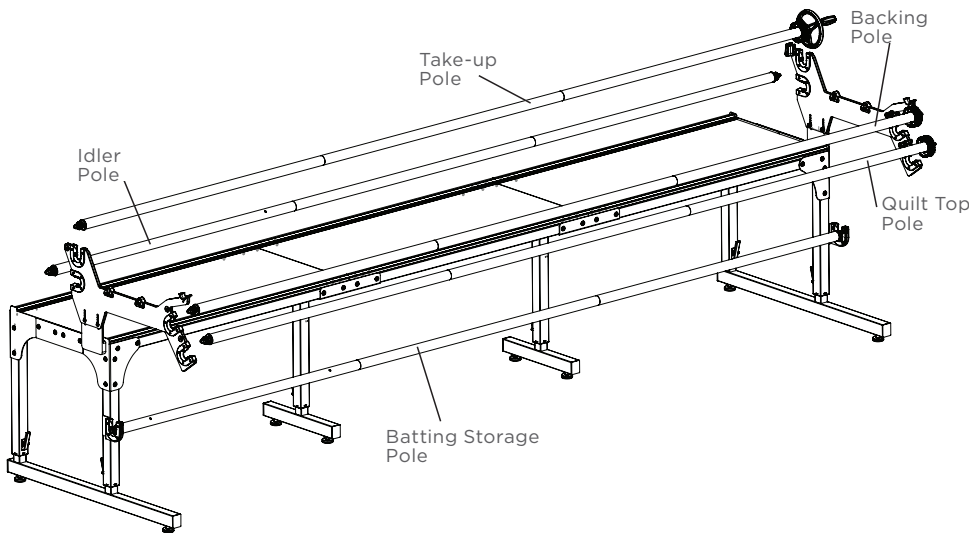

To use the Janome Pole Cradles when loading the quilt and quilt batting

1. After loading the quilt backing and the quilt top, release the ratchets on the quilt-top pole.
2. Pull one side of the quilt-top pole out of the pole bearing and lay it in the corresponding Pole Cradle. Repeat on the other side of the quilt frame.
3. Lay the quilt batting on the quilt backing, align it with the top of the backing, and smooth it in place.
4. Unroll enough of the quilt top to reach the top of the quilt backing and batting.

5. Return both sides of the quilt-top pole to the pole bearings and put the ratchets back in place.
6. Proceed with attaching the clamps, stitching the plumb line, aligning the quilt top with the plumb line, and basting the top edge and sides of the quilt top.

To use the Janome Pole Cradles when advancing the quilt

1. When you're ready to advance your quilt, release the ratchets on the poles. Advance the quilt.
2. Pull one side of the quilt-top pole out of the pole bearing and lay it

in the corresponding Pole Cradle. Repeat on the other side of the quilt frame.

3. Reach under the quilt top to smooth and straighten the quilt batting.
4. Return both sides of the quilt-top pole to the pole bearings and put the ratchets back in place.
5. Proceed with attaching the clamps, smoothing and tensioning the quilt top, and basting down the sides of the quilt.

