

SERVICE MANUAL

MODEL: MC9400QCP

INDEX

Replacing External Parts

Face cover.....	1
Thread cutter cover	1
Base plate.....	2
Bed cover	3
Front cover	4
Rear cover.....	5
Carriage cover.....	6
Belt cover.....	6

Mechanical Adjustment

Needle drop position.....	7
Hook timing.....	8
Needle bar height.....	9
Clearance between the needle and hook.....	10
Backlash between the rotary hook gear and lower shaft gear.....	11
Upper shaft shield position	12-13
Needle thread tension	14
Tension release mechanism.....	15
Height of the embroidery foot	17
Presser foot lifter detecting switch.....	20
Automatic thread cutter	21
Remaining bobbin thread sensor.....	22
Hoop position.....	23
X-sensor position.....	25
Y-sensor position	26
Y-carriage supporter	27
DC Motor belt deflection	29

Replacement

Needle threader.....	16
Printed circuit board A.....	18
Printed circuit board F	19
Carriage unit.....	24
Switching power supply	28
Driving motor	29
Replacing the Gear of the X-carriage	30

Oiling

Needle bar, presser bar and thread take-up lever	31
Oil wick	32
Lower shaft supporter (front and rear).....	32
Y-carriage	33
X-carriage.....	33

PARTS LIST	34-71
-------------------------	--------------

Changing External Parts

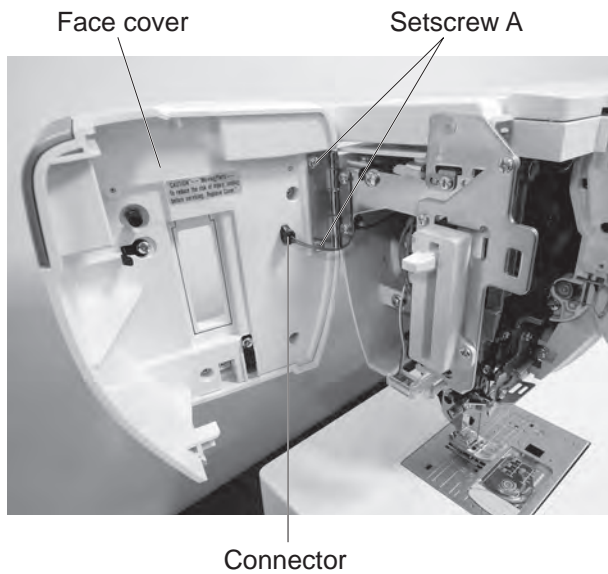

Face cover

To remove:

1. Open the face cover.
Disconnect the connector from the face cover.
Remove the setscrews A.
Remove the face cover.

To attach:

1. Follow the above procedure in reverse.



Top cover

To remove:

1. Raise the carrying handle.
Remove the setscrew B.
Close the carrying handle.



2. Open the top cover.

Remove the setscrews C and D.

3. Raise the carrying handle and remove the top cover.

To attach:

1. Follow the above procedure in reverse.

Changing External Parts



Belt cover

To remove:

1. Remove the caps from the belt cover.
Remove the setscrews A and B.



2. Loosen the setscrew C.



3. Loosen the setscrew D.
Remove the belt cover.

To attach:

1. Follow the above procedure in reverse.

Changing External Parts

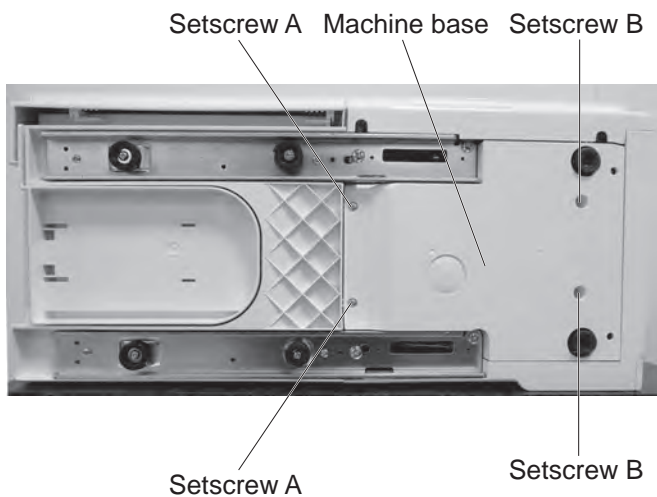

Machine base

To remove:

1. Remove the setscrews A and B .
2. Remove the machne base.

To attach:

1. Follow the above procedure in reverse.

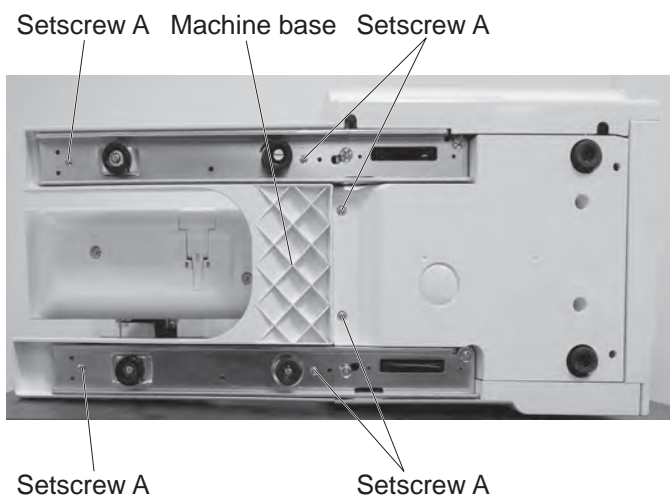

Base cover

To remove:

1. Remove the extension table.
Remove the setscrews A.
2. Remove the base cover.

To attach:

1. Follow the above procedure in reverse.

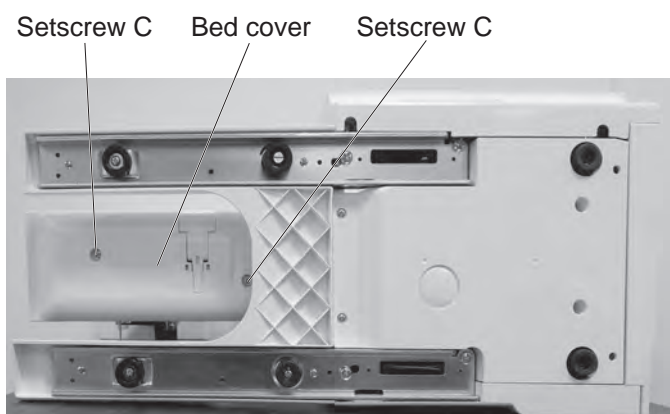

Bed cover

To remove:

1. Remove the extension table.
Remove the setscrews C.
2. Remove the bed cover.

To attach:

1. Follow the above procedure in reverse.

Changing External Parts

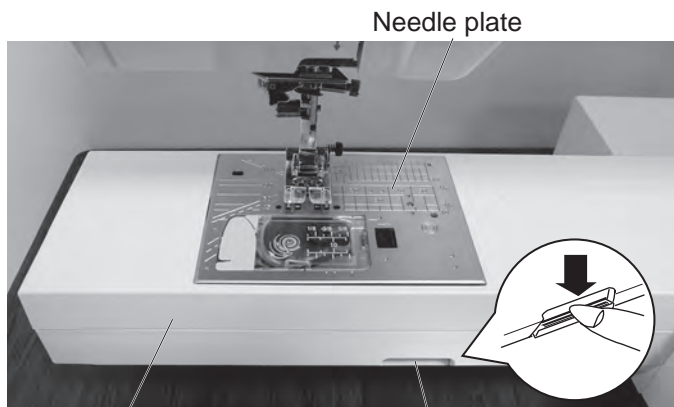

Free arm cover

To remove:

1. Remove the machine base and base cover (see page 3).
Press the needle plate release lever to remove the needle plate.



2. Remove the pin.
Remove the bed cover (see page 3).

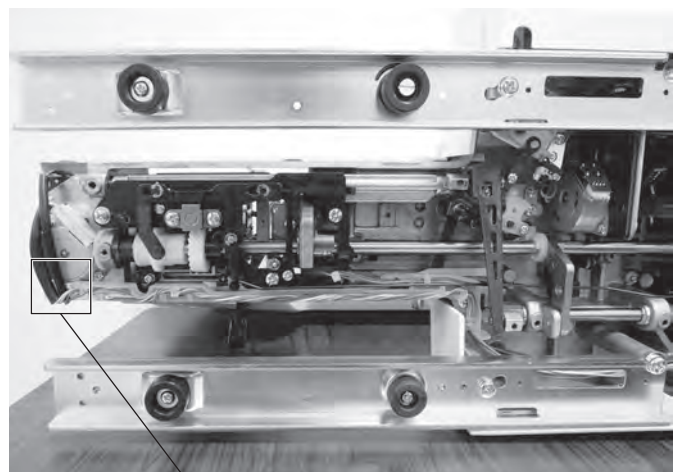

3. Loosen the setscrew A.

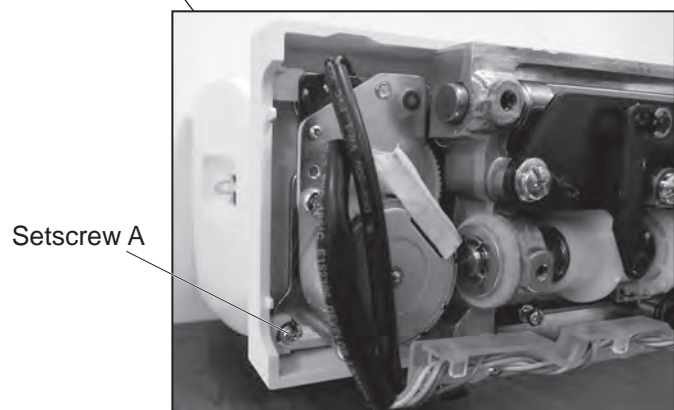

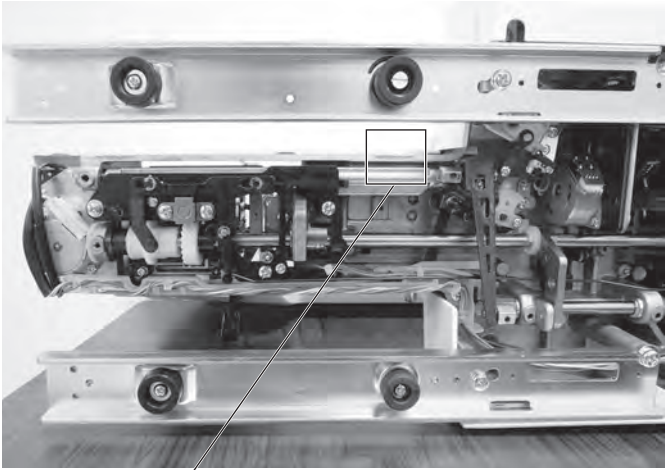

4. Remove the free arm cover from the free arm while unlocking the hook A (front side of the free arm) and B (inside of the machine base) from the free arm.

5. Slide the free arm cover to the left.
Remove the free arm cover.

To attach:

1. Follow the above procedure in reverse.

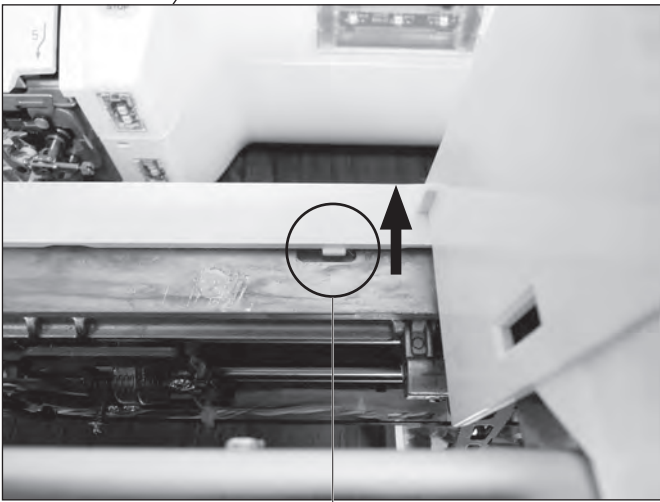

Hook A

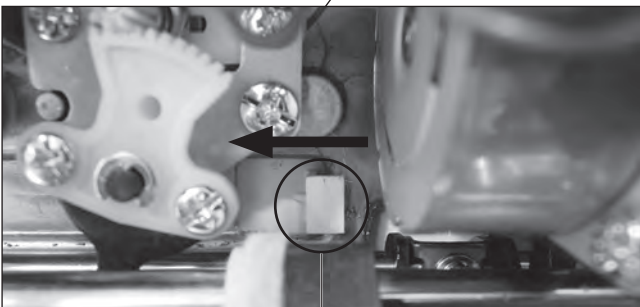
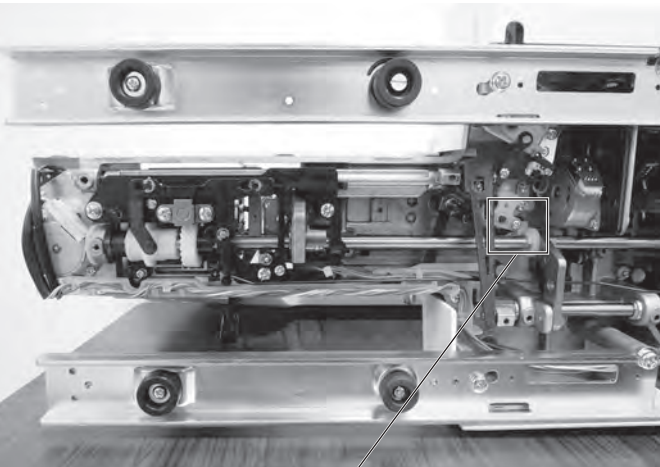

Hook B

Changing External Parts

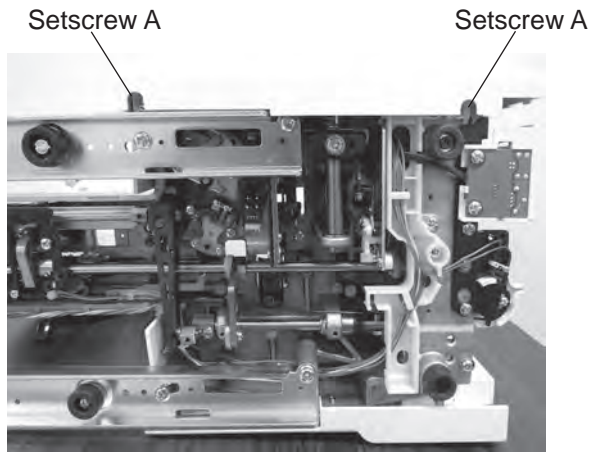

(Bottom of the machine)

Front cover

To remove:

1. Remove the top cover, belt cover, base cover, machine base and free arm cover (see pages 1-5).
2. Loosen the setscrews A .

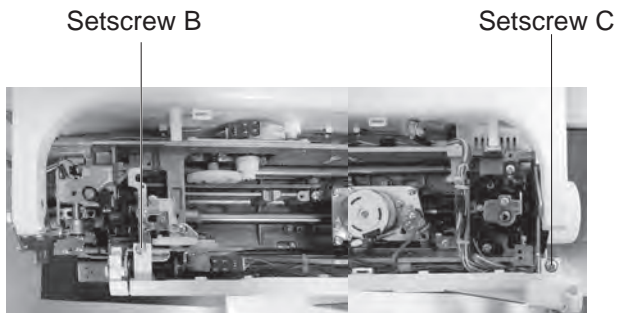

(Top of the machine)

3. Loosen the setscrews B and C.

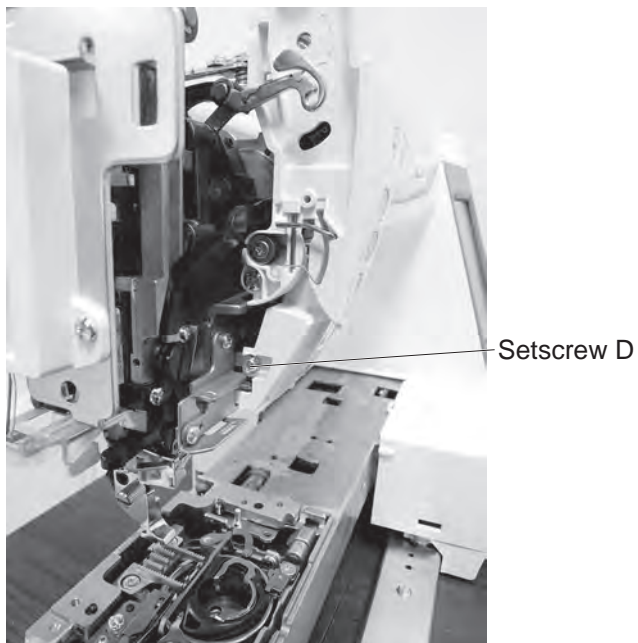

4. Loosen the setscrew D.

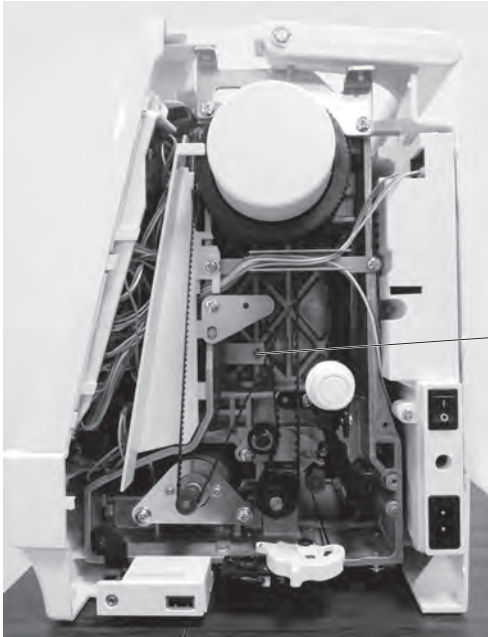

5. Loosen the setscrew E.

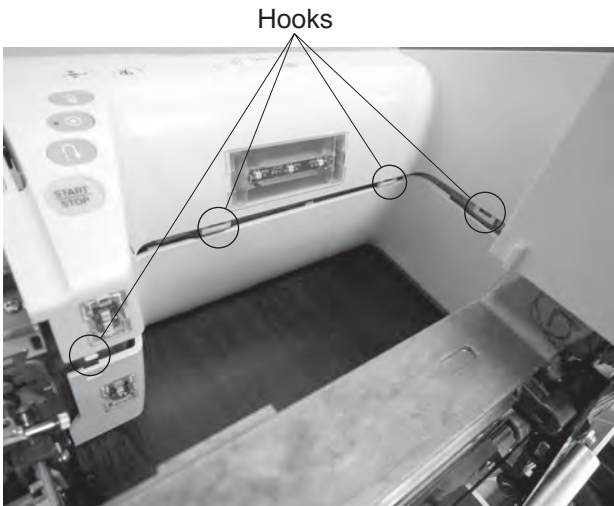

6. Unlock the hooks from the front cover.
Remove the connectors from the circuit board A.
Remove the front cover.

To attach:

1. Follow the above procedure in reverse.
Refer to page 7 for locating connector posts.

Changing External Parts

Face cover

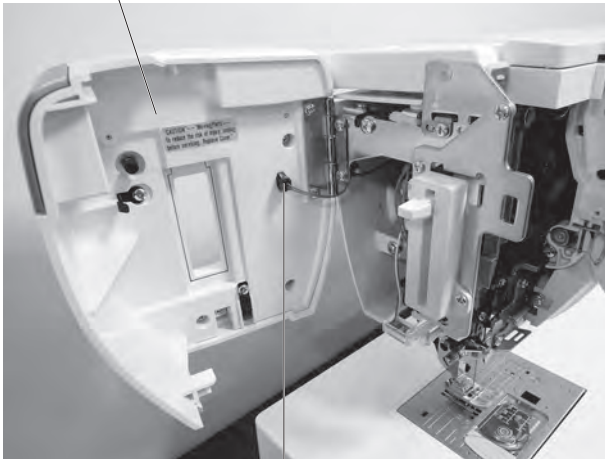

Connector A

Rear cover

To remove:

1. Remove the top cover, machine base, base cover and free-arm cover (see pages 1, 3 and 4-5.)
2. Open the face cover.
Disconnect the connector from the face cover.
Close the face cover.

Setscrew A



3. Loosen the setscrew A.

Setscrew B

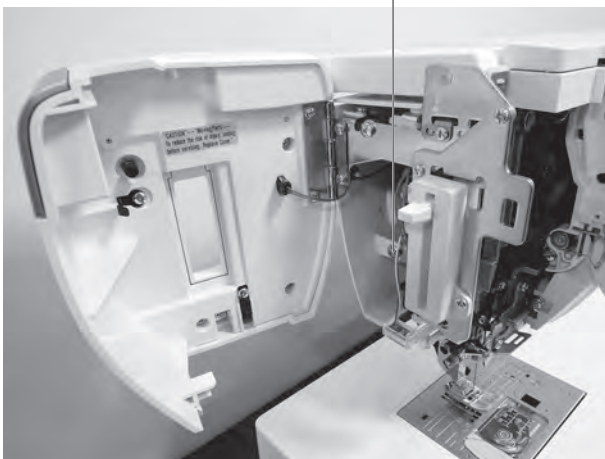

4. Loosen the setscrew B.

Setscrews C



Setscrews D

5. Remove the setscrews C and D.
Unlock the rear cover hook from the front cover.

Connector A

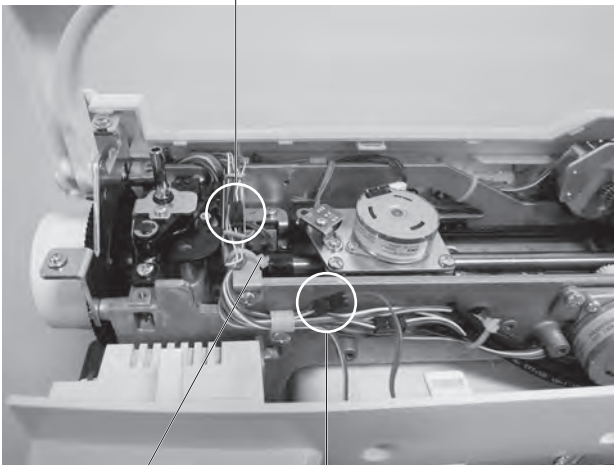

Cord tie

Connector B

6. Disconnect the connectors A and B from the sockets.
Cut and remove the cord tie as necessary.
Remove the rear cover.

To attach:

1. Follow the above procedure in reverse.

Replacing Electronic Components

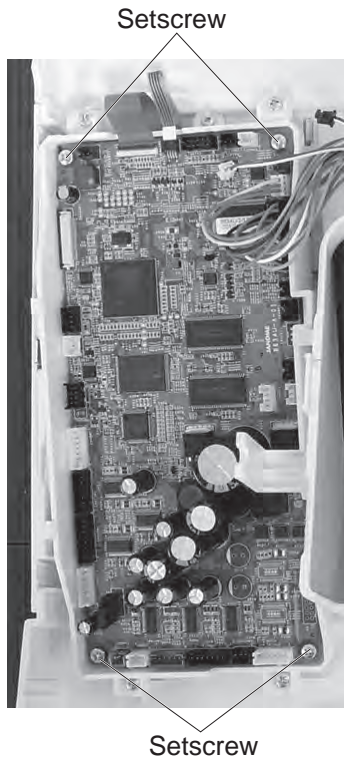

Printed circuit board A

NOTE:

Do not disconnect the connectors by pulling on cord.
To disconnect the connectors, grasp the connector, not the cord.

To remove:

1. Remove the front cover.
2. Grasp the connector directly with your fingers and pull.
Do not pull the lead wire, as this may damage the contact sleeve inside the connector.
Remove the setscrews and printed circuit board A.

To attach:

1. Follow the above procedure in reverse.
Be sure that the connector post on the printed circuit board to which it is connected.
Position the connector correctly, then push it straight down until it locks in place.

Printed circuit board A connection

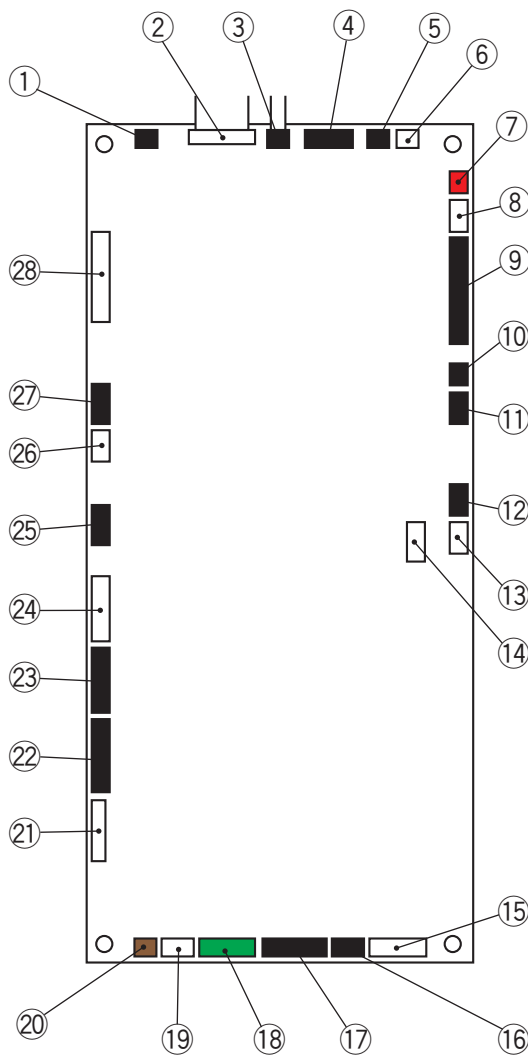

- ① Bobbin winder switch
- ② LCD
- ③ Touch panel
- ④ Program (Slave)
- ⑤ Printed circuit board L1*
- ⑥ Printed circuit board L2
- ⑦ Printed circuit board L3 (red)
- ⑧ Slide volume
- ⑨ Printed circuit board F
- ⑩ Presser foot lifter sensor*
- ⑪ BH sensor*
- ⑫ Upper thread sensor*
- ⑬ Knee lifter sensor
- ⑭ Power switch
- ⑮ Thread cutter motor
- ⑯ Remaining bobbin thread detecting sensor
- ⑰ Feed motor
- ⑱ Remaining bobbin thread detecting motor (green)
- ⑲ Needle plate detecting sensor
- ⑳ Drop feed detecting sensor (brown)
- ㉑ DC motor
- ㉒ Presser foot lifter motor
- ㉓ Thread tension motor
- ㉔ Zigzag motor
- ㉕ USB
- ㉖ Foot control & Thread cutter switch jack
- ㉗ Phase sensor
- ㉘ Program (Slave)

Connect the connectors to the corresponding connector posts on the circuit board A (see page 10).

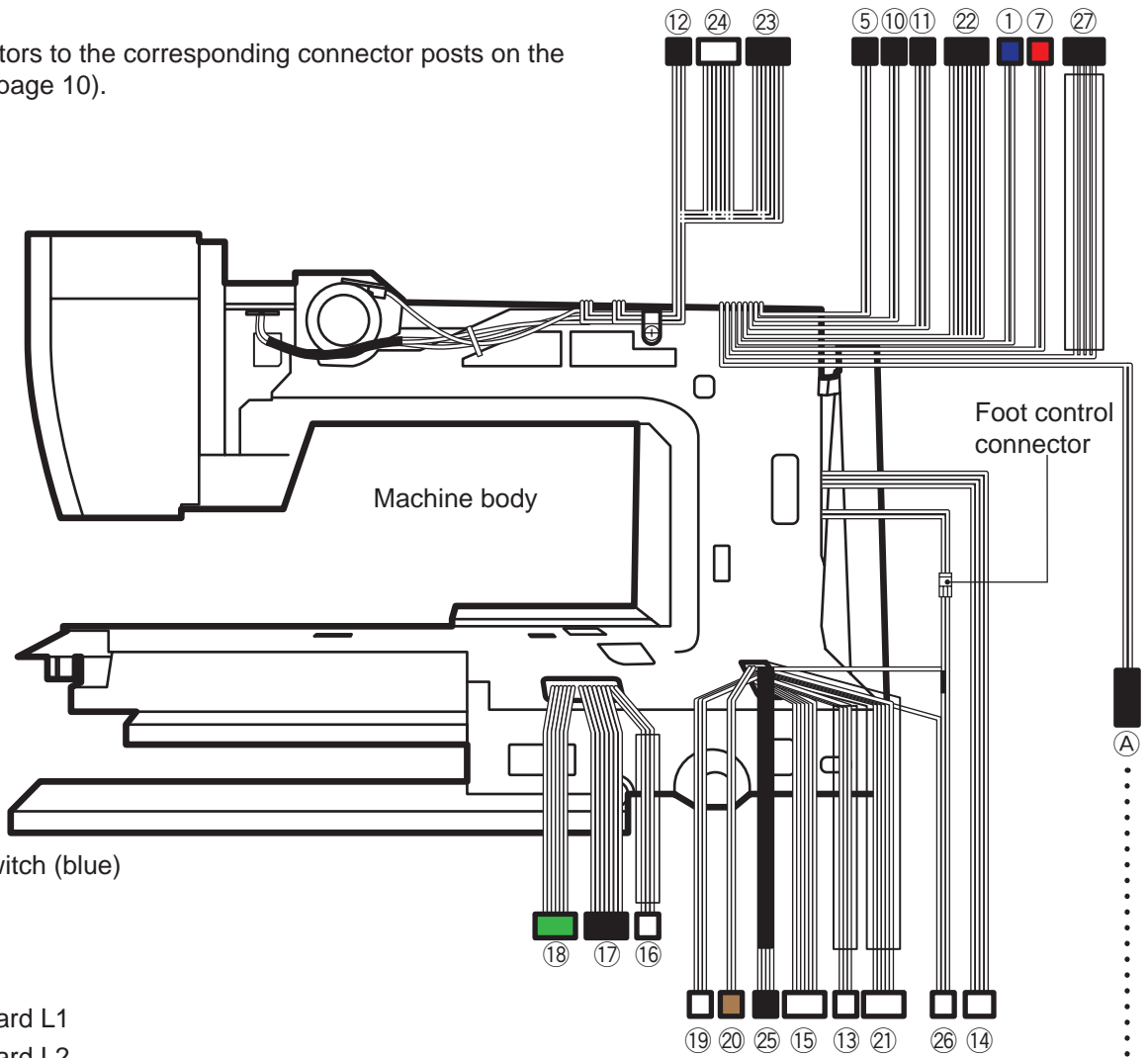

- ① Bobbin winder switch (blue)
- ② LCD
- ③ Touch panel
- ④ Program (Slave)
- ⑤ Printed circuit board L1
- ⑥ Printed circuit board L2
- ⑦ Printed circuit board L3 (red)
- ⑧ Slide volume
- ⑨ Printed circuit board F
- ⑩ Presser foot lifter sensor
- ⑪ BH sensor
- ⑫ Upper thread sensor
- ⑬ Knee lifter sensor
- ⑭ Power switch
- ⑮ Thread cutter motor
- ⑯ Remaining bobbin thread detecting sensor
- ⑰ Feed motor
- ⑱ Remaining bobbin thread detecting motor (green)
- ⑲ Needle plate detecting sensor
- ⑳ Drop feed detecting sensor (brown)
- ㉑ DC motor
- ㉒ Presser foot lifter motor
- ㉓ Thread tension motor
- ㉔ Zigzag motor
- ㉕ USB
- ㉖ Foot control & Thread cutter switch jack
- ㉗ Phase sensor
- ㉘ Program (Slave)
- A Lamp relay cable

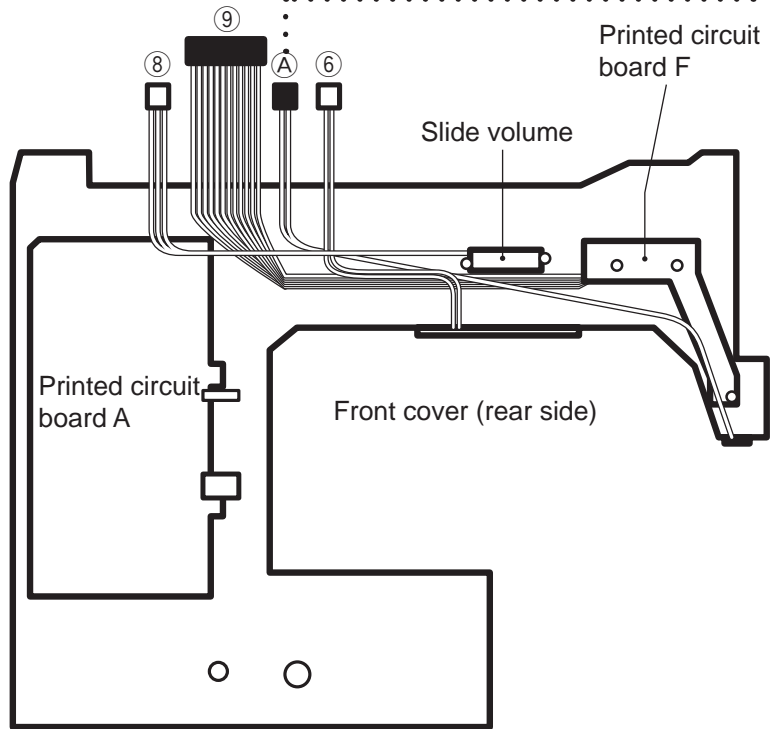

* Connectors ⑤ and ⑩, ⑪ and ⑫ are very similar. Be sure to position the connector to the correct place.

Replacing Electronic Components

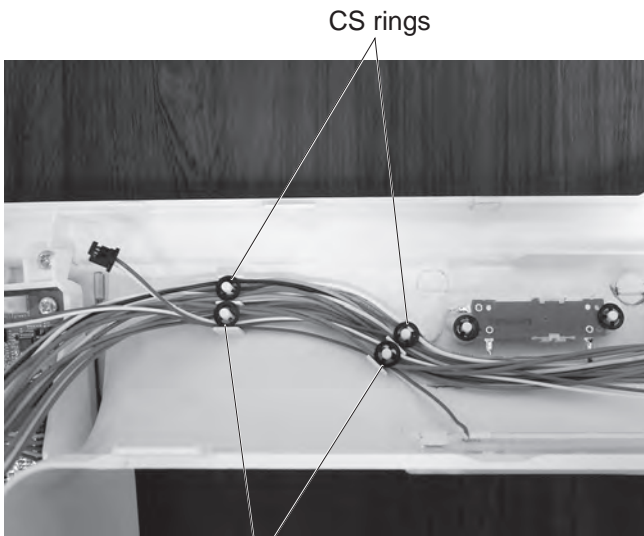

CS rings

Printed circuit board F

To remove:

1. Remove the front cover (see page 6-7).
2. Disconnect the connectors from the circuit board A (see page 10-11).
3. Remove the CS rings.
4. Remove the setscrews, and the circuit board F.

To attach:

1. Follow the above procedure in reverse.

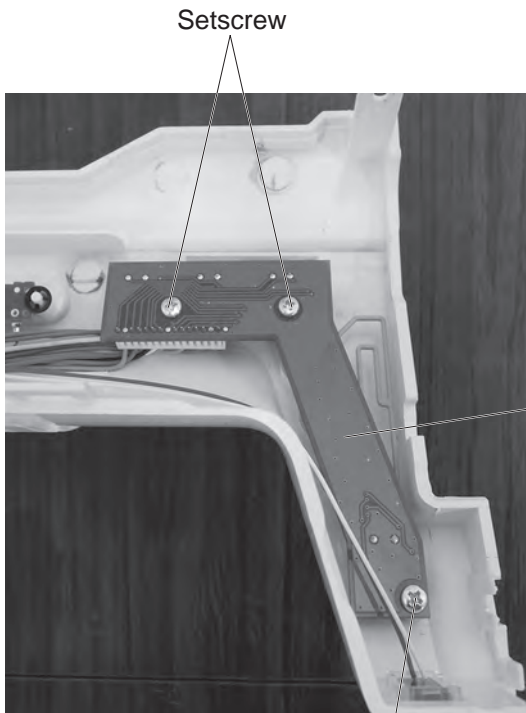

Setscrew

Printed circuit board F

Setscrew

Replacing Electronic Components

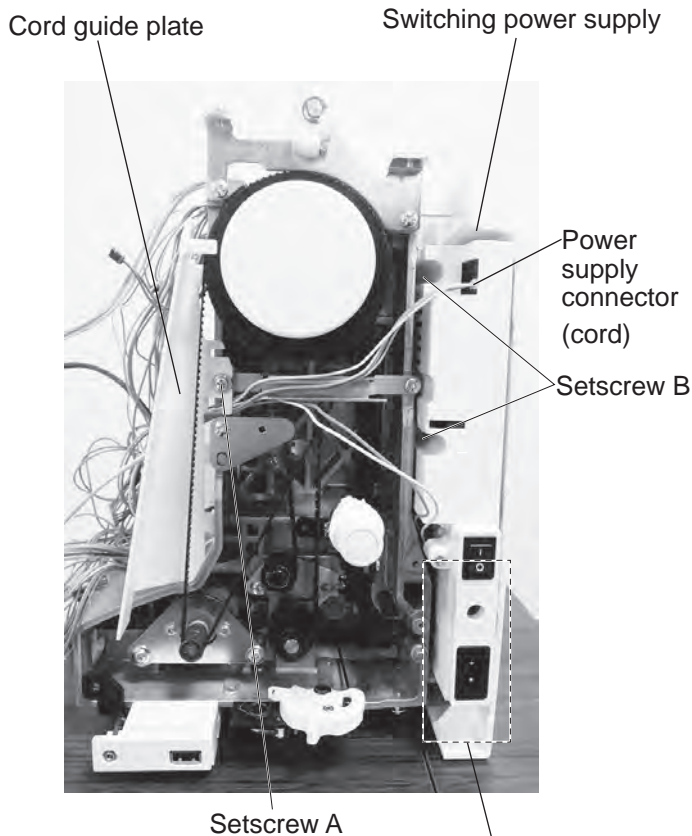

Switching power supply



Power supply connector (cord)



Setscrew B



Foot control connector A

Switching power supply unit

To remove:

1. Remove the top cover, the belt cover and the front cover (see page 1, 2 and 6-7).
2. Loosen the setscrew A. Remove the cord guide plate.

3. Disconnect the power supply connector from the switching power supply unit.

4. Disconnect the foot control connector A.

5. Remove the setscrews B (3 pcs.), and the switching power supply.

To attach:

1. Follow the above procedure in reverse.

Replacing Electronic Components

Driving motor

To remove:

1. Remove the belt cover, the top cover and the front cover (see pages 1, 2 and 6).
2. Remove the setscrews (2 pcs) and the motor belt. Remove the driving motor.

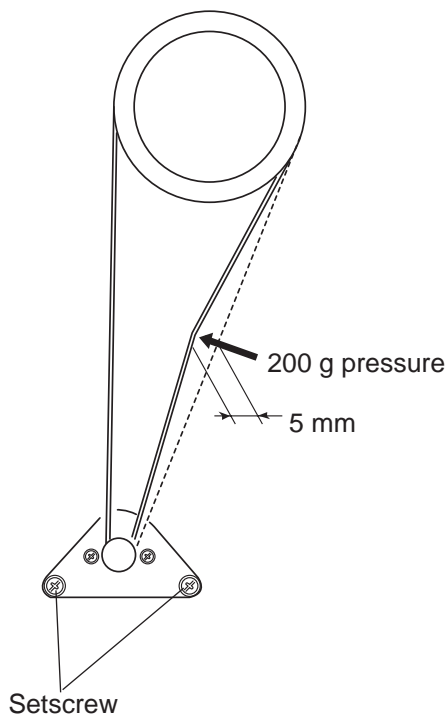
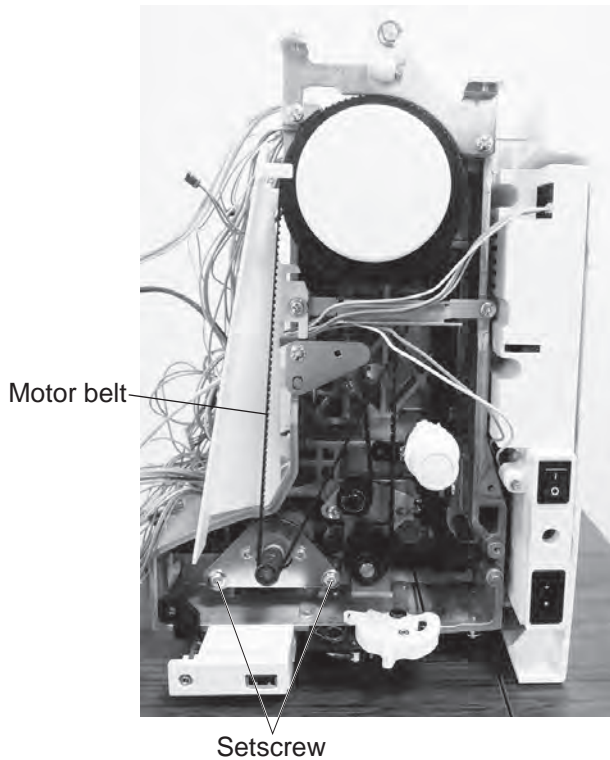

To attach:

1. Attach the driving motor. Tighten the setscrews temporarily.
2. Adjust the motor belt deflection to about 5 mm by pressing the middle of the motor belt with your finger with approximately 200 grams of pressure.
3. Tighten the setscrews securely.
4. Attach the front cover, the top cover and the belt cover.

Replacing Electronic Components

Setscrew A



Thread tension unit

To remove:

1. Remove the belt cover, top cover and the front cover (see pages 1, 2 and 6-7).
2. Remove the setscrews A and B.

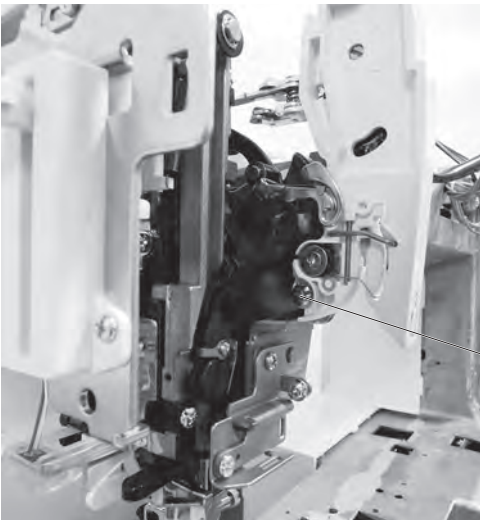

Setscrew B

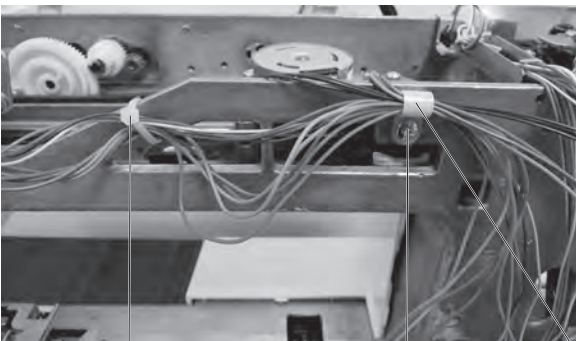

Cable tie A

Setscrew C

Cable tie B

3. Cut the cable tie A. Be careful not to cut the cables. Remove the setscrew C and cords from the cable tie B. Remove the thread tension unit.

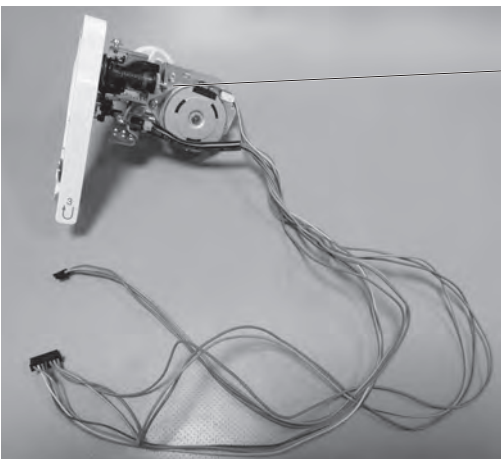

Thread tension unit

To attach:

1. Follow the above procedure in reverse.
2. Check the upper thread tension (see page 24).

Mechanical Adjustment

Feed dog height

When the foot pressure dial is at "7" and the presser foot A is lowered, the highest position of the feed dog should be 0.80 to 0.90 mm from the surface of the needle plate.

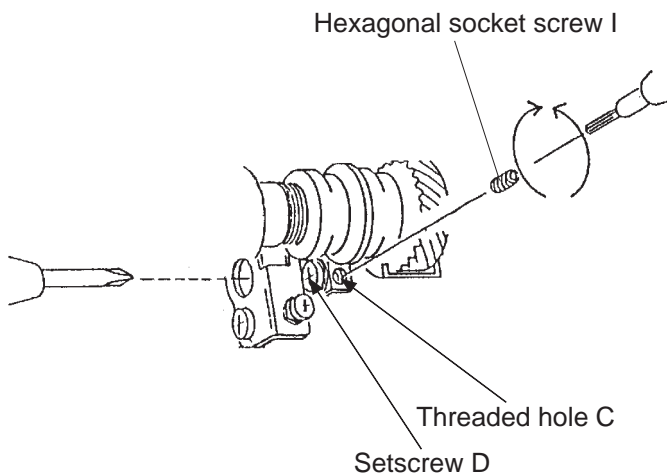
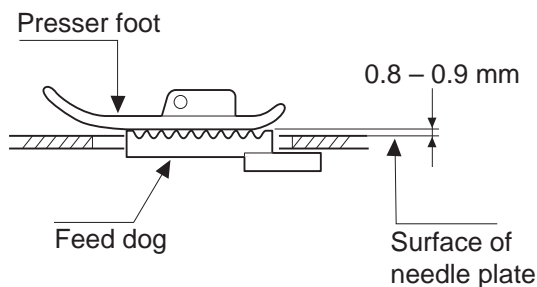
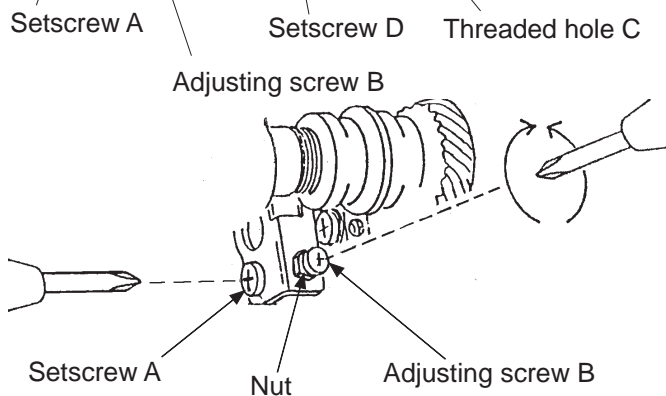
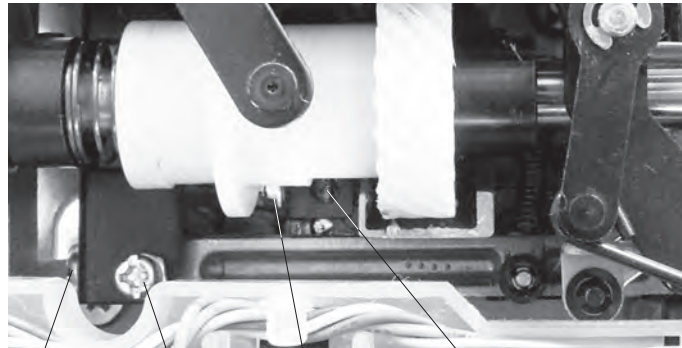

Adjustment 1:

1. Attach the zigzag foot A. Remove the base cover and bed cover (see page 2-3).
2. Turn the power switch ON. Adjust the foot pressure to the maximum (AUTO+4) in the ordinary sewing setting mode. Adjust the stitch length to the maximum (5.0).
3. Press the presser foot lifter button to lower the presser foot.
4. Turn the handwheel toward you to raise the feed dog to its highest position.
5. Loosen the setscrew (A).
6. Loosen the nut with a socket wrench. Turn the adjusting screw and adjust the feed dog height to 0.85 mm.
7. Tighten the nut and setscrew (A).
8. Turn the handwheel and check that the feed dog teeth are parallel with the surface of the needle plate. If not, follow the adjustment procedure below.

Adjustment 2:

If the feed dog is not parallel to the surface of the needle plate at its highest position, make the adjustment as follows:

* For this adjustment, a hexagonal socket screw 4x6 I, part No. 000111108 is required.

1. Insert a hexagonal socket screw I, part no. 000111108 into the threaded hole (C) until it stops.(use an Allen wrench of 2 mm width across flats).
2. Turn the setscrew D (left hand screw) clockwise to loosen it.
3. Turn the hexagonal socket screw I until the feed dog is parallel with the surface of the needle plate.
4. Tighten the setscrew D by turning it counterclockwise.
5. Remove the hexagonal socket screw I.
6. Attach the bed cover and base cover.

After finishing adjustment, return the foot pressure to AUTO.

Mechanical Adjustment

Needle drop position

When the straight stitch is selected, the needle should be positioned in the center of the needle plate hole.

When the needle drop position is set at "0.0" and "9.0", the clearance between the side of the needle and the needle hole should be 0.2 mm or more.

Fig. 1

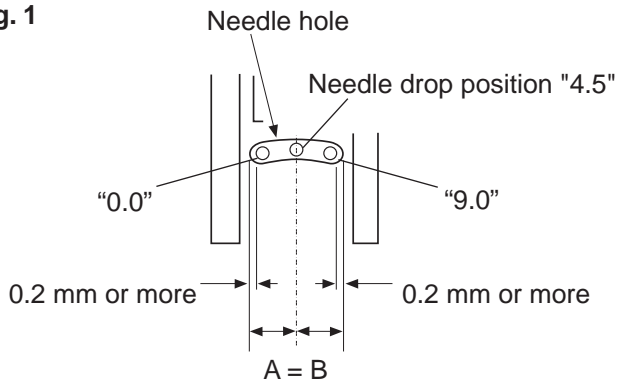

To adjust:

1. Attach the #14 needle. Turn the power switch ON and select straight stitch #1.
2. Check the clearance between the needle and the side of the needle hole when the needle drop position is set at "0.0" and "9.0" respectively.

3. If the clearance is less than 0.2 mm, adjust it as follows.

Loosen the hexagonal socket screw (use an Allen wrench of 2 mm width across flats).



Hexagonal socket screw



Eccentric pin

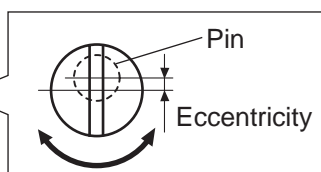

4. Turn the eccentric pin to get 0.2 mm or more clearance. The direction of eccentric pin should be as shown. Tighten the hexagonal socket screw. Attach the straight needle plate and check if the needle drops in the center of the needle hole. Check the hook timing and the needle bar height after this adjustment (see page 20 and 21).

Mechanical adjustment

Clearance between needle and tip of the rotary hook (method 1)

The clearance between the needle and the point of hook should be -0.1 to $+0.05$ mm.

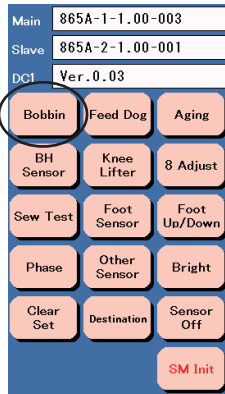

1. Remove the top cover (see page 1).
2. Remove the presser foot, the needle plate and the bobbin holder.
3. Attach the test pin.
4. Turn the power switch ON while pressing the Start/ Stop button and the Reverse stitch button. The LCD shows the factory setting mode.
Press "Bobbin" key. The machine will set the zigzag width at maximum.
5. Turn the handwheel toward you until the tip of the hook comes behind the test pin.

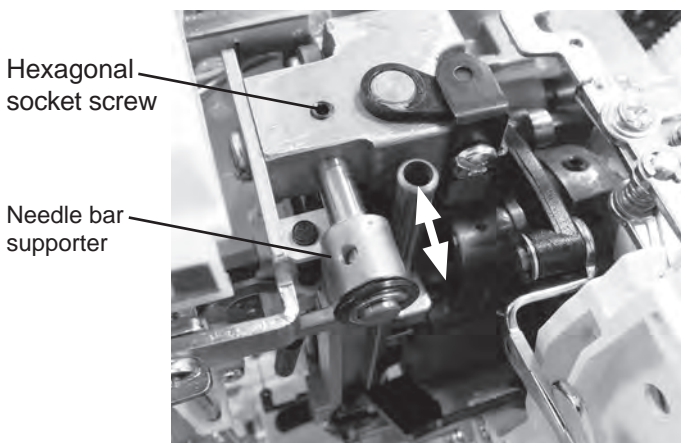
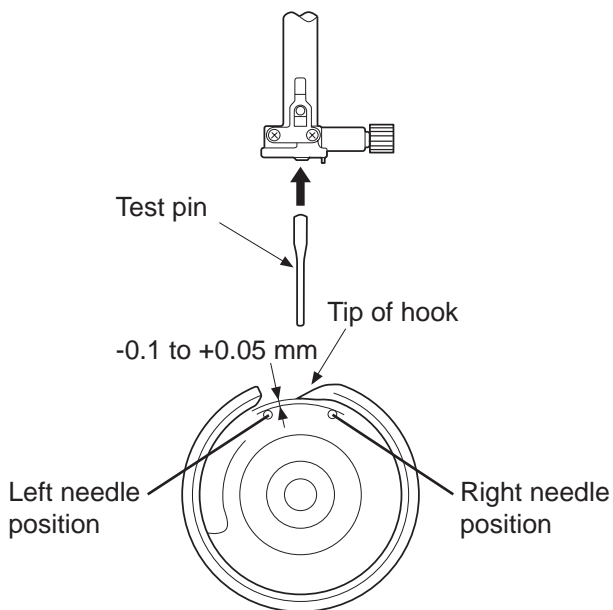

6. Loosen the hexagonal socket screw (use an Allen wrench of 2 mm width across flats) and move the needle bar supporter in the direction of the arrow so the test pin just touch the tip of the hook. Tighten the hexagonal socket screw.

Clearances A and B must be even

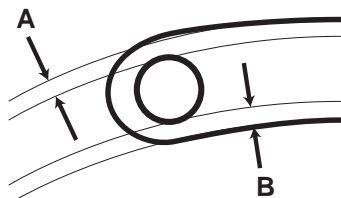

7. Attach the bobbin holder and the needle plate. Check the needle drop position. The needle drops in the center of the needle plate hole as shown.

If the clearances A and B are not even, adjust the needle drop position first and then adjust the clearance between the needle and the tip of the hook by the method (2) on the next page.

Mechanical adjustment

Clearance between needle and tip of the rotary hook (method 2)

The clearance between the needle and the point of hook should be -0.1 to $+0.05$ mm.

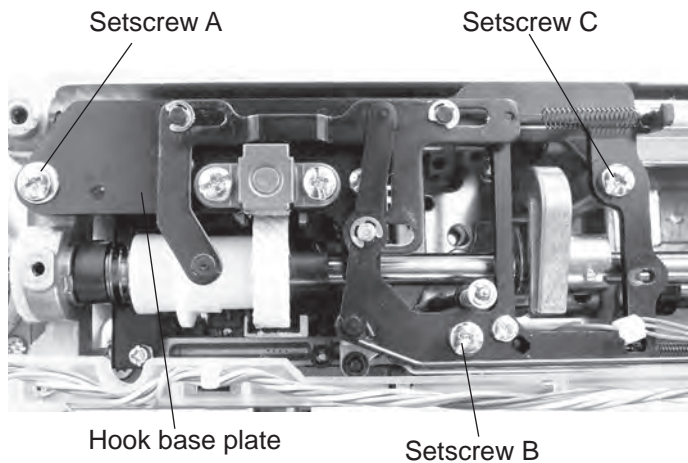

1. Remove the bed cover (see page 3).
2. Loosen the setscrews A, B and C. Tighten the setscrew C lightly.
3. Turn the handwheel toward you until the tip of the hook comes behind the test pin. Adjust the clearance between the needle and the tip of the rotary hook, by moving the hook base plate up or down, so the test pin just touch the tip of the hook.
4. Tighten the setscrews A, B and C.
5. Check the backlash between the lower shaft gear and the hook drive gear. If the backlash is too great or the engagement of the gears is too tight, adjust the backlash (see page 22).

* Check the hook adjustment and needle bar height after this adjustment (see page 20 and 21)

Mechanical Adjustment

Hook timing

The amount of ascending travel of the needle bar from its lowest position to the position (Needle drop position 0.0) where the tip of the rotary hook exactly meets the right side of the needle should be 3.70 to 4.00 mm

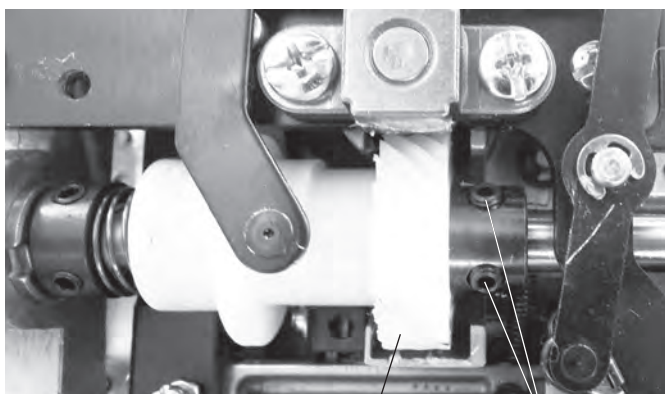
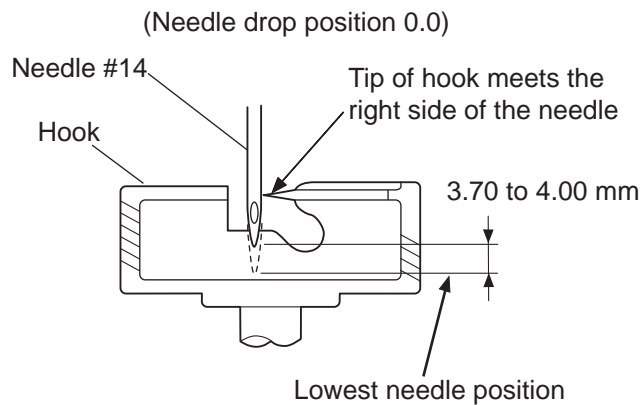
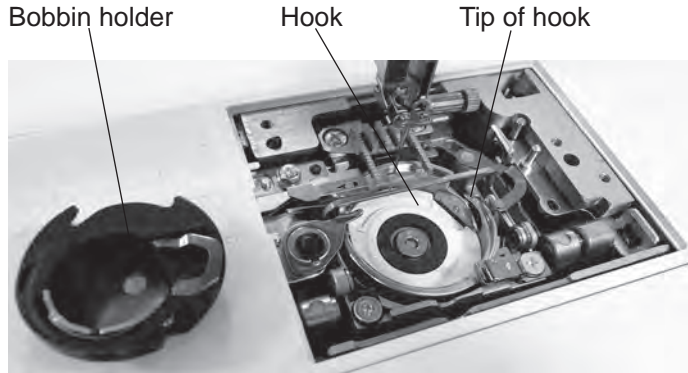

Lower gear Setscrews A

To adjust:

1. Remove the bed cover and base cover (see page 3).
2. Attach the needle #14.
3. Turn the power switch ON. Select straight stitch. Set the needle drop position at "0.0".
* Do not turn the switch OFF.
4. Remove the presser foot, the needle plate and the bobbin holder.
5. Turn the handwheel toward you to lower the needle at its lowest position.
6. Loosen the hexagonal socket screw (use an Allen wrench of 2 mm width across flats).
7. Turn the handwheel toward you to raise the needle bar by 3.85 mm from its lowest position.
8. Turn the lower shaft gear until the tip of rotary hook meets with the right side of the needle. Tighten the setscrews A.
* Check the needle bar height after this adjustment.
9. Attach the bed cover and base cover.

Mechanical Adjustment

Needle bar height

The distance between the upper edge of the needle eye and the hook race should be in the range of 1.6 to 2.0 mm when the tip of the hook meets right side of the needle in the needle drop position "0.0" as the needle ascends from its lowest position.

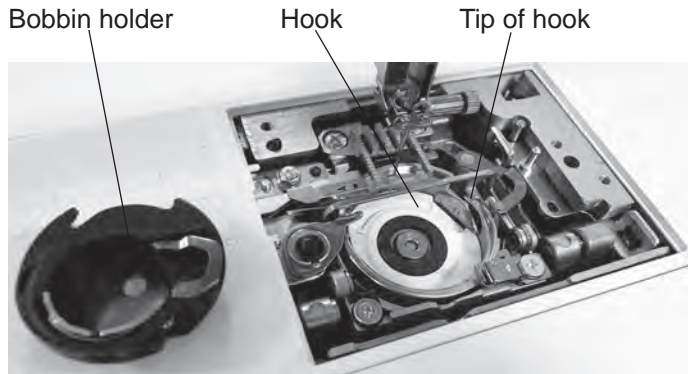

1. Attach the needle #14.
2. Turn the power switch ON. Select straight stitch. Set the needle drop position at "0.0".
* Do not turn the switch OFF.
3. Remove the presser foot, the needle plate and the bobbin holder.
* Cover the needle plate with the fabric to prevent damaging the needle plate when removing.

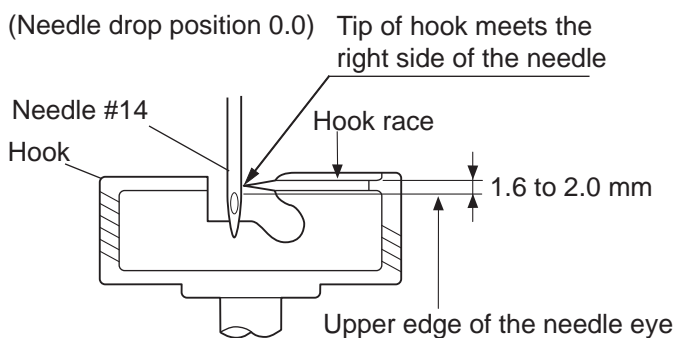

4. Turn the handwheel toward you until the tip of hook meets the right side of the needle.

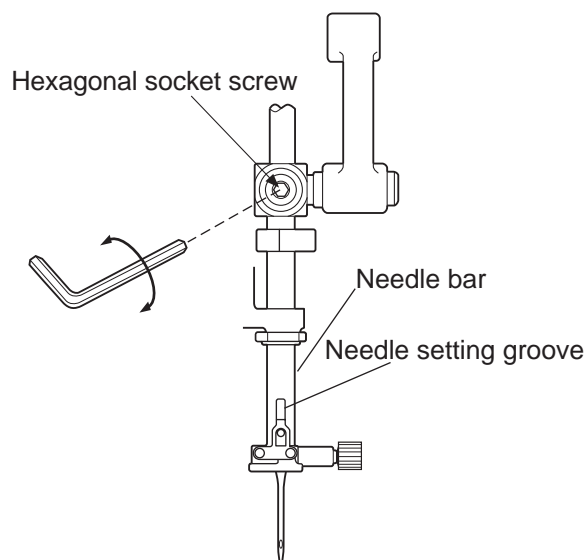

5. Loosen the hexagonal socket screw (use an Allen wrench of 2 mm width across flats).
6. Move the needle bar to adjust the the needle bar height.
Tighten the hexagonal socket screw.
Be careful not to turn the needle bar.
7. Attach the bobbin holder and needle plate.

Mechanical Adjustment

Backlash between hook drive gear and lower shaft gear

The rotary play of the hook should be 0.8 mm or less when the tip of rotary hook is within the width of feed dog.

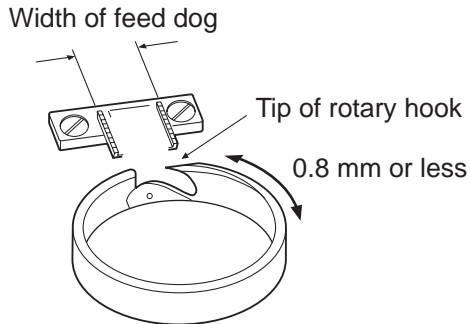

1. Remove the base cover and bed cover (see page 3).
2. Remove the presser foot, the needle plate and the bobbin holder.
 - * Cover the needle plate with the fabric to prevent damaging the needle plate when removing.
3. Turn the handwheel toward you so the the tip of the rotary hook is within the width of feed dog as shown. Check the rotary play of the hook.

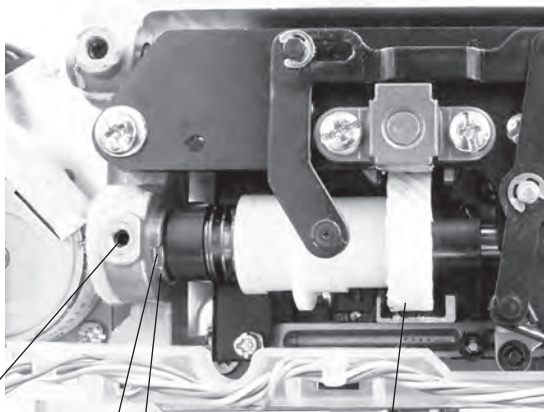

4. If the backlash is too much or too little, loosen the hexagonal socket screw (C) and (D) and following the adjustment procedure.
 - * If the backlash is too great (more than 0.8 mm), turn the both lower shaft bushings in direction A.
 - * If the engagement of gear is too tight, and the machine does not turn smoothly, turn the both lower shaft bushings in direction B. Adjust the notch of the lower shaft bushing as well.
5. Tighten the hexagonal socket screws (C) and (D).
6. Attach the base cover, bed cover, the presser foot, needle plate and the bobbin holder.

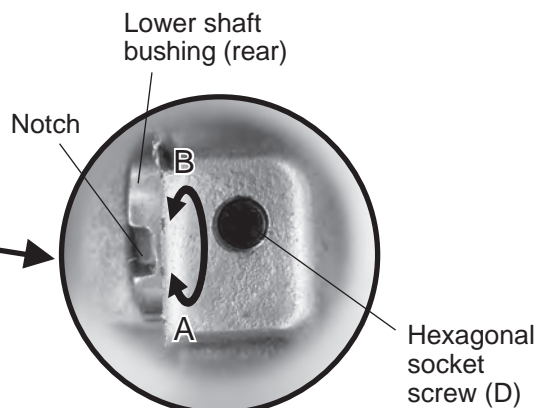
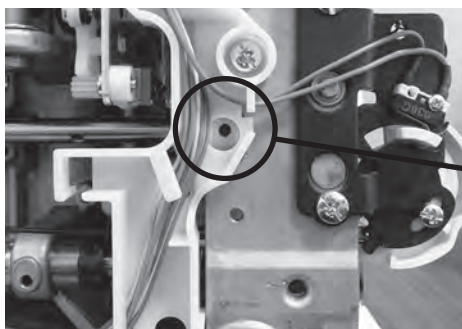
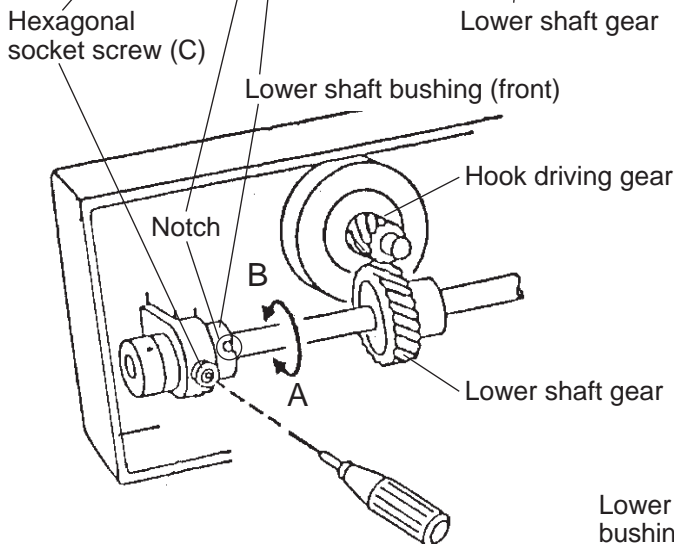

Mechanical adjustment

Upper shaft shield plate position

When the machine is set for zigzag stitch, the needle should start to swing 7.7 ± 0.5 mm above the surface of the needle plate.

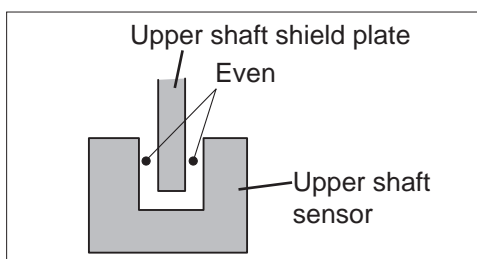
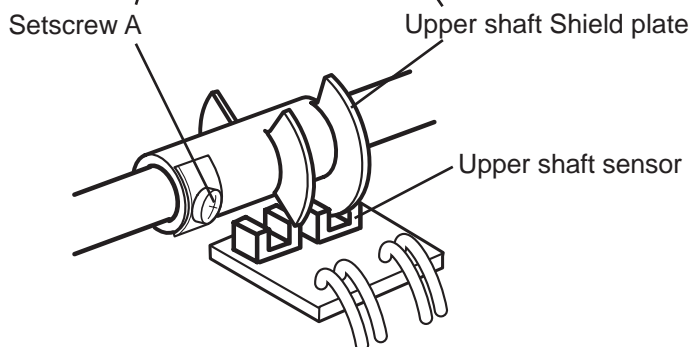
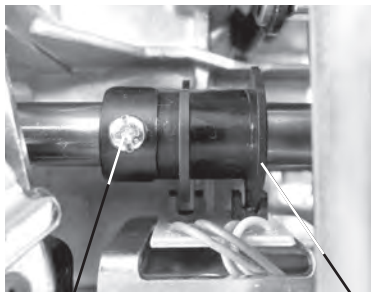
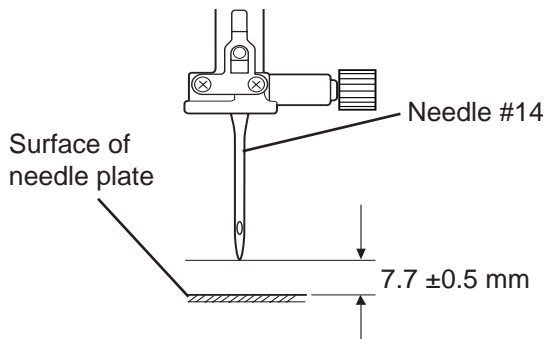
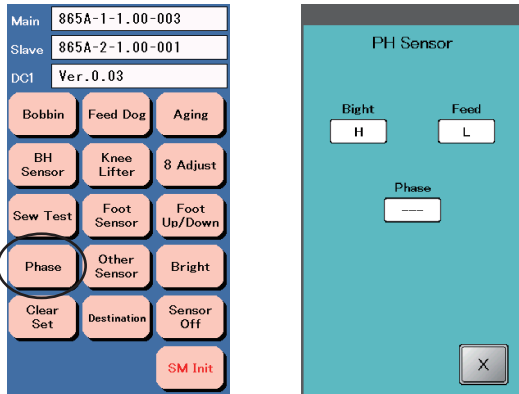

To check:

1. Attach the needle #14.
2. Turn the power switch ON while pressing the Start/ Stop button and the Reverse stitch button. The LCD shows the Factory Setting Mode. Press "Phase" key.
3. Turn the handwheel toward you slowly to bring the needle up from its lowest. The indication below "Bight" changes from L to H.
4. The needle height should be 7.7 ± 0.5 mm above from the surface of the needle plate. If not, adjust the upper shaft shield position.

To adjust:

1. Remove the top cover (see page 1).
2. Turn the handwheel toward you and raise the needle 7.7 mm above the surface of the needle plate.
3. Loosen the setscrew of the upper shaft shield plate. Turn the upper shaft shield plate until the indication changes from L to H. Tighten the setscrew.

The position of the upper shaft shield plate should be in the center of the upper shaft sensor.

Mechanical adjustment

Upper thread tension

The standard upper thread tension should be 59 to 67 grams when the machine is set for pattern No.1 and the thread tension is set at "3.4", measured with a #50 polyester thread being pulled at approximately 110 mm/sec. in the direction of arrow.

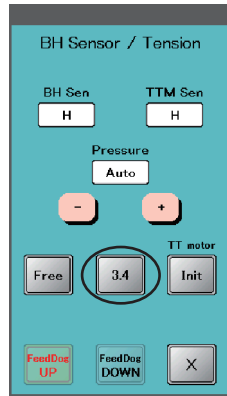
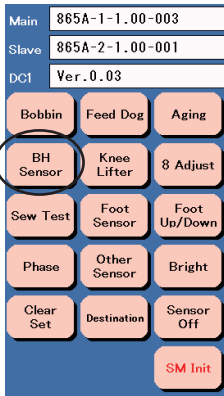

1. Turn the power switch ON while pressing the Start/ Stop button and the Reverse stitch button. The LCD shows the Factory Setting Mode. Press "BH Sensor" key.

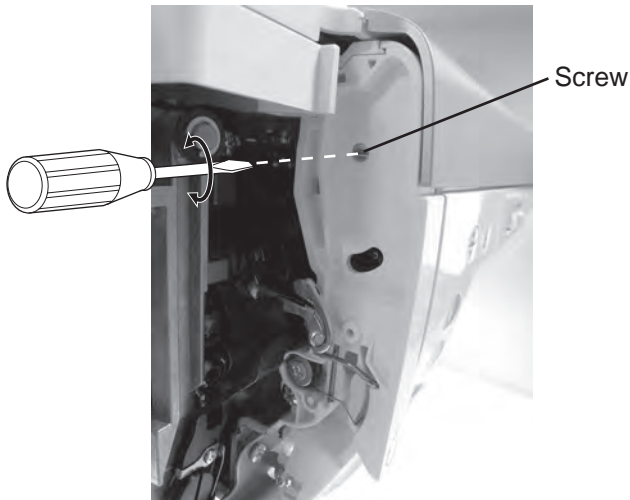

2. Thread #50 polyester thread to the machine.
3. Set the thread tension "3.4" by pressing "3.4" key.
4. Open the face plate.
 - (A) If the thread tension is less than 59 gr, turn the screw in the direction of "+".
 - (B) If the thread tension is more than 67 gr, turn the screw in the direction of "-".

Pulling direction: (pulling speed 110 mm/sec.)

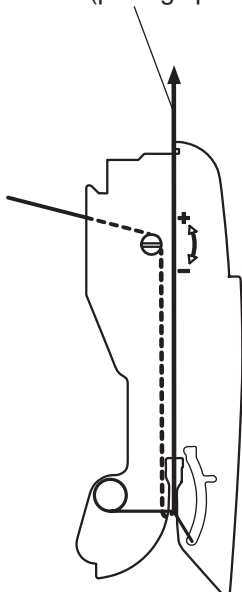

Mechanical adjustment

Tension release mechanism

When the presser foot lifter is raised, the tension release mechanism should work correctly.

Convex is NOT set at tension release claw

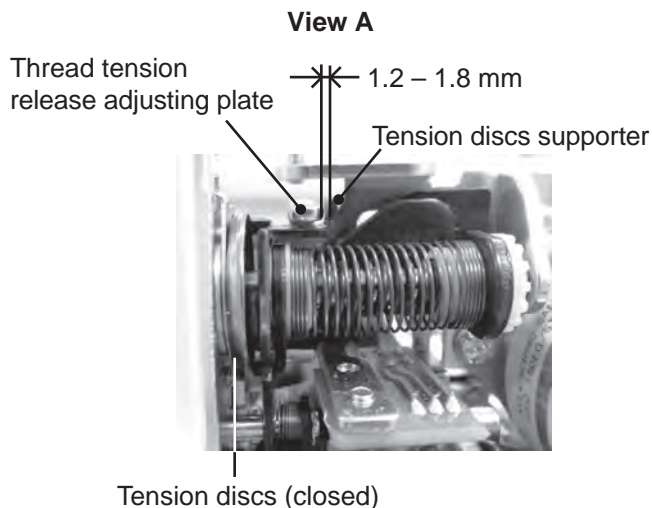
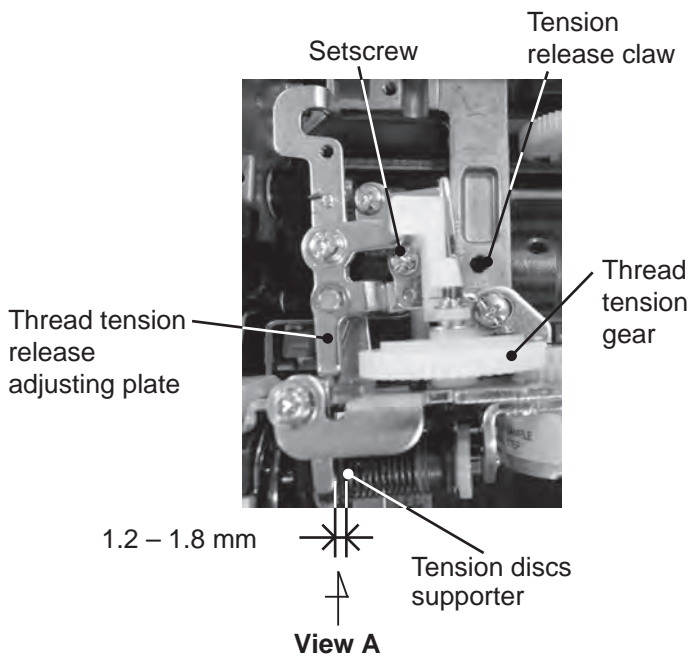
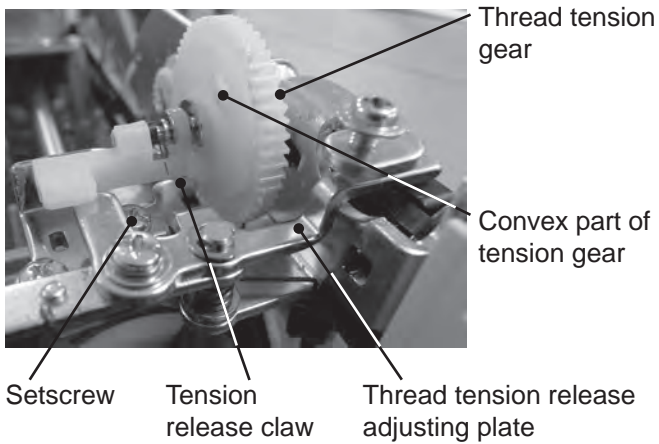

1. Remove the belt cover and top cover (see pages 1-2).
2. Remove the front cover (see page 6-7).
3. Turn the power switch off. Turn the thread tension gear until the convex part of tension gear is NOT set at the tension release claw.
4. Loosen the setscrew.
5. Adjust the clearance between the tension release adjusting plate and the tension disc supporter to 1.2 mm – 1.8 mm.
6. Turn the thread tension gear until the convex part of tension gear is set at the tension release claw. Be sure that the tension release adjusting plate touches the tension discs supporter and the tension discs opened slightly.

Convex is set at tension release claw

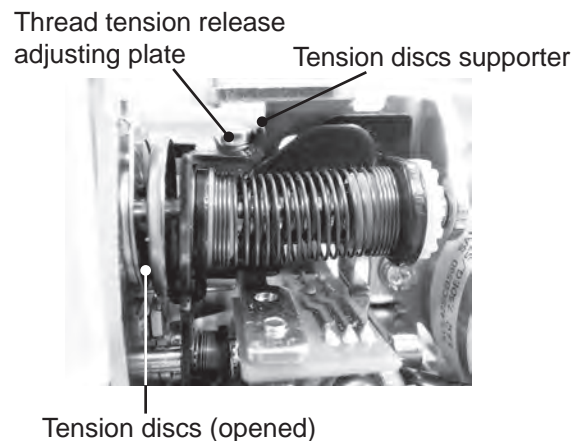
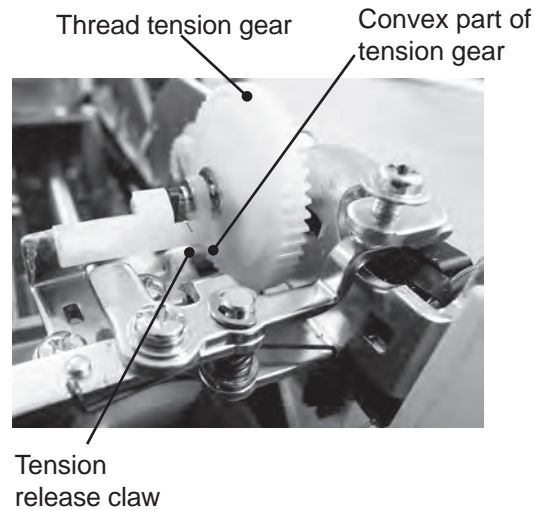

Mechanical adjustment

Replacing Needle threader hook

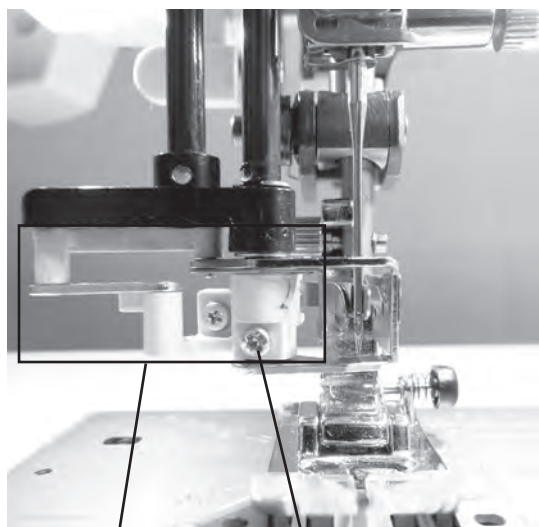

Threader unit

Setscrew



Hook holder (unit) (862627005)

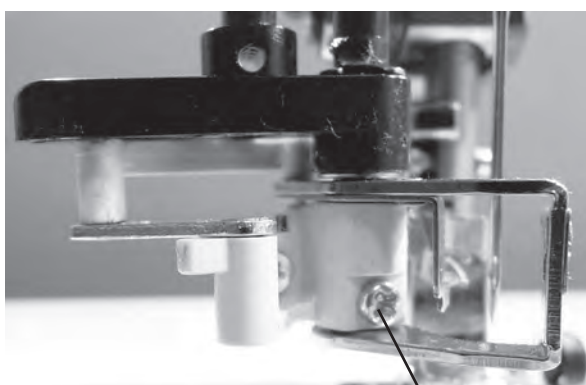

Pin is engaged in the slot

Setscrew

To remove:

1. Push down the threader lever as far as it will go and hold it in place. Loosen and remove setscrew.
2. Release the threader lever slowly while holding the threader unit to disengage it from the threader shaft.

3. Disassemble the threader unit and replace the threader hook. Refer the following part number when ordering service parts.
862627005: Hook holder (unit)

To attach:

1. Assemble the threader unit and attach them to the threader shaft by inserting the shaft into the holes.
2. Make sure the pin is engaged in the slot.
Secure the threader unit to the threader shaft by tightening setscrew.
Adjust the needle threader hook position (see page 27).

Mechanical adjustment

Needle threader hook position

If the hook of the threader plate is damaged, change or adjust the part as follows:

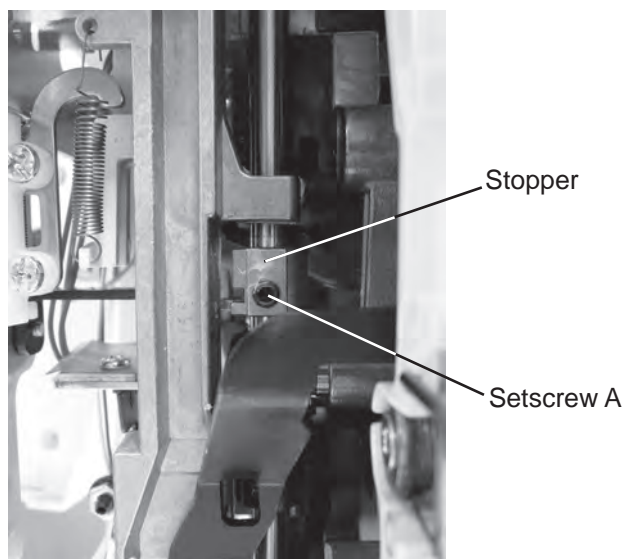

1. Push down the threader lever and hold it just before the threader hook enters the needle eye.
2. If the threader hook is not aligned vertically with the needle eye, loosen the setscrew A. Adjust the stopper position so that the hook enters into the needle eye. Tighten the setscrew A.



Setscrew B

3. If the threader hook is not aligned laterally with the needle eye, loosen the setscrew B. Adjust the lateral position so that the hook enters into the needle eye. Tighten the setscrew B.

Mechanical adjustment

Thread drawing lever

The standard height of the thread drawing lever from the surface of bobbin holder should be in the range of 5.5 – 6.0 mm.

Hook race Thread drawing lever



1. Remove the presser foot, the needle plate and the bobbin holder.

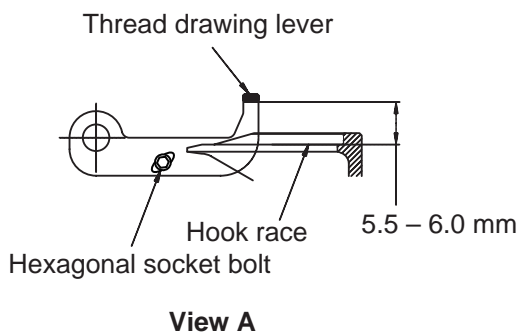

2. Loosen the hexagonal socket bolt (use an Allen key of 1.5 mm width across flats) . Adjust the distance between the lower part of thread drawing lever and the hook race to 5.75 mm by moving the thread drawing lever up or down.

3. Tighten the hexagonal socket bolt.

Mechanical adjustment

Upper feed dog (1)

The clearance between the upper feed link shaft and upper feed lower shaft should be 2.5 mm when the upper feed adjusting dial is set to "0".

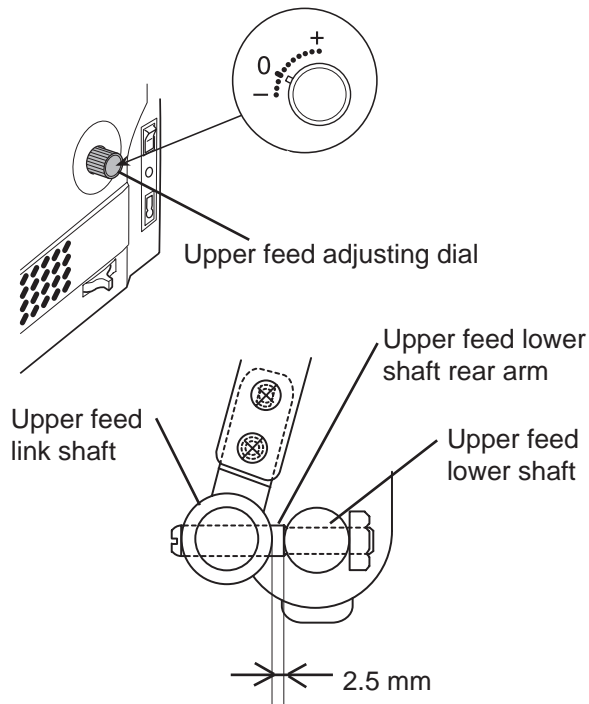

View from the belt cover side

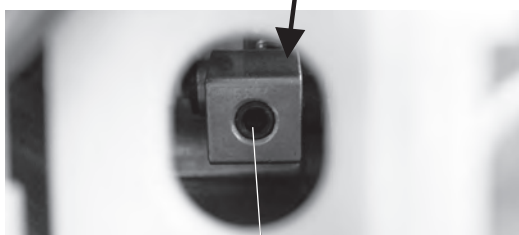
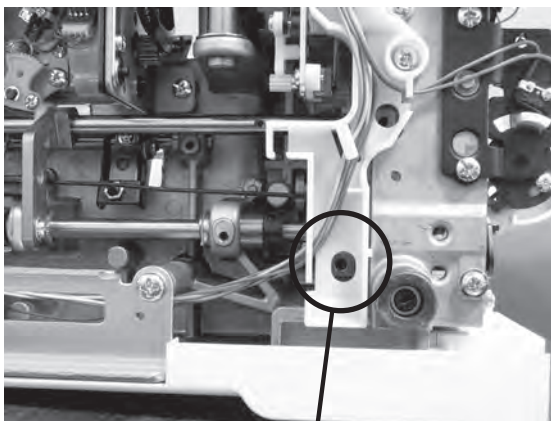

Setscrew

To check:

1. Set the upper feed adjusting dial at "0".
Remove the belt cover and base cover (see page 2-3).
2. Turn the power switch on and select () stitch.
Lower the feed dog.
3. Press the needle up/down button twice to raise the needle, and the upper feed dog position will be initialized.
4. Check if the clearance between the upper feed link shaft and upper feed lower shaft is 2.5 mm.
If not, adjust it as follows.

To adjust:

1. Loosen the setscrew (use an Allen wrench of 2 mm width across flats) on the upper feed adjusting arm (1).
Adjust the clearance between the upper feed link shaft and upper feed lower shaft to 2.5 mm.

Mechanical Adjustment

Upper feed dog (2)

The clearance between the dual feed foot and upper feed dog should be 4 mm when the stitch length is set at "0".

* Check the upper feed dog (1) (see page 29) before this adjustment.

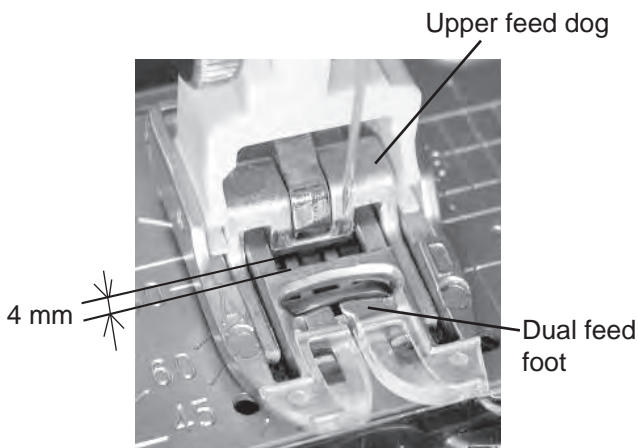
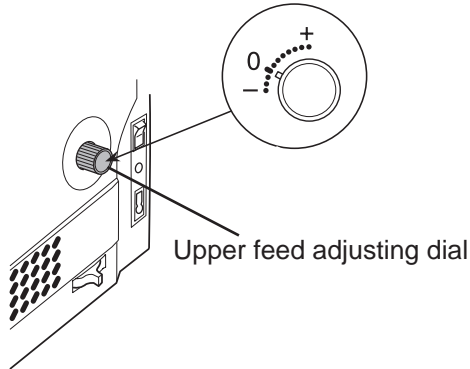

To check:

1. Attach the dual feed foot.
2. Turn the power switch on and select straight stitch (D1). (Be sure that the machine is not locked.)
Turn the drop feed lever to drop the feed dog.
Press the adjusting key and set the stitch length at "0".
3. Turn the upper feed adjusting dial to set the dial at "0".
4. Press the needle up/down button twice to raise the needle.
* In order to initialize the feed dog position, press the needle up/down button twice and reset the needle position even though needle position is set at raised position.
5. Lower the presser foot.
Turn the power switch off.
6. The clearance between the dual feed foot and upper feed dog should be 4 mm. If not, follow the procedure below.

View from the right upper corner of the machine

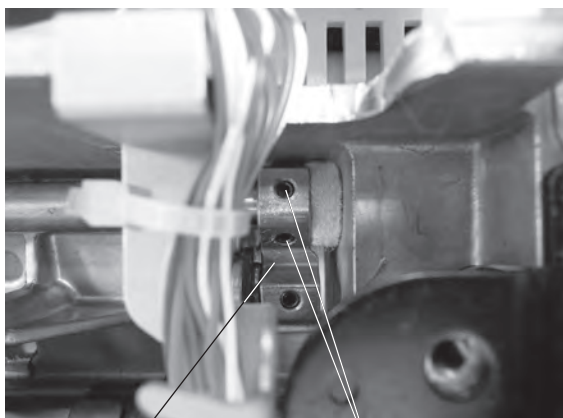

Upper feed upper shaft rear arm

Hexagonal socket screws

To adjust:

1. Remove the top cover (see page 1).
2. Loosen the hexagonal socket screws on upper feed rear arm (use an Allen wrench of 2 mm width across flats).
3. Insert the 4 mm spacer between the upper feed dog and dual feed foot to adjust the clearance. Tighten the hexagonal socket screws.

Mechanical Adjustment

Upper feed dog (3)

The tip of the needle height should be 0 to 1 mm above the surface of the needle plate when the toe of the dual feed foot touch the needle plate.

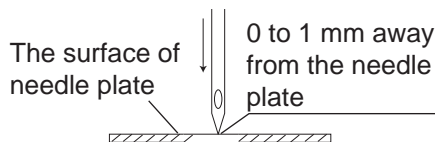
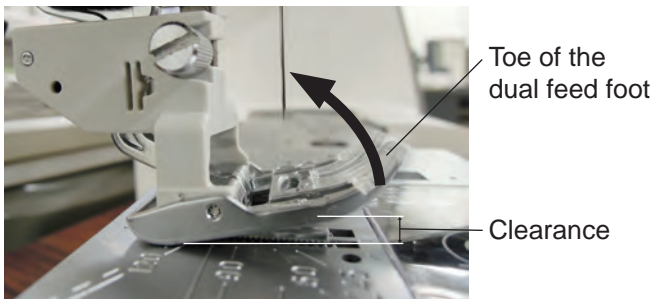
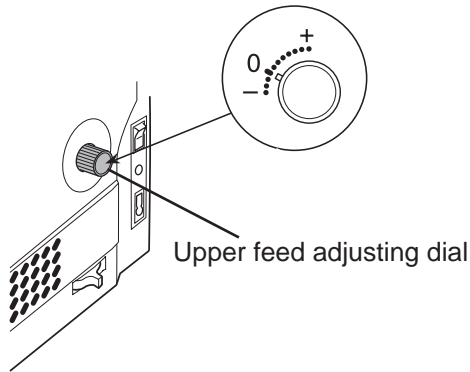

Hexagonal socket bolt

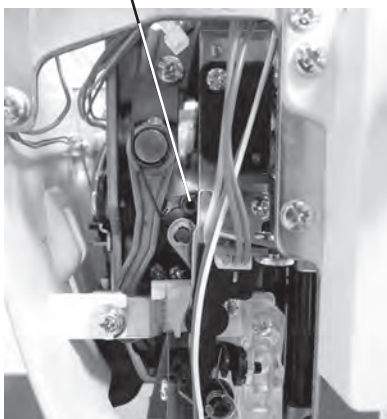

To check:

1. Set the upper feed adjusting dial at "0".
Attach the dual feed foot.
2. Turn the power switch on and select () stitch.
Lower the feed dog.
3. Press the needle up/down button twice to raise the needle, and the upper feed dog position will be initialized.
4. Press the presser foot lifter button to lower the presser foot.
Turn the power switch off.
5. Raise the toe of the dual feed foot and leave it as it is.
6. Turn the handwheel toward you to lower the needle until the needle tip comes 1 mm or less above the needle plate.
7. The toe of the foot lands on the needle plate and there is no gap to allow the foot flapping.
If not, adjust it as follows.

To adjust:

1. Open the face plate. Loosen the hexagonal socket bolt (use an Allen wrench with 2.5 mm width across flats).
2. Turn the handwheel toward you until the needle tip matches with the surface of the needle plate.
3. Tighten the hexagonal socket bolt while pressing the dual feed foot against the needle plate.
4. Check if there is no gap (see step 7 above).

Mechanical adjustment

Buttonhole lever

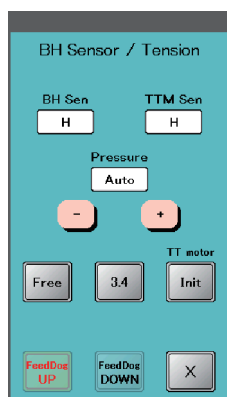
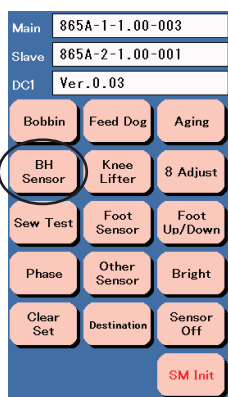

1. Turn the power switch ON while pressing the Start/ Stop button and the Reverse stitch button. The LCD shows the Factory Setting Mode. Press "BH Sensor" key.

Buttonhole lever guide Setscrew Hexagonal socket screw

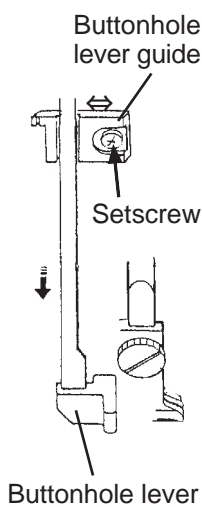
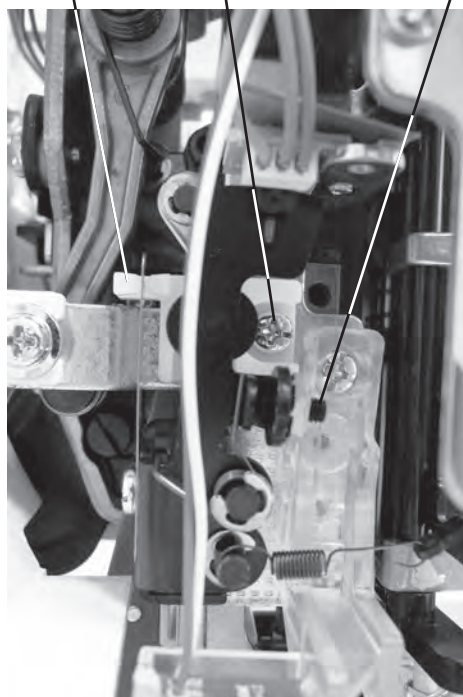

2. Open the face cover. Lower the Buttonhole lever. Loosen the setscrew on the buttonhole lever guide. Move the buttonhole lever guide to the left to adjust the position. Tighten the setscrew when the indication below "BH Sen" changes from "H" to "L".

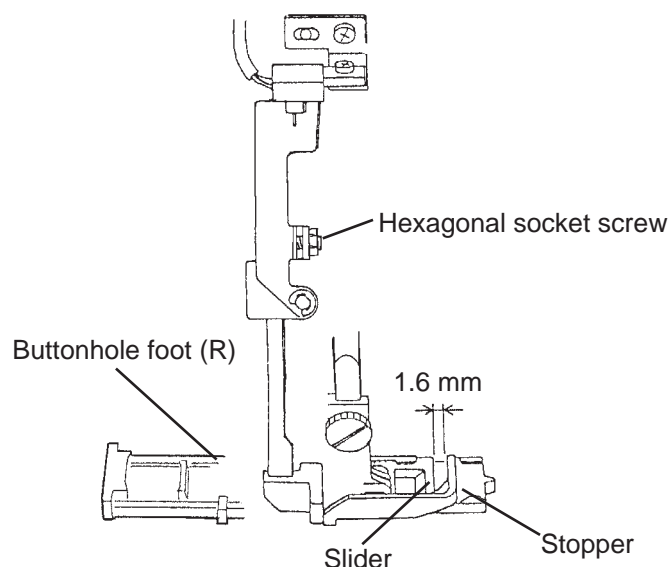

3. Attach the automatic buttonhole foot (R). Insert a 1.6 mm thick spacer between the stopper and slider of the foot.
4. Press the presser foot lifter button to lower the automatic buttonhole foot (R). Lower the buttonhole lever.
5. Turn the hexagonal socket screw counterclockwise (use an Allen wrench of 2 mm width across flats) until the indication below "BH Sen" shows "H". Turn the setscrew slowly clockwise until the indication changes to "L".

Mechanical adjustment

Thread cutter

The distance between the end of thread cutter plate slit and the end of moving cutter should be in the range of 0.4 to 1.2 mm.

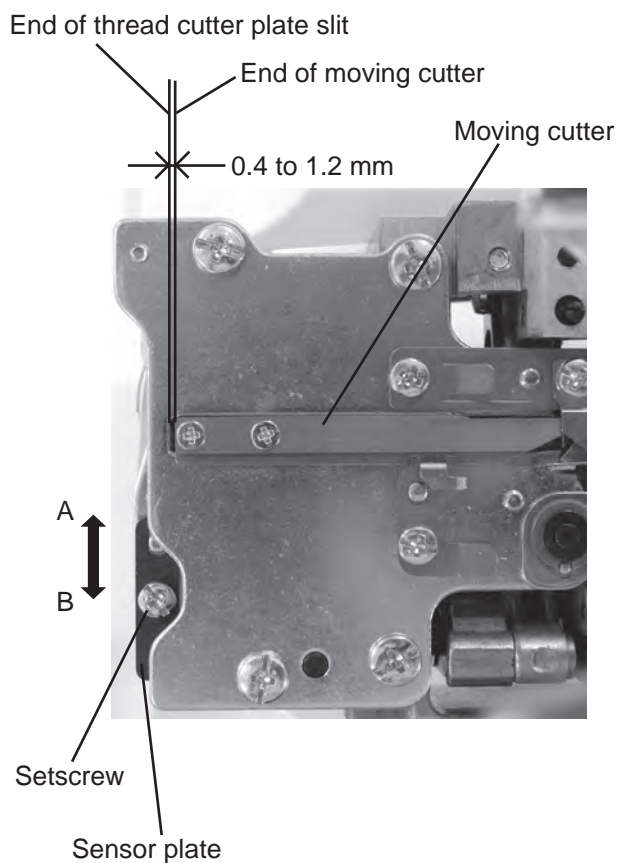
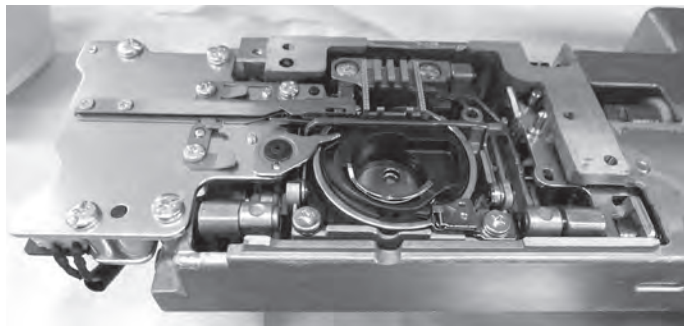

To check:

1. Remove the bed cover and free arm cover (see pages 3-4).
2. Turn the power switch ON.
The moving cutter motor is initialized, and moving cutter moves to its home position automatically.
3. The distance between the end of moving cutter and the end of thread cutter plate slit should be 0.4 to 1.2 mm.
If not, adjust it as follows.

To adjust:

1. Turn the power switch OFF. Loosen the setscrew on the sensor plate.
2. If the distance is smaller than 0.4 mm, move the sensor plate in the direction of A.
If the distance is larger than 1.2 mm, move the sensor plate in the direction of B.
3. Turn the power switch ON to initialize the cutter position and check if the distance is within 0.4 to 1.2 mm.
4. Attach the bed cover and free arm cover.

Mechanical adjustment

Presser bar lifter position

The clearance between the presser foot and the surface of the needle plate should be 6 mm when the presser foot is raised. The presser foot (zigzag foot A) should be parallel to the slot of the feed dog teeth when attached.

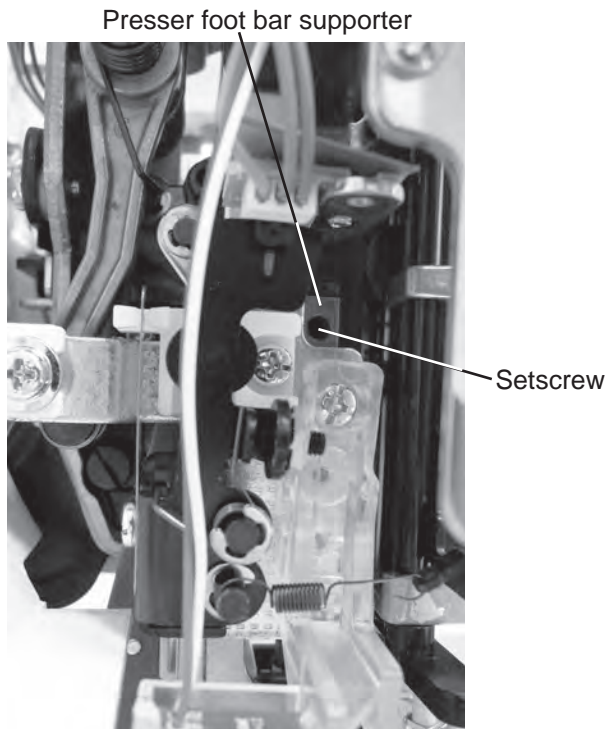

To adjust:

1. Attach the zigzag foot (A). Lower the feed dog.
2. Turn the power switch ON. Press the presser foot lifter button to lower the presser foot. Turn the power switch OFF.
3. Raise the presser foot with the presser foot lifter.
* You must use the presser foot lifter to raise the presser foot for this adjustment, otherwise you cannot adjust the presser foot height correctly.

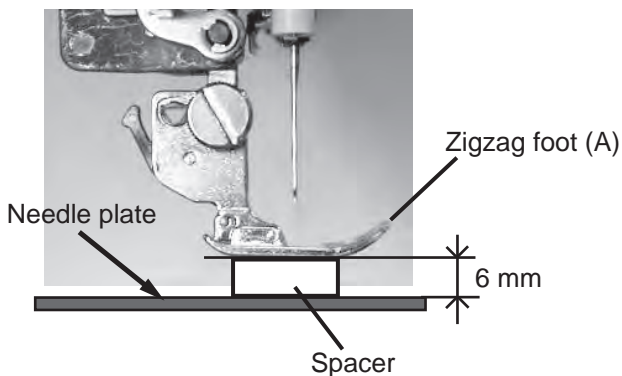

4. Open the face plate. Place the 6 mm spacer (block) between the presser foot and the needle plate. Loosen the setscrew on the presser bar supporter (use an Allen wrench of 2 mm width across flats).

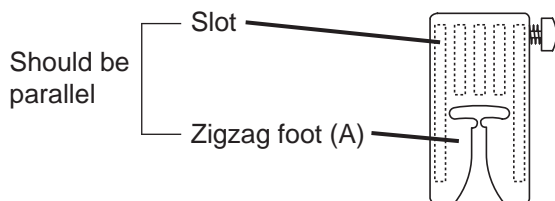

5. Adjust the presser foot (A) direction as illustrated so the slot for the feed dog teeth and the zigzag foot should be parallel. Tighten the setscrew while depressing the foot against the spacer.

Mechanical adjustment

Presser foot lifter stopper position (1)

The distance between the presser foot spring release base and the presser foot lifter should be in the range of 39.4 mm to 39.8 mm when the presser foot is raised with the presser foot lifter.

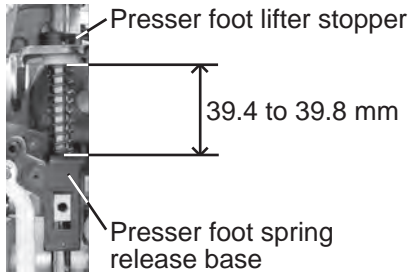

Preparation:

1. Turn the power switch ON. Press the presser foot lifter button to lower the presser foot. Turn the power switch OFF.
2. Raise the presser foot with the presser foot lifter.
3. Remove the top cover (see page 2).
4. Disconnect the connector from the face cover. Loosen the setscrew A. Remove the setscrews B and C. Remove the carrying handle supporter (front).

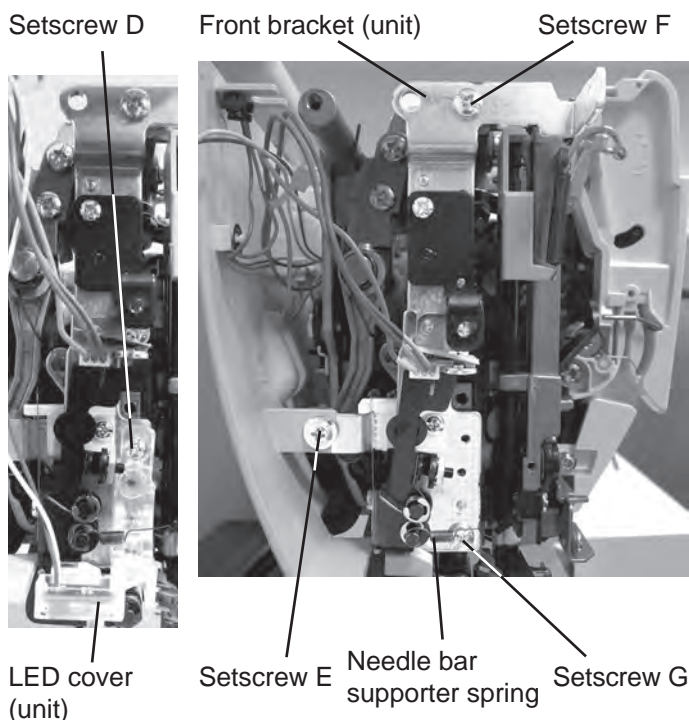
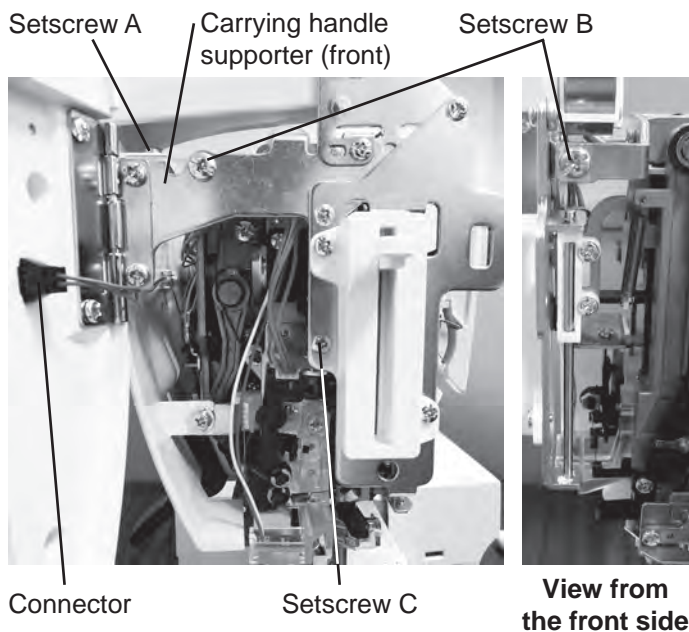

5. Remove the setscrew D and the LED cover (unit). Remove the needle bar supporter spring. Loosen the setscrew E. Remove the setscrews F and G. Remove the front bracket (unit).

Mechanical adjustment

Presser foot lifter stopper position (2)

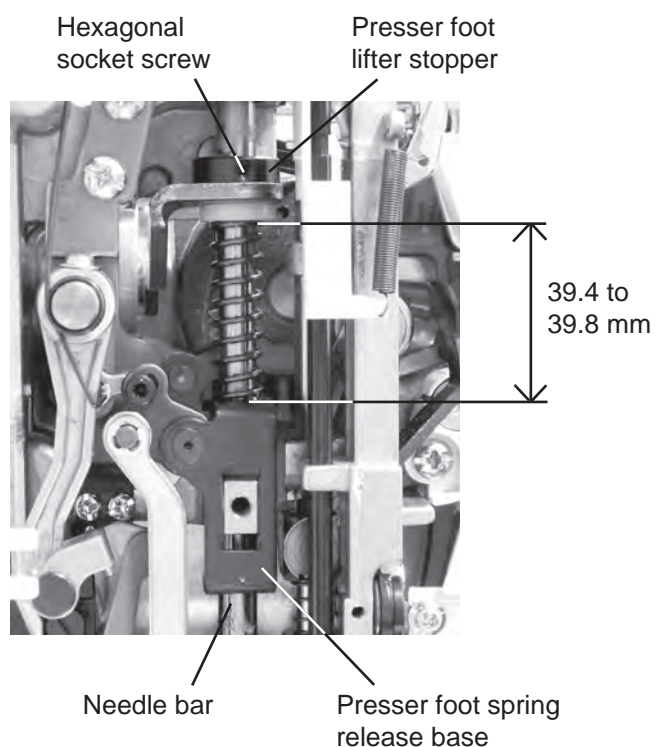

To adjust:

1. Turn the handwheel toward you to lower the needle.
Raise the presser foot lifter.
Loosen the hexagonal socket screw (use an Allen wrench of 2.5 mm width across flats).
2. Adjust the distance between the presser foot spring release base and the presser foot lifter stopper to 39.4 to 39.8 mm. Tighten the hexagonal socket screw.

Mechanical adjustment

Automatic presser foot lifter initializing position

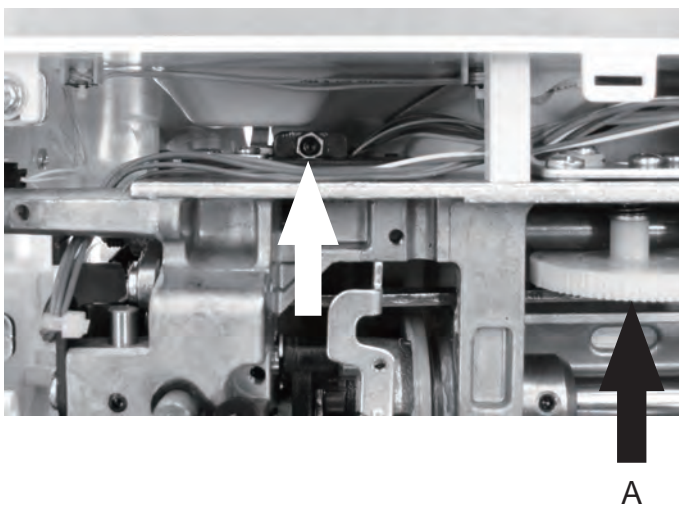
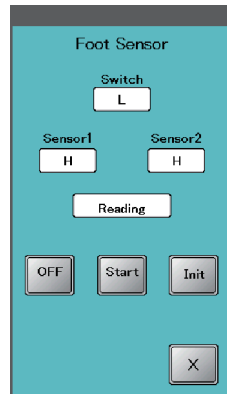
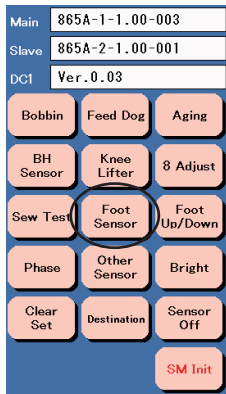

To adjust:

1. Remove the top cover.
2. Turn the power switch ON while pressing the Start/ Stop button and the Reverse stitch button. The LCD shows the Factory Setting Mode. Press "Foot Sensor" key.
3. Turn the gear A (indicated with black arrow) with your hand to raise the presser foot.
4. Place a 13 mm thick spacer between the presser foot and the needle plate. Lower the presser foot on the spacer firmly by turning the gear A.
5. Be sure that the both Sensors 1 and Sensor 2 show "H". Press "Start" key on the touch panel.
 - * In case either Sensor 1 or Sensor 2 is not "H", turn the adjusting screw (indicated with white arrow) clockwise until the both Sensor 1 and Sensor 2 show "H".
6. Turn the adjusting screw counterclockwise until a beep sound and the "OK" message is shown.

Mechanical adjustment

Presser bar height

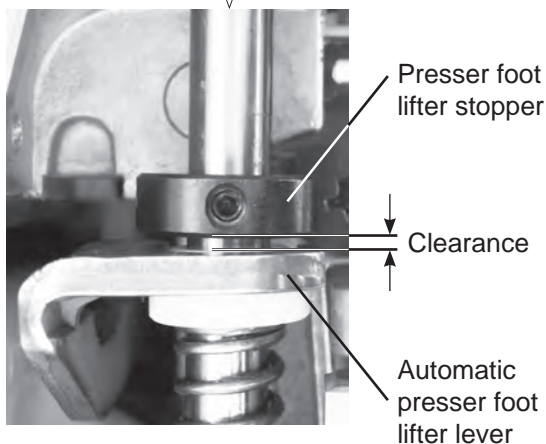
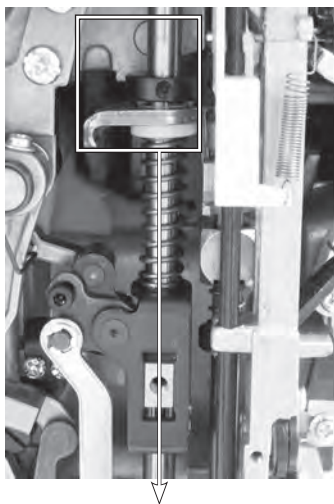
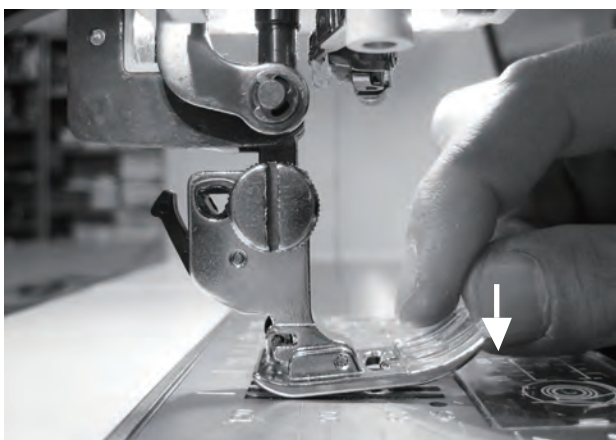
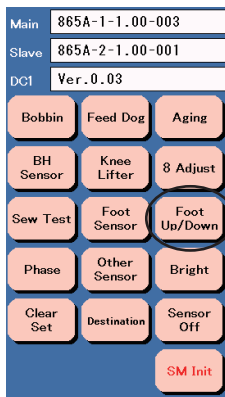

To adjust:

1. Turn the power switch ON while pressing the Start/ Stop button and the Reverse stitch button. The LCD shows the Factory Setting Mode. Press "Foot Up/Down" key.
 2. Attach the foot holder lightly (Do not tighten the thumbscrew.).
 3. Press "Down" key. The presser bar will be lowered. Tighten the thumbscrew firmly.
 4. Press "Init" key to initialize the settings. Press "Adjust" key to lower the foot.
There should be no gap between the foot and needle plate, but no pressure applied to the needle plate. Check it by tapping the toe of the foot with fingertip as shown.
 5. If there is a gap, press "+" key to lower the foot until the foot lands on the needle plate without the gap.
 6. If the foot depress the needle plate, press "-" key few times to raise the presser foot, then press "+" key to lower the foot until the foot lands on the needle plate without the gap.
- * Adjust the presser bar height always by pressing "+" key. Do not press "-" at the end of this adjustment.
 - * The value of "Adjust Step" should be within the range of 970 to 1030. If the value is far out of the range, check Automatic Presser Foot Lifter Sensor adjustment.
7. Turn the power switch ON again to enter the ordinary sewing mode, and set the presser foot pressure to "Auto-5". Press the presser foot button to lower the presser foot. Be sure that there is a clearance between the presser foot lifter stopper and the automatic presser foot lifter lever as shown in the picture.
- * If there is no clearance between the presser foot lifter stopper and the automatic presser foot lifter lever, adjust the presser bar height again.

Mechanical adjustment

Stretch stitch feed balance

Adjust the stretch stitch balance dial at the setting mark.

The measurement of five of test patterns should be in the range of 33 to 39 mm as shown.

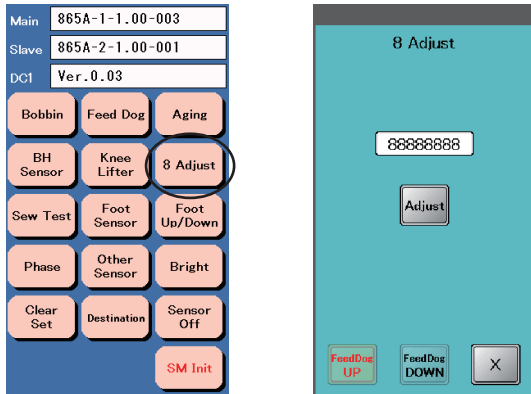

To adjust:

1. Turn the power switch ON while pressing the Start/ Stop button and the Reverse stitch button. The LCD shows the Factory Setting Mode. Press "8 Adjust" key.

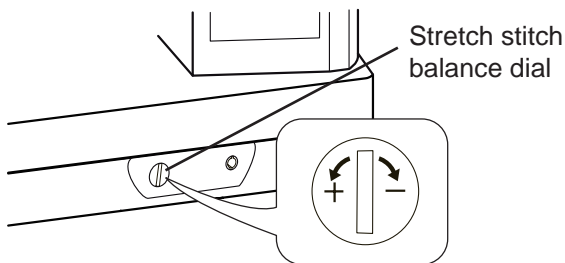

2. Set the stretch stitch balance dial vertical.

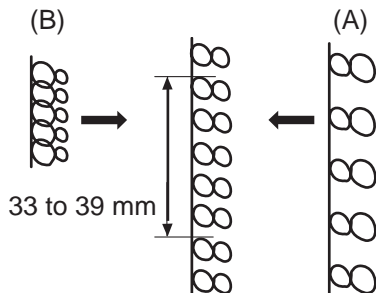

3. Attach the satin stitch foot (F). Sew test patterns and measure the length of the 5 patterns. The length should be 33 mm to 39mm.

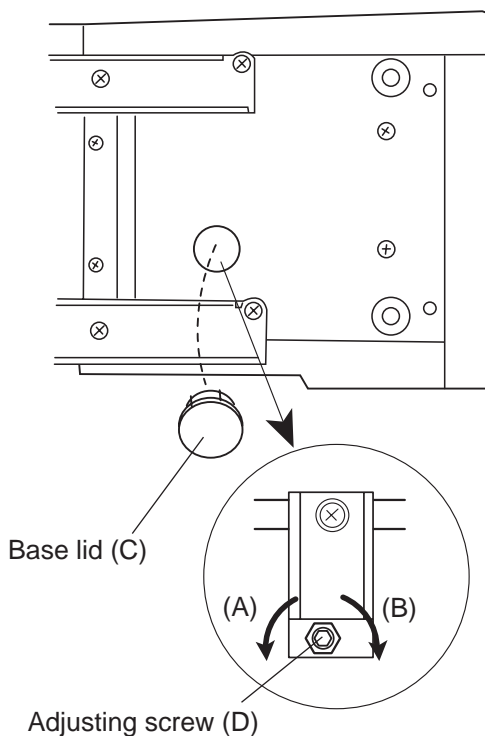

4. If not, remove the base lid C.
Press the "Adjust" key so the adjusting screw D comes to the adjusting position.

* Turn the adjusting screw in the direction of A if the length is more than 39 mm.

* Turn the adjusting screw in the direction of B if the length is less than 33 mm.

5. Sew the test pattern and measure the length of the 5 patterns.

6. Attach the base lid and turn the power switch OFF.

Mechanical Adjustment

Needle plate switch

Fig. 1

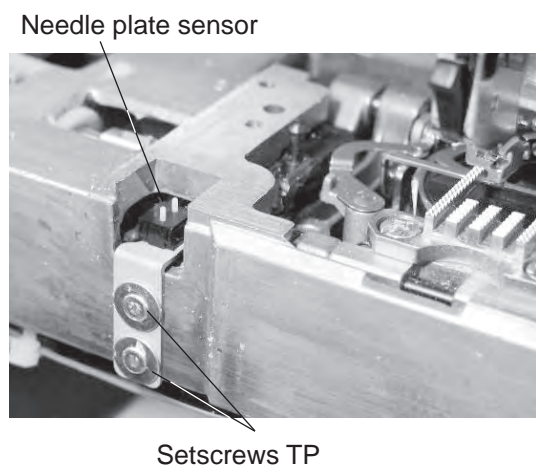

To check and adjustment:

1. Prepare the needle plate and the needle plate for straight stitch.
2. Insert the needle plate base plate under the fixed cutter spacer and the slide plate positioning plate. Press the  mark to attach the needle plate.
3. The distance between the bottom side of the needle plate and the micro switch base plate should be in the range of 11 – 11.5 mm.

If not, loosen the setscrews TP and move the base plate up or down to adjust it. Tighten the setscrews TP firmly after the adjustment.

The actuator of the micro switch should be aligned with the needle plate sensor knob as shown in fig 3.

Fig. 2

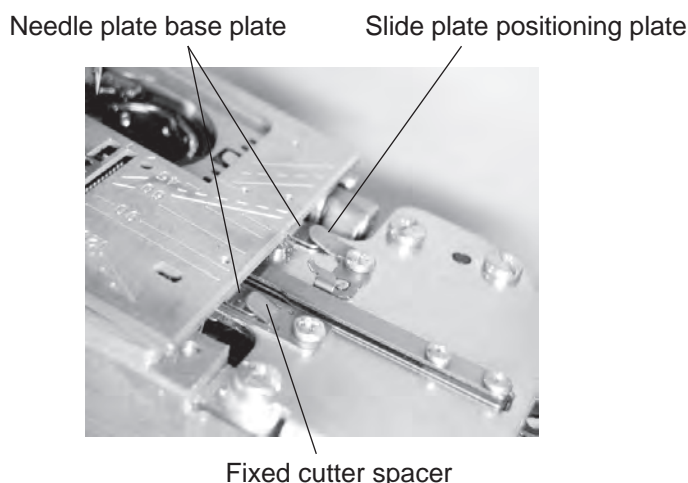

To remove:

1. Remove the base cover, bed cover and the free-arm cover (see page 3 to 5).
2. Disconnect the connector from the needle plate switch from the printed circuit board A (see page 10-11).
3. Remove the setscrews TP and the needle plate sensor switch.

To attach:

1. Attach the needle plate sensor switch with the setscrews TP. Tighten the setscrews TP lightly.
2. Connect the needle plate sensor switch connector to the printed circuit board A.
3. Check the needle plate sensor and adjust as necessary (see the adjustment procedure below).
4. Tighten the setscrews TP firmly.
5. Attach the base cover, bed cover and free-arm cover.

Fig. 3

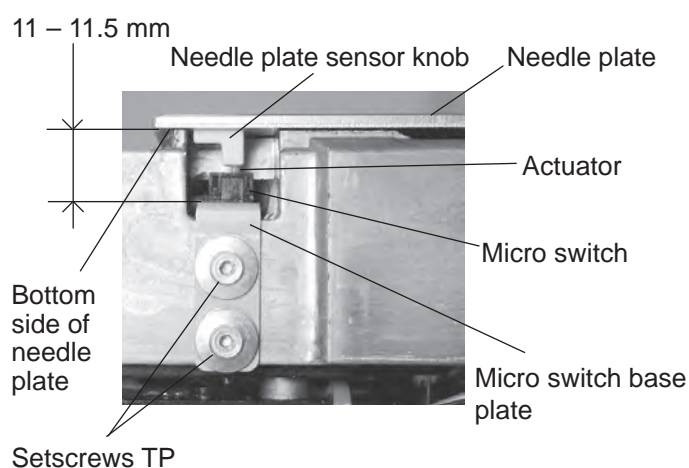

Mechanical adjustment

Knee lifter

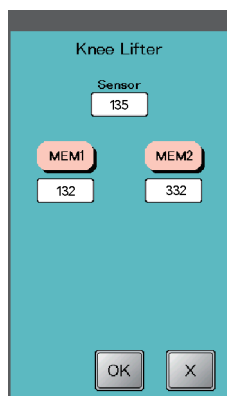
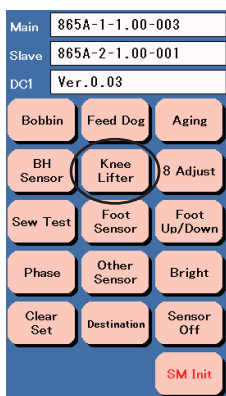

To adjust:

1. Turn the power switch ON while pressing the Start/ Stop button and the Reverse stitch button. The LCD shows the Factory Setting Mode. Press "Knee lifter" key.

Knee lifter is free.



2. Attach the knee lifter.
Press "MEM1" key when the knee lifter is free.

Push the knee lifter to the right as far as it goes.



3. Push the knee lifter to the right as far as it goes and press "MEM2" key.
4. Press "OK" key.