

Memory Craft 9500

Instruction book

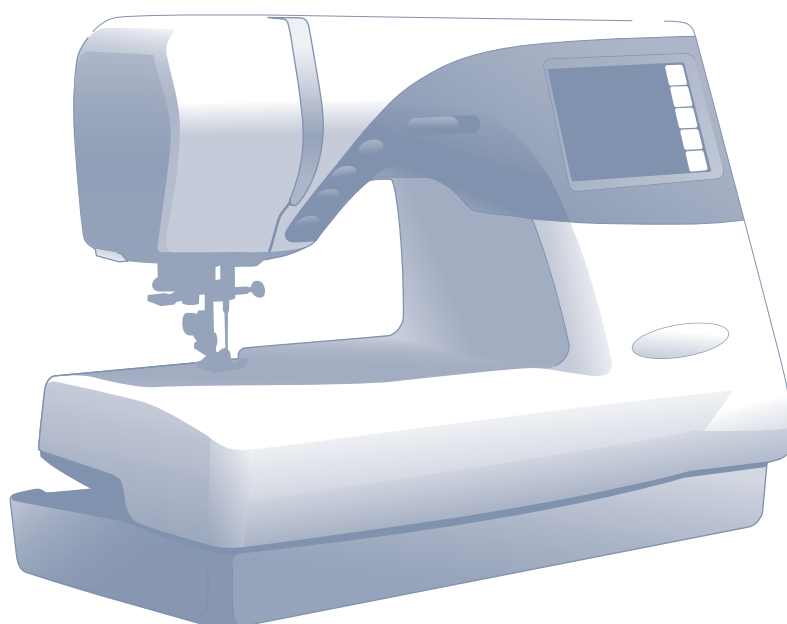

JANOME

TABLE OF CONTENTS

KNOW YOUR MACHINE	2	Shell Tuck Stitch	61
Name of Parts	2	Applique sewing	62
Standard Accessories and Storage	3	Programming French knot	63
Extension Table	5	Sewing the pattern combination from the beginning ...	64
		Individual pattern adjustment.....	65
GETTING READY TO SEW	6	Editing Programmed Patterns	66
Connecting the Power Supply	6	Program check	67
Function Buttons	7	Twin Needle Sewing	68
Controlling Sewing Speed	8	Monogramming	70
Raising and Lowering the Presser Foot	9	Programming a monogram	71
Removing and Attaching the Presser Foot	9	Saving and Opening a File	72
Various Presser Feet and Their Uses	11	Saving a file	72
Winding the Bobbin	12	Assigning a file name	73
Threading for bobbin winding	13	Correcting Distorted Stretch Patterns	74
Inserting the Bobbin	14		
Threading the Machine	15	EMBROIDERY MODE	75
Built-in Needle Threader	16	Embroidery Hoops	75
Drawing Up the Bobbin Thread	17	Stabilizers	76
Changing Needles	18	Adjusting the Thread Tension	76
Balancing Thread Tension	19	Pressure Dial	76
Adjusting the Foot Pressure	20	Setting the Fabric in an Embroidery Hoop	77
Dropping the Feed Dog	20	Attaching the Embroidery Hoop to the Machine	78
Mode Selection	21	Mode Selection	79
		Built-in Designs	80
SETTING MODE	22	Starting to Sew Embroidery	82
Language Selection	25	Monogram Embroidery	83
		Monogram in gothic style	85
ORDINARY SEWING	26	2- Letters monogram	87
Pattern Selection	26	Correcting a monogram	88
Utility Stitches	27	PC Card Designs	89
Straight stitch	27	Card Reader 100000	90
Adjusting the needle drop position and stitch length ..	29	Editing Mode	91
Variety of straight stitches	31	Selecting the pattern to edit	92
Zigzag stitch	32	Moving a pattern	93
Changing stitch width	33	Selecting the hoop	93
Changing stitch length	33	Resizing a pattern	94
Overcasting with zigzag stitch	34	Flipping a pattern	94
Variety of overcasting stitches	35	Deleting a pattern	94
Blind hem stitch	36	Magnifying a pattern image	94
Zipper sewing	38	Saving a File	95
Quilting	41	Assigning a file name	96
Variety of buttonholes and their uses	42	Combining a built-in design and monogram	97
Sensor buttonhole	43	Opening a Saved File	99
Corded buttonhole	46	On-screen Help	100
Changing buttonhole width	47		
Changing buttonhole stitch density	47	CARE AND MAINTENANCE	101
Automatic buttonhole	48	Cleaning the Hook Race and Feed Dog	101
Button sewing	50	Replacing the Light Bulb	102
Darning	51	Troubleshooting	103
Tacking	53		
Eyelet	54	STITCH CHART	105
Basting	55		
Satin Stitches	56	DESIGN CHART	106
Single pattern with locking stitch	58		
Programming a pattern combination	58		
Elongation sewing	59		
Programming a pattern combination with a mirror image ...	60		
Decorative Stitches	61		

KNOW YOUR MACHINE

Name of Parts

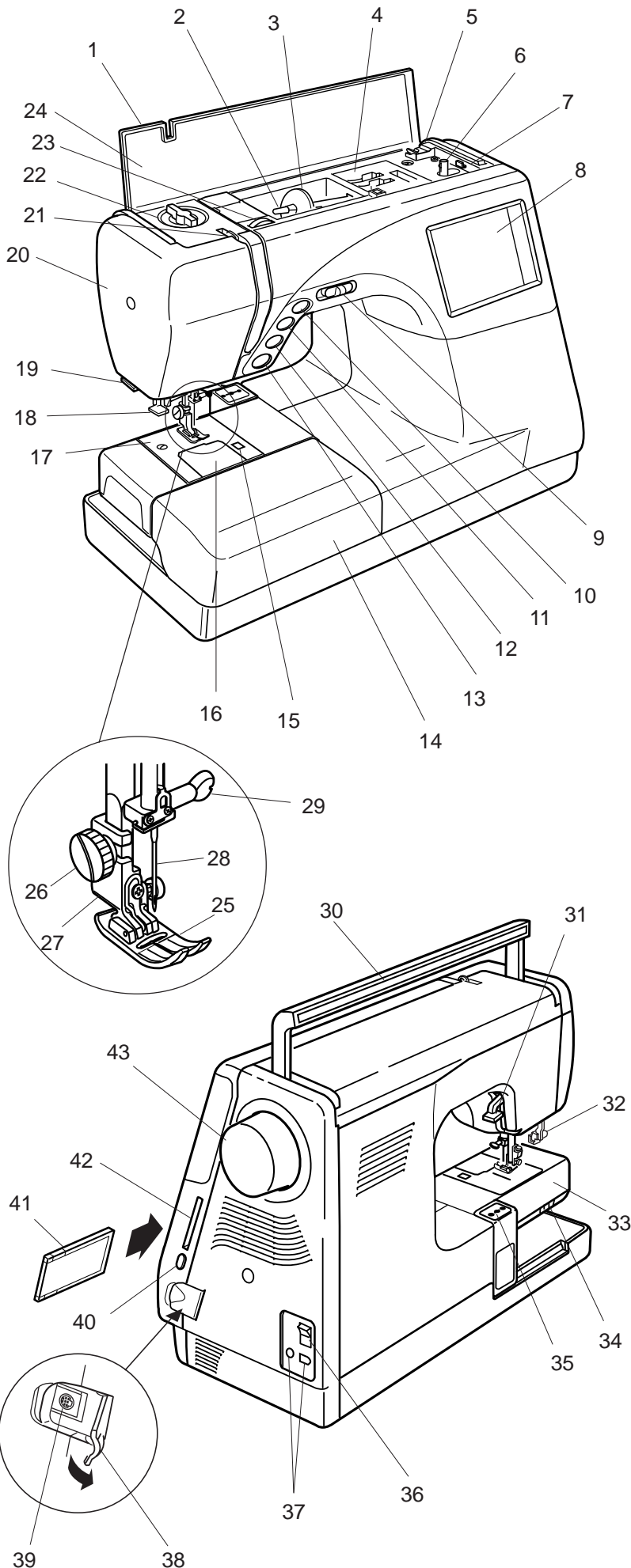

1. Top Cover
2. Spool Pin
3. Spool Holder (Large)
4. Foot Storage Compartment
5. Bobbin Thread Cutter
6. Bobbin Winder Spindle
7. Bobbin Winder Stopper
8. Visual Touch Screen
9. Speed Control Lever
10. Up/Down Needle Button
11. Auto-Lock Button
12. Reverse Button
13. Start/Stop Button
14. Extension Table (Accessory Box)
15. Hook Cover Plate Release Button
16. Hook Cover Plate
17. Needle Plate
18. Built-in Needle Threader
19. Thread Cutter & Thread Holder
20. Face Plate
21. Thread Take-up Lever
22. Pressure Dial
23. Thread Tension Dial
24. Flip-Top Quick Reference Chart
25. Zigzag Foot A
26. Thumb Screw
27. Foot Holder
28. Needle
29. Needle Clamp Screw
30. Carrying Handle
31. Presser Foot Lifter
32. Buttonhole Lever
33. Free Arm
34. Drop Feed Lever
35. Carriage (for Embroidery)
36. Power Switch
37. Machine Sockets
38. Connector Cover
39. RS-232C Connector
40. Card Eject Button
41. PC Design Card (Optional item)
42. PC Card Slot
43. Handwheel

Standard Accessories and Storage

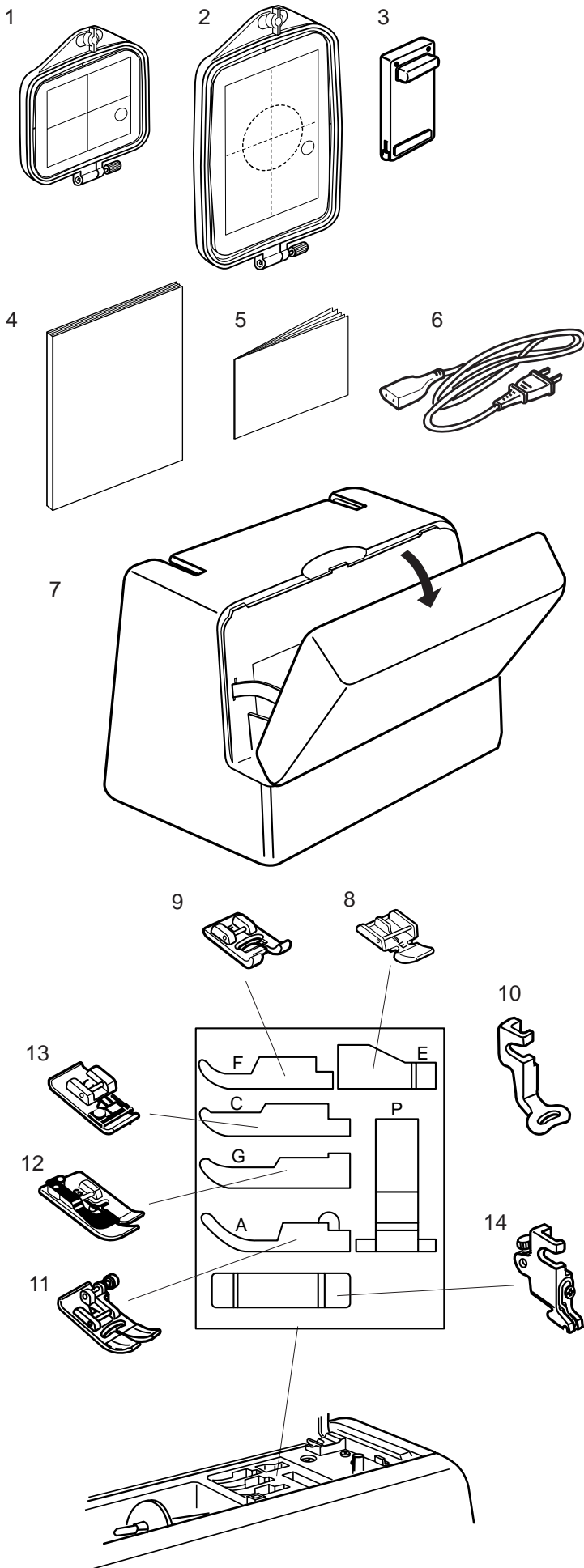

1. Embroidery Hoop **(A)** (with Template)
2. Embroidery Hoop **(B)** (with Template)
3. Foot Control

4. Instruction Book
5. Template Sheets (for Built-in Designs)
6. Power Supply Cord
7. Hard Cover (Carrying Case)

8. Zipper Foot **E**
9. Satin Stitch Foot **F**
10. Embroidery Foot **P**
11. Zigzag Foot **A** (comes attached to the machine)
12. Blind Hem Foot **G**
13. Overedge Foot **C**
14. Foot Holder (comes attached to the machine)

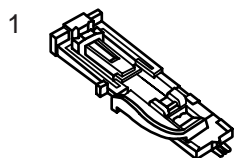

1

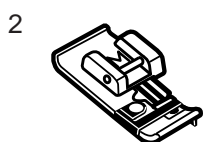

2

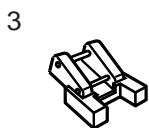

3

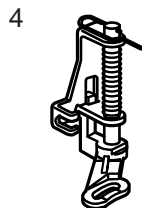

4

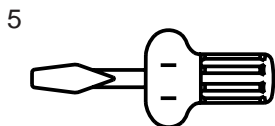

5



6

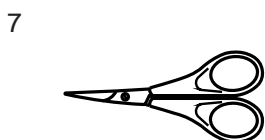

7

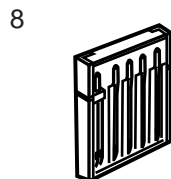

8



9



10

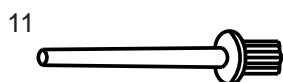

11

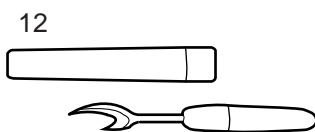

12

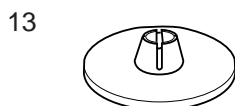

13



14

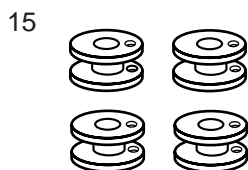

15

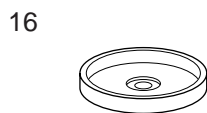

16

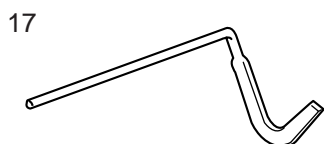

17

1. Automatic Buttonhole Foot **R**

2. Overcasting Foot **M**

3. Button Sewing Foot **T**

4. Basting/Darning Foot **P-2**

5. Screwdriver

6. Screwdriver

7. Scissors

8. Set of Needles

9. Spool Pin Felt

10. Lint Brush

11. Additional Spool Pin

12. Seam Ripper

13. Spool Holder (Large)

14. Spool Holder (Small)

15. Bobbins

16. Spool Stand

17. Quilting Bar

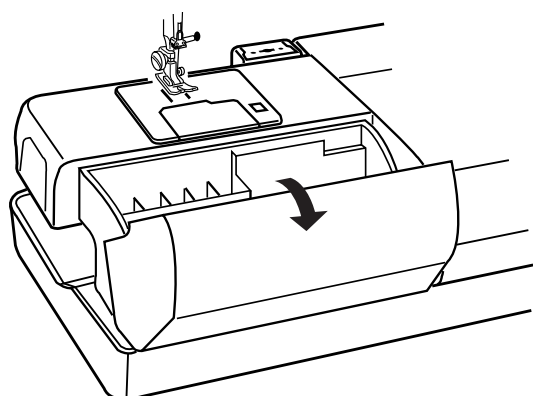

Detachable extension table for accessory storage
Sewing accessories are stored in the Extension Table.
To open, lift the cover toward you as illustrated.

Extension Table

For free arm sewing

To remove, lift out the Extension Table toward you as illustrated.

1 Extension Table

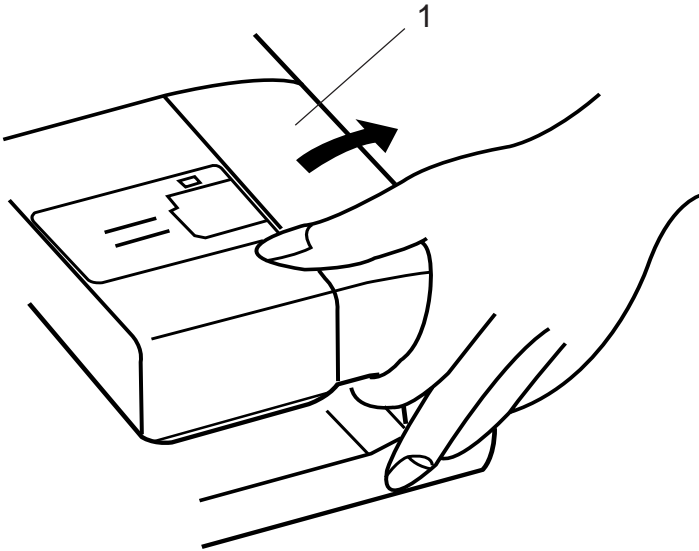

Free Arm sewing is suitable for:

- stitching sleeves, waistbands, pants legs or any circular garment area.
- darning socks or mending knees, elbows or children's wear.

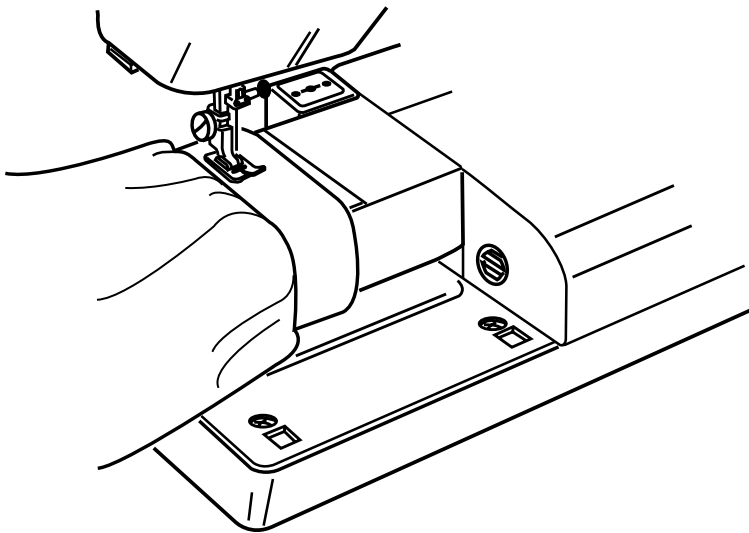

For flat-bed sewing

Position the Tabs on the Base Tab Holes and push down gently.

2 Tabs

3 Base Tab Holes

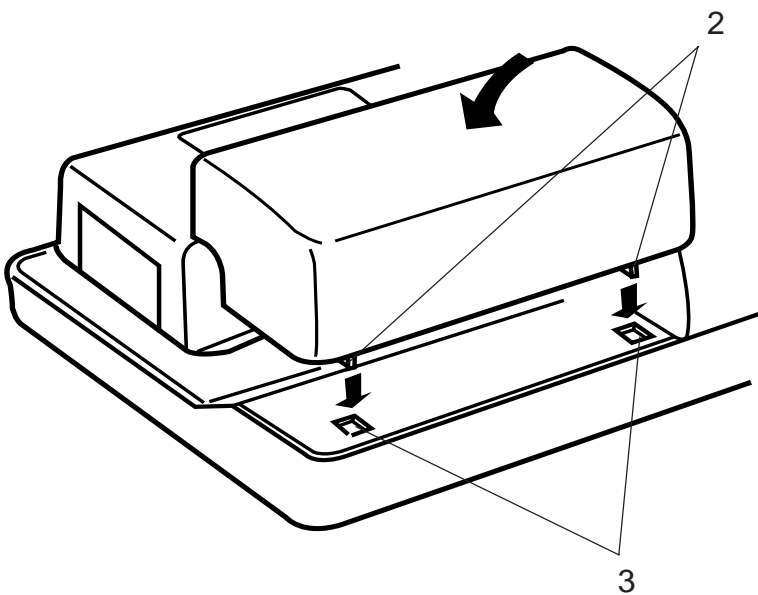

GETTING READY TO SEW

Connecting the Power Supply

The Memory Craft 9500 is equipped with an auto voltage system, which automatically adjusts the equipment to any local power supply voltage between 100 and 240V, 50/60 Hz.

First, turn off the Power Switch. Then insert the Foot Control Plug and Machine Plug into the Machine Socket. Next, insert the Power Supply Plug into the Wall Outlet and turn on the Power Switch.

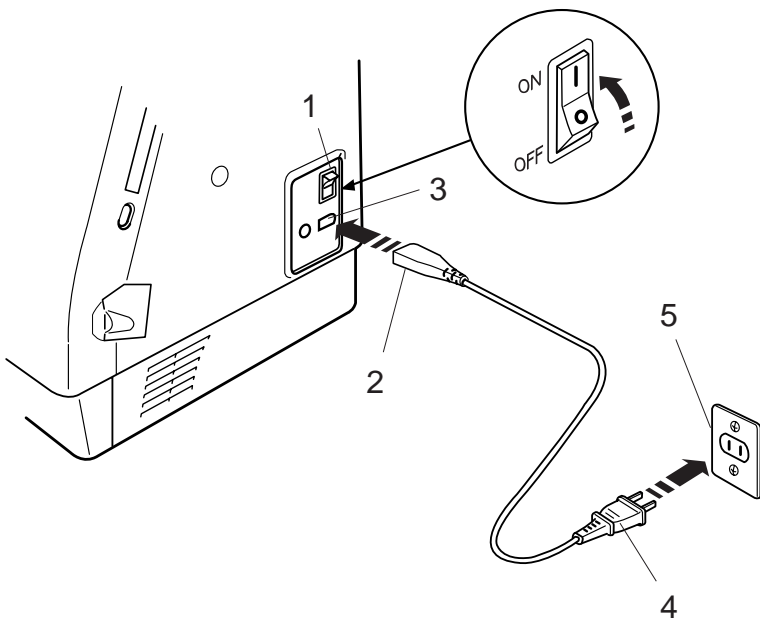

- 1 Power Switch
- 2 Machine Plug
- 3 Machine Socket
- 4 Power Supply Plug
- 5 Wall Outlet
- 6 Foot Control Plug

NOTES:

Make sure to use the Power Supply Cord that came with the machine.

If you turn off the power switch, wait for 5 seconds before turning it on again.

The Foot Control cannot be used in the Embroidery Mode.

For Your Safety:

While in operation, always keep your eyes on the sewing area, and do not touch any moving parts such as the thread take-up lever, handwheel or needle. Always turn off the Power Switch and unplug the machine from the power supply:

- when leaving the machine unattended.
- when attaching or removing parts.
- when cleaning the machine.

Do not place anything on the Foot Control.

Operating Instructions:

The symbol "O" of a switch indicates the "off" position of a switch."

For appliances with a polarized plug (one blade wider than the other). To reduce the risk of electric shock, this plug is intended to fit in a polarized outlet only one way. If it does not fit fully in the outlet, reverse the plug. If it still does not fit, contact a qualified electrician to install the proper outlet. Do not modify the plug in any way."

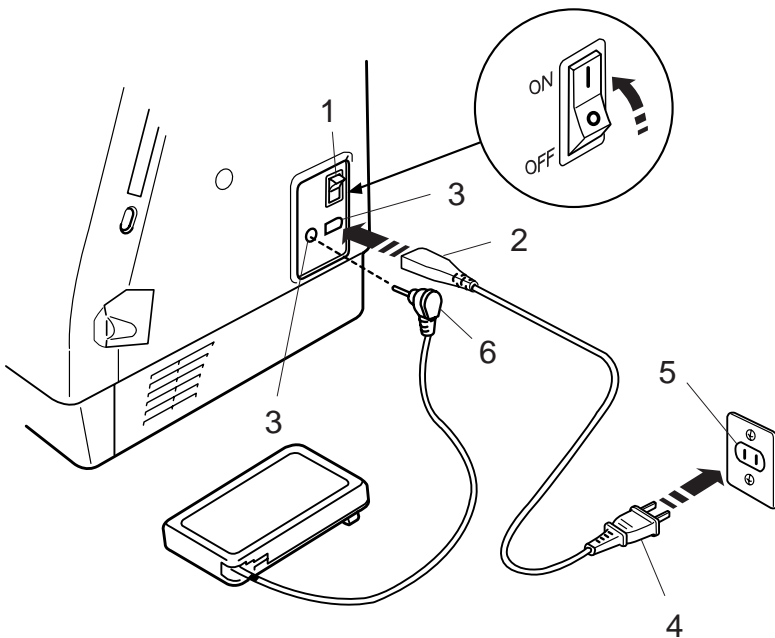

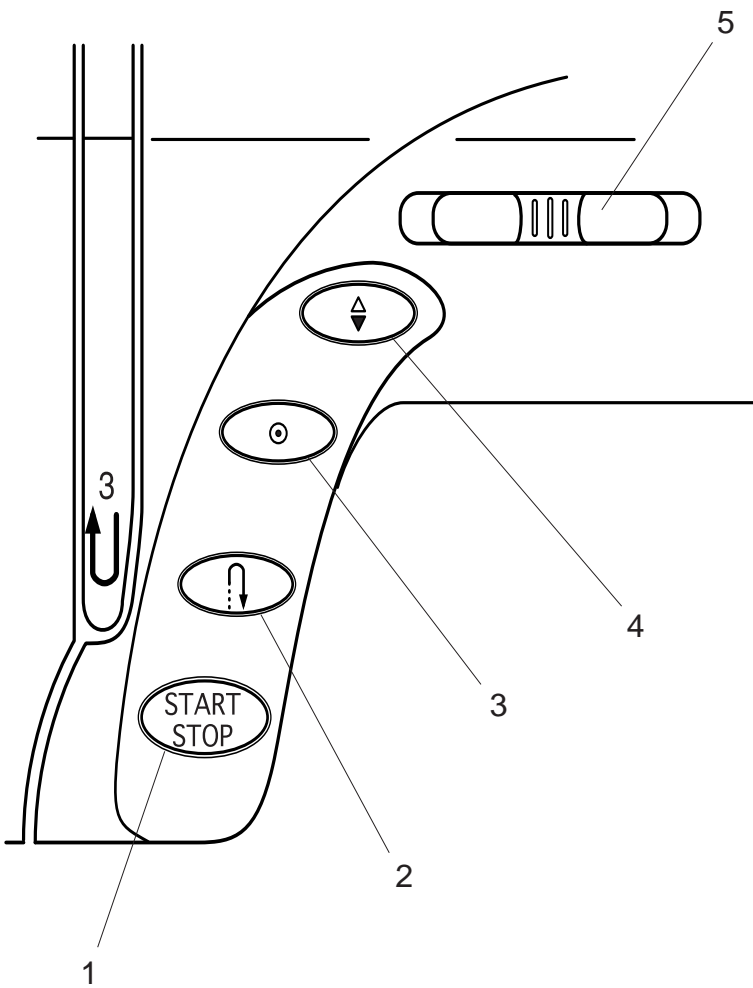

Function Buttons

1 Start/Stop Button

Press this button to start or stop the machine. This button can be used either in the Ordinary Sewing Mode or Embroidery Mode. In the Ordinary Sewing Mode, the machine starts running slowly for the first few stitches, it then runs at the speed set by the Speed Control Lever.

NOTE:

The Start/Stop Button cannot be used when the foot control is connected to the machine.

2 Reverse Button

When stitch pattern 1, 2, 6 or 7  has been selected, the machine will sew in reverse while the Reverse Button is being pressed.

If you press the Reverse Button when sewing all other stitches, the machine will immediately sew locking stitches and automatically stop.

3 Auto-Lock Button

When stitch pattern 1, 2, 6 or 7  has been selected, the machine will immediately sew locking stitches and automatically stop when the Auto-Lock Button is pressed.

When sewing all other stitches, the machine will sew locking stitches at the end of the current pattern and automatically stop.

4 Up/Down Needle Button

Press this button to bring the needle bar up or down.

5 Speed Control Lever

See page 8.

Controlling Sewing Speed

Speed Control Lever

You can limit the maximum sewing speed with the Speed Control Lever according to your sewing needs. To increase the sewing speed, slide the lever to the right.

To decrease the sewing speed, slide the lever to the left.

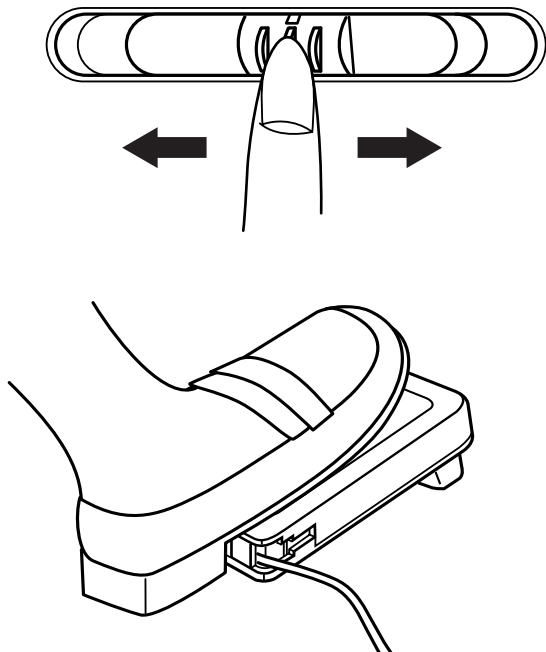

Foot Control

Pressing on the Foot Control can vary sewing speed. The harder you press the Foot Control, the faster the machine runs.

NOTE:

The machine runs at the maximum speed set by the Speed Control Lever when the foot control is fully depressed.

Operating Instructions:

Foot controller Model 21371 is for use with sewing machine model MC9500.

NOTE:

The Memory Craft 9500 is equipped with an automatic shutdown safety feature to prevent overheating whenever the machine is running overloaded. Follow the safety instructions that appear on the Visual Touch Screen.

Raising and Lowering the Presser Foot

The Presser Foot Lifter raises and lowers the Presser Foot.

You can raise the Presser Foot about 6 mm (1/4") higher than the normal up position by exerting more pressure when lifting the Presser Foot Lifter. This allows for easy removal of the Presser Foot and helps you to place thick fabrics under it.

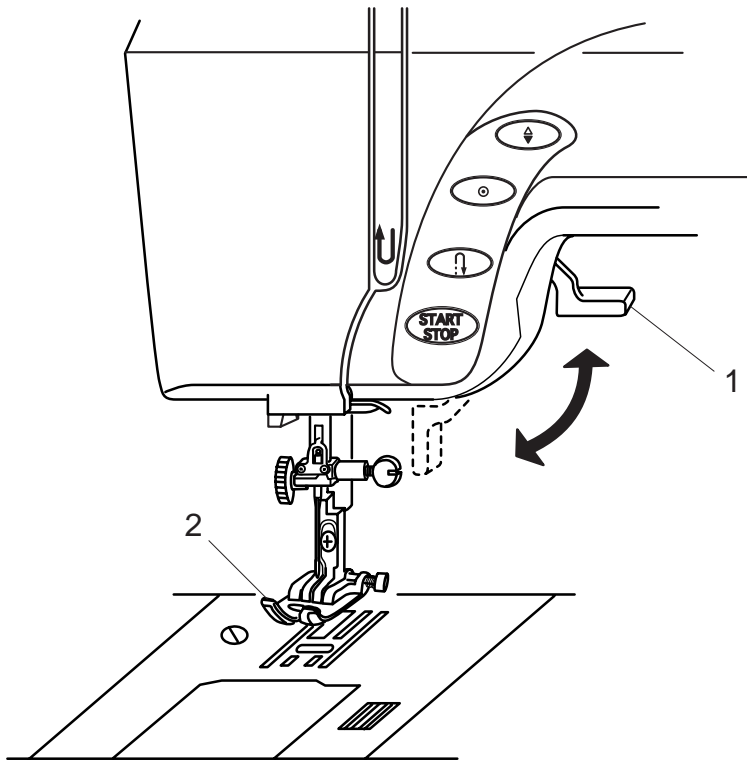

- 1 Presser Foot Lifter
- 2 Presser Foot

Removing and Attaching the Presser Foot

Removing the presser foot

Press the Up/Down Needle Button to raise the needle to its highest position and raise the Presser Foot Lifter. Press the Red Button on the back of the foot holder. The Presser Foot will drop off.

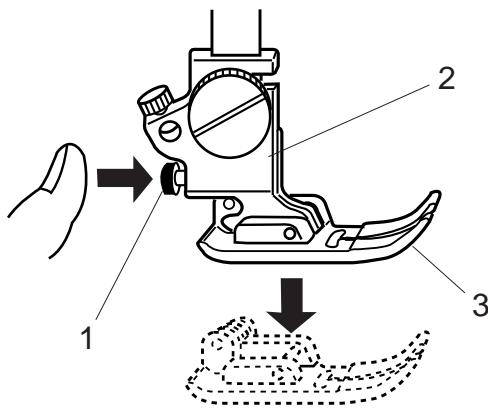

Attaching the presser foot

Place the selected Presser Foot so that the pin on the foot lies just under the Groove of the Foot Holder. Lower the Presser Bar to lock the foot in place.

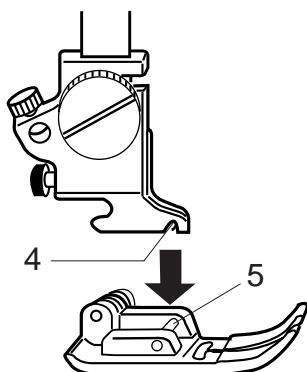

- 1 Red Button
- 2 Foot Holder
- 3 Presser Foot
- 4 Groove of Foot Holder
- 5 Pin on Foot

Button Sewing Foot T

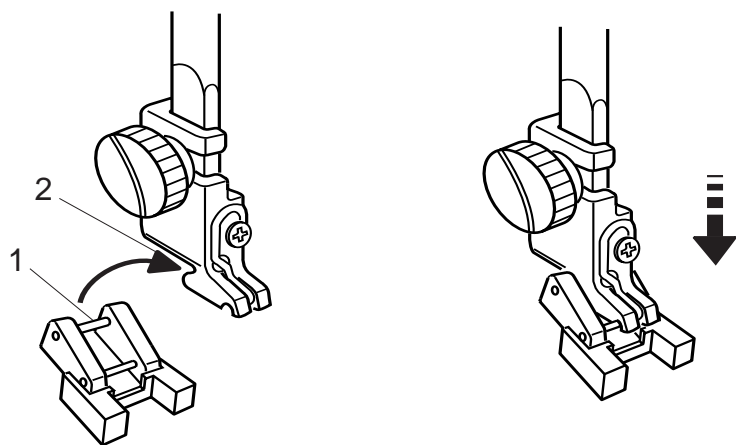

To Attach:

Insert the Rear Pin on the foot into the Groove of the Foot Holder.

Gently lower the presser bar, holding the foot with your fingers.

- 1 Rear Pin
- 2 Groove of the Foot Holder

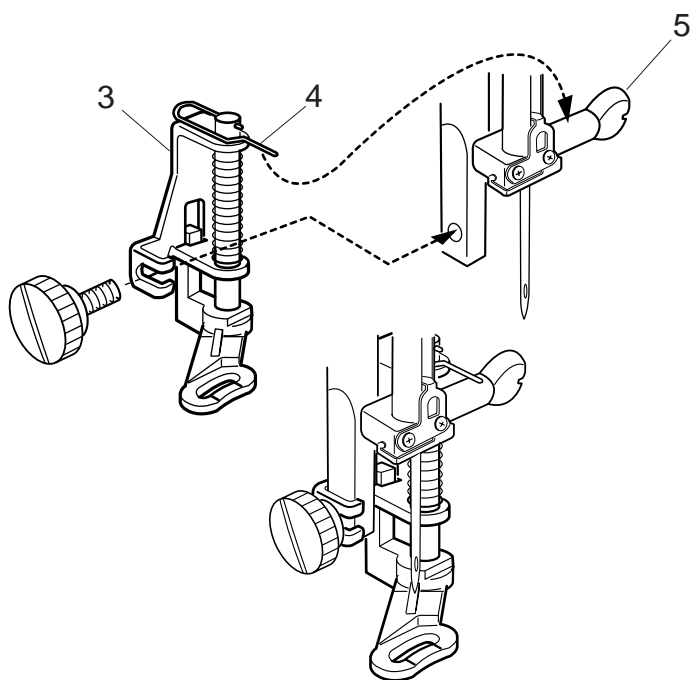

Darning Foot P-2

To Attach:

Loosen the thumb screw and remove the Foot Holder.

Attach the Darning Foot **P-2** to the presser bar putting the Pin on the Needle Clamp Screw.

Tighten the thumb screw firmly with the screwdriver.

- 3 Darning Foot **P-2**
- 4 Pin
- 5 Needle Clamp Screw

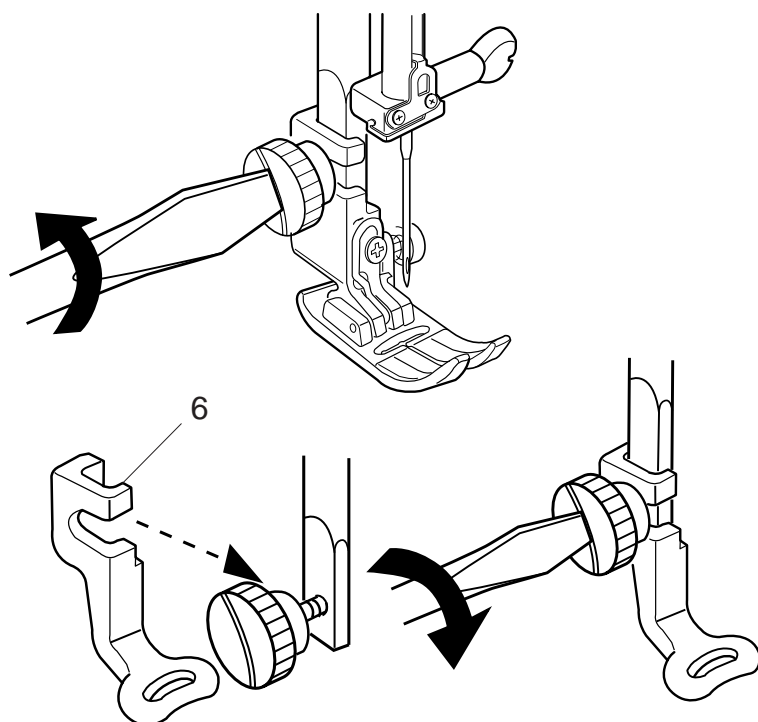

Embroidery Foot P

To Attach:

Loosen the thumb screw and remove the Foot Holder to the rear.

Attach Embroidery Foot **P** to the presser bar from behind.

Tighten the thumb screw securely with the screwdriver.

- 6 Embroidery Foot **P**

Various Presser Feet and Their Uses

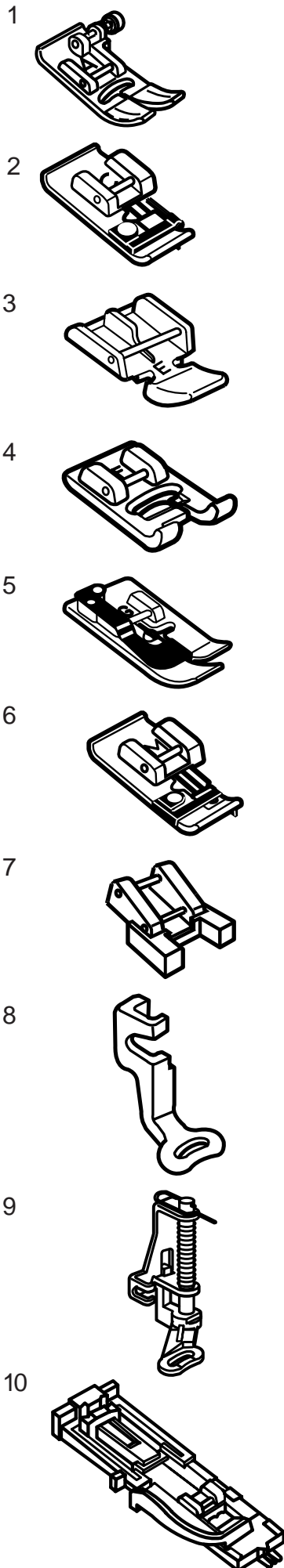

1 Zigzag Foot A:

This is the most versatile foot. It can be used for various stitches including straight stitches and zigzag stitches. It is designed to achieve firm and neat seam results.

2 Overedge Foot C:

This foot is exclusively for overedging. The brush on the foot effectively prevents skipped stitches on the raw edge of fabrics.

3 Zipper Foot E:

This foot is for sewing zippers. The zipper teeth are guided through the grooves on the bottom of the foot.

4 Satin Stitch Foot F:

This clear plastic foot is ideal for satin stitches and decorative stitches. The center groove on the bottom of the foot ensures smooth feeding of dense stitches.

5 Blind Hem Foot G:

This foot is specially designed for blind hemming. The guide on the foot helps feed the fabric and sew a straight and nearly invisible blind-hem.

6 Overcasting Foot M:

This foot is specially designed to simulate professional style overlocking. The wires on the foot effectively prevent the fabric edge from puckering or rolling.

7 Button Sewing Foot T:

This foot is exclusively used for attaching a button. It holds a button securely in place and allows fine adjustment of the button position.

8 Embroidery Foot P:

This foot is a special foot for Professional-Style Embroidery.

9 Basting/Darning Foot P-2:

This is a special foot for basting. It holds fabrics while taking a stitch, synchronizing with the needle bar movement. This foot can also be used for freehand embroidery or quilting.

10 Automatic Buttonhole Foot R:

This foot is for sensor buttonholes and for darning. Place a button in the button holder in the rear of the foot. This automatically sets the buttonhole size.

Winding the Bobbin

Removing the bobbin

- 1 Slide the Hook Cover Plate Release Button to the right, and remove the Hook Cover Plate.

- 1 Hook Cover Plate Release Button
- 2 Hook Cover Plate

- 2 Lift out the Bobbin from the Bobbin Holder.

- 3 Bobbin

Setting the Spool of Thread

Lift up the Spool Pin. Place the spool of thread on the Spool Pin with the thread coming off the spool as shown. Attach the Large Spool Holder, and press it firmly against the spool of thread.

NOTE:

Use the Small Spool Holder to hold narrow or small spools of thread.

Additional Spool Pin

Use the Additional Spool Pin when you need to wind the bobbin without unthreading the machine while working on a sewing project.

Insert the Additional Spool Pin into the Spool Stand and then into the Hole beside the horizontal spool pin. Place the Felt on the spool pin and place a spool of thread on it as shown.

- 4 Additional Spool Pin
- 5 Felt
- 6 Hole
- 7 Spool Stand

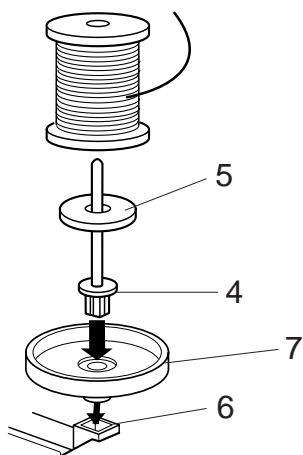
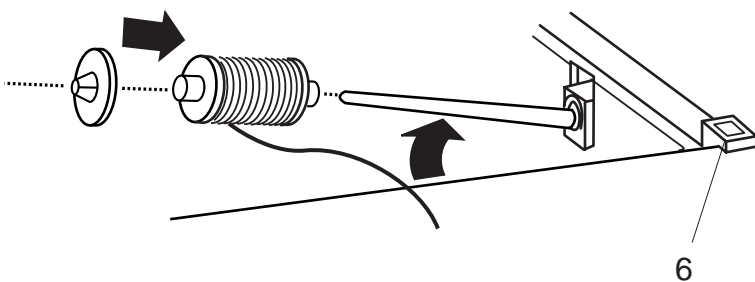
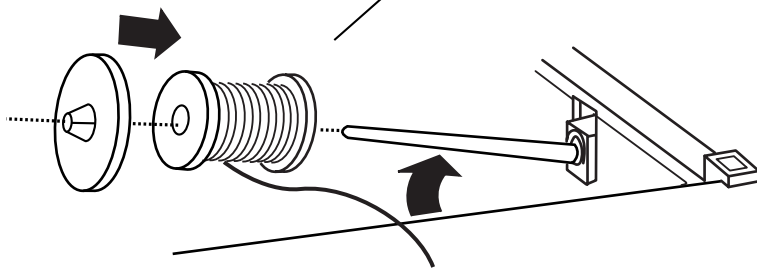
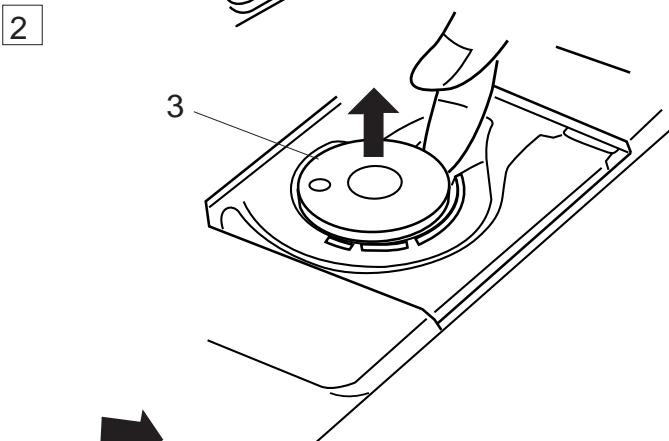
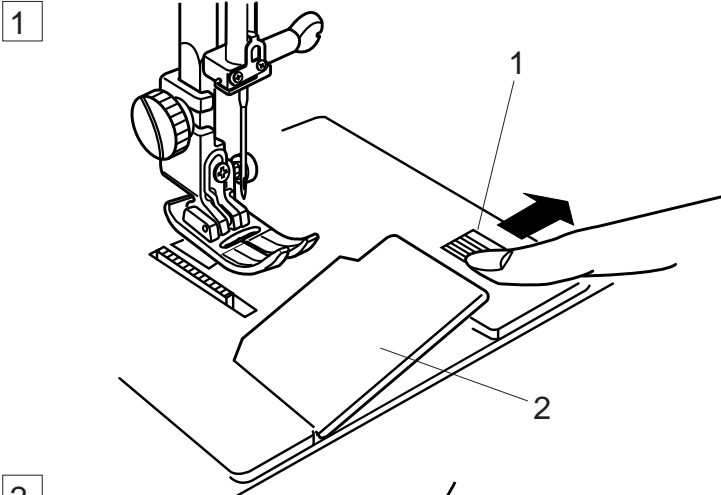

Threading for bobbin winding

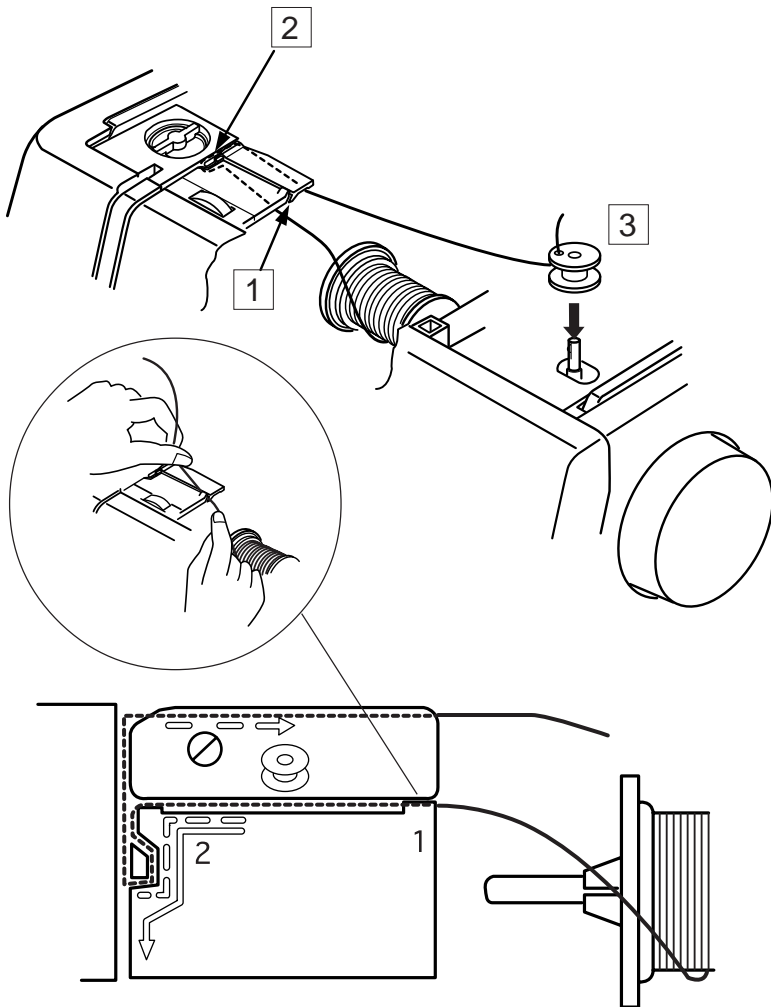

1 Hold the upper thread with both hands and place it down into the Slit.

2 Guide the thread around the Thread Guide following the dashed line as shown in the diagram.

3 Thread through the hole in the Bobbin from the inside to the outside. Put the Bobbin on the Bobbin Winder Spindle.

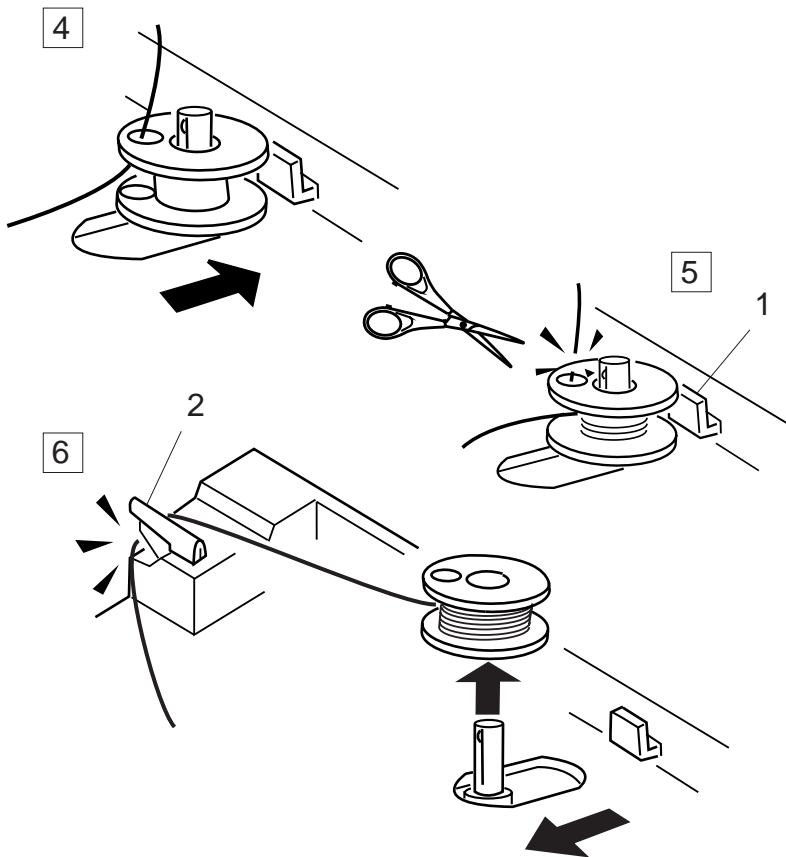

4 Push it to the right.

5 Hold the free end of the thread in your hand and depress the foot control. Stop the machine after the bobbin has made several turns, and cut the thread close to the hole in the bobbin.

6 Depress the Foot Control again. When the Bobbin is fully wound, it will stop automatically. Release the Foot Control and return the Bobbin Winder Spindle to its original position by moving it to the left, and cut the thread with the Bobbin Thread Cutter as shown.

1 Bobbin Winder Stopper

2 Bobbin Thread Cutter

NOTES:

The machine will not sew until the spindle has been returned to the left.
 You can use either the Foot Control or the Start/Stop Button to wind the Bobbin.
 For safety purposes, the machine will stop automatically 1.5 minutes after starting bobbin winding.

1

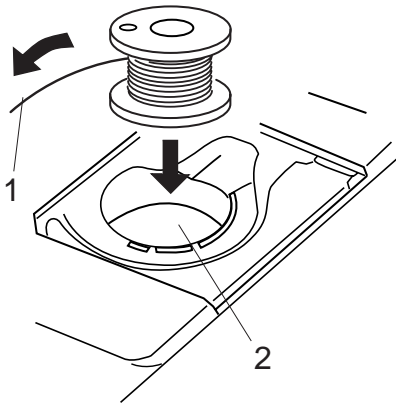

2

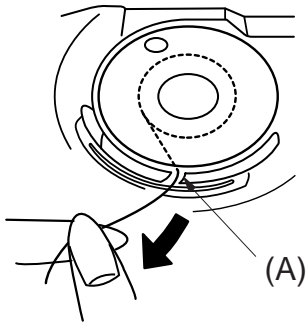

3

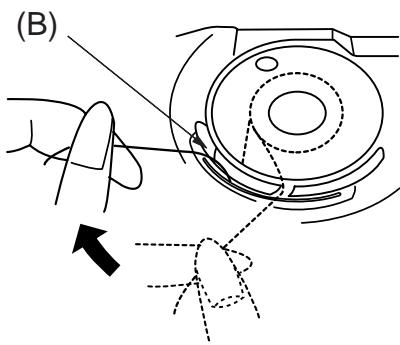

4

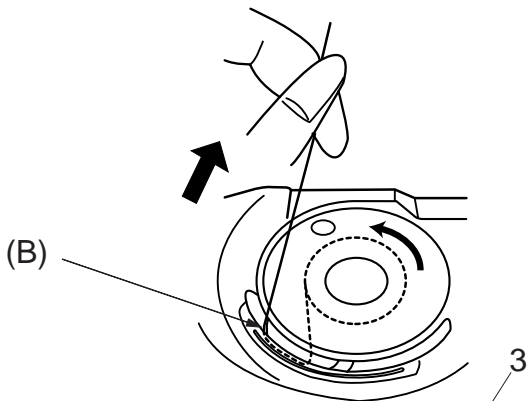

5

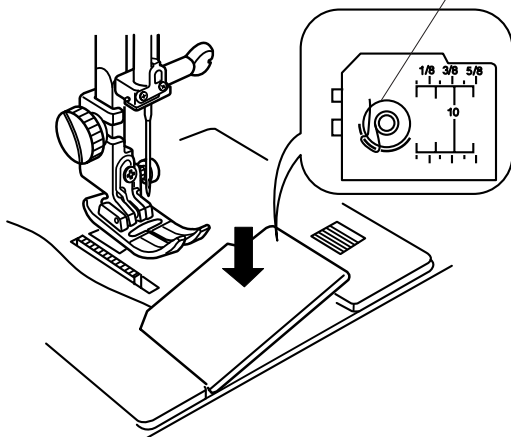

Inserting the Bobbin

1 Place the Bobbin in the Bobbin Holder with the Thread running off counterclockwise.

- 1 Thread
- 2 Bobbin Holder

2 Guide the thread into the Front Notch (A) on the front of the Bobbin Holder.

3 Draw the thread to the left, sliding it between the tension spring blades.

4 Continue to draw the thread lightly until the thread slips into the Side Notch (B).

5 Pull out about 10 cm (4") of thread to the rear.

NOTE:

A Threading Chart is shown on the Hook Cover Plate for your reference.

Reattach the Hook Cover Plate.

- 3 Threading Chart

Threading the Machine

Raise the Presser Foot Lifter. Press the Up/Down Needle Button twice to raise the needle to its highest position.

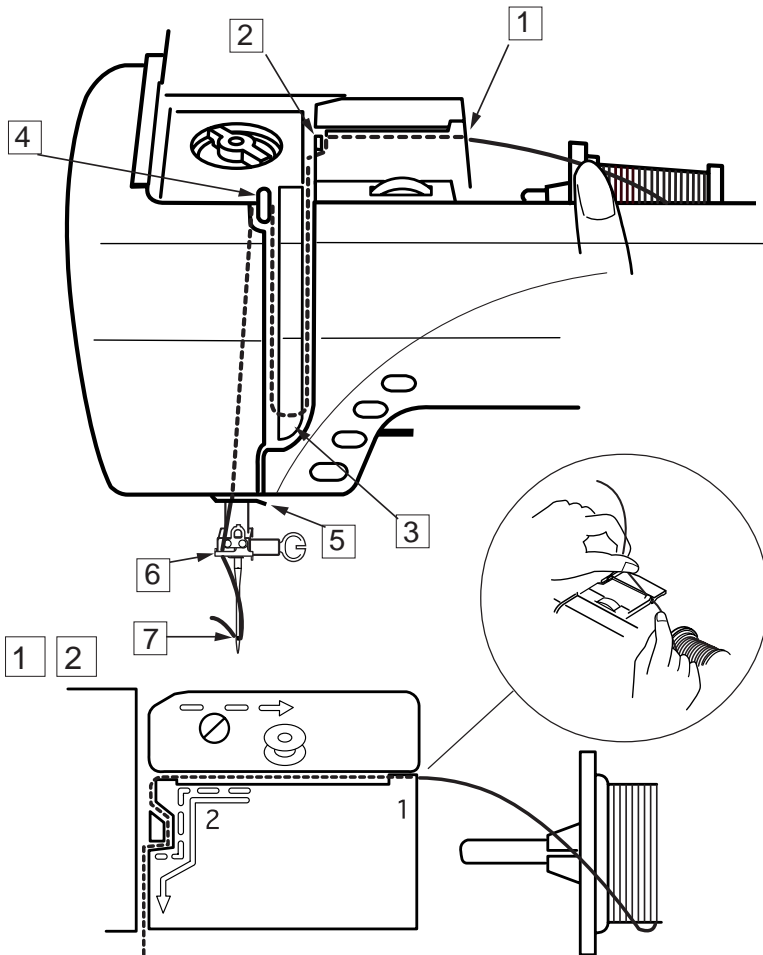

1 Hold the upper thread with both hands as shown and place it down into the Slit.

2 Draw the thread around the Thread Guide following the dashed line as shown in the diagram.

3 Then draw the thread down around the Check Spring Holder.

4 Firmly draw the thread up to the Take-up Lever and down into its eye from the right to the left.

5 Then down through the Lower Thread Guide.

6 Slide the thread behind the Needle Bar Thread Guide on the left.

7 Thread the needle from front to back by hand or use the Built-in Needle Threader.

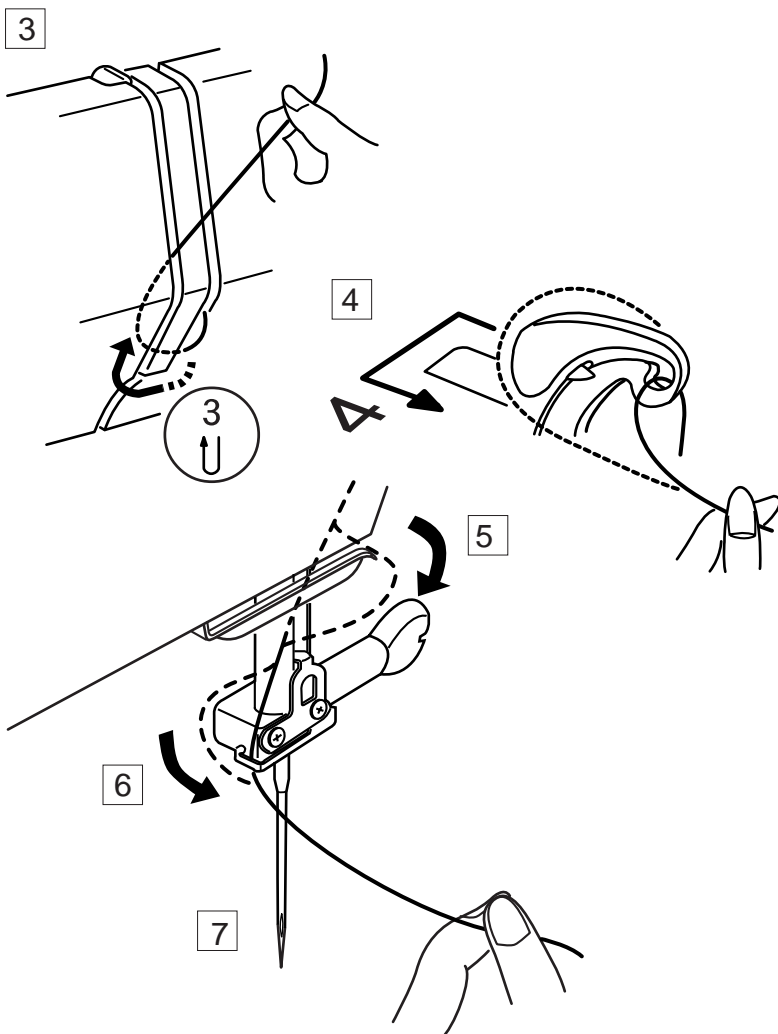

1 2 3

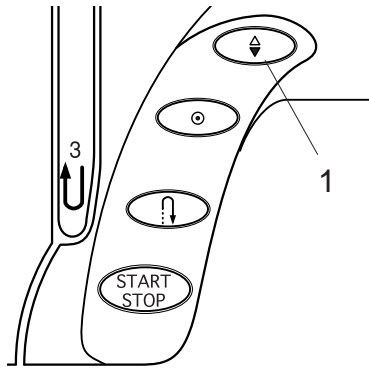

4

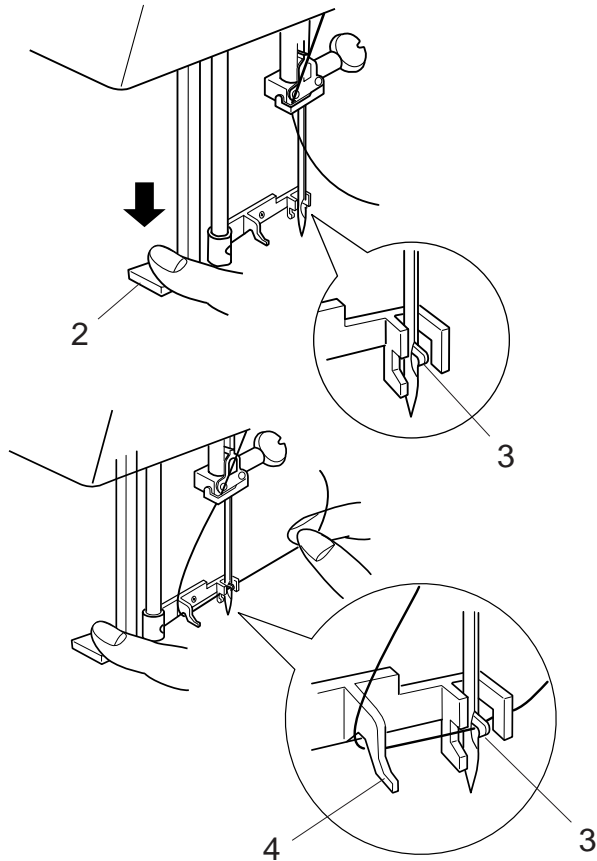

5

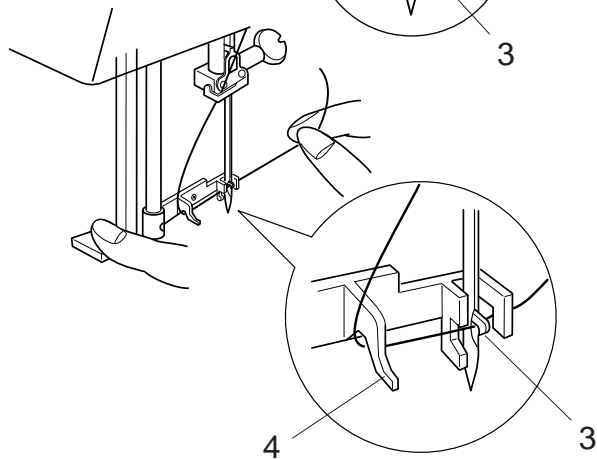

6

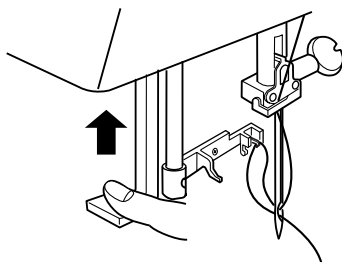

7

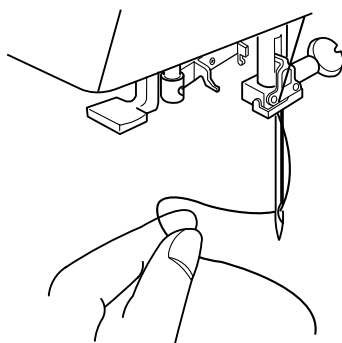

Built-in Needle Threader

- 1 Raise the needle to its highest position by pressing the Up/Down Needle Button twice.
- 2 Turn the power switch off.
- 3 Lower the presser foot.
- 4 Depress the Needle Threader Knob as far as it will go. The hook comes out through the needle eye from behind.

- 1 Up/Down Needle Button
- 2 Needle Threader Knob
- 3 Hook

- 5 Draw the thread down around the Threader Guide and under the hook.

- 4 Threader Guide

- 6 Release the threader knob slowly while holding the thread end with your hand. A loop of the thread is pulled up through the needle eye.

- 7 Remove the loop from the threader and pull out the thread end from the needle eye.

NOTES:

The automatic threader works well with the threads #50-100 and needles #11-16, the blue tipped needle as well.

Drawing Up the Bobbin Thread

1 Raise the Presser Foot Lifter.

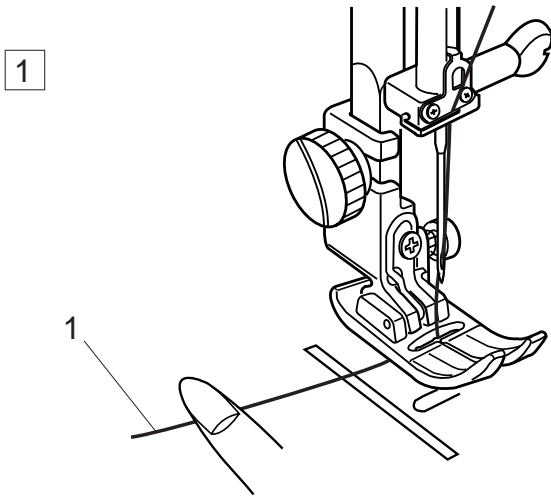

2 Hold the needle thread with your fingers and press the Up/Down Needle Button twice to pick up the bobbin thread. Draw up the needle thread to bring up a loop of the Bobbin Thread.

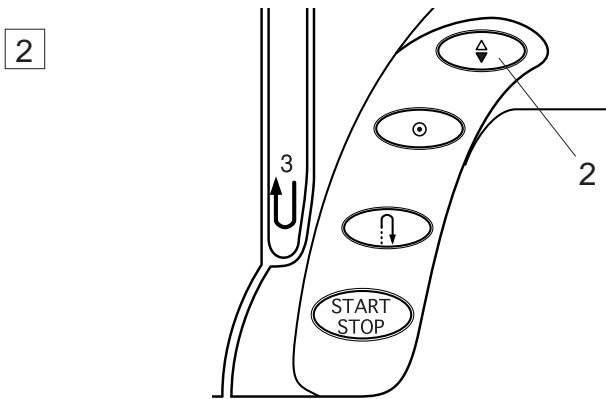

- 1 Needle Thread
- 2 Up/Down Needle Button
- 3 Bobbin Thread

3 Slide 10 cm (4") of both threads to the back under the presser foot.

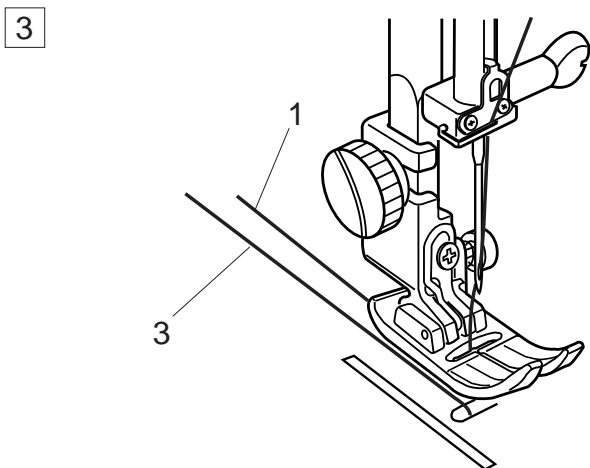
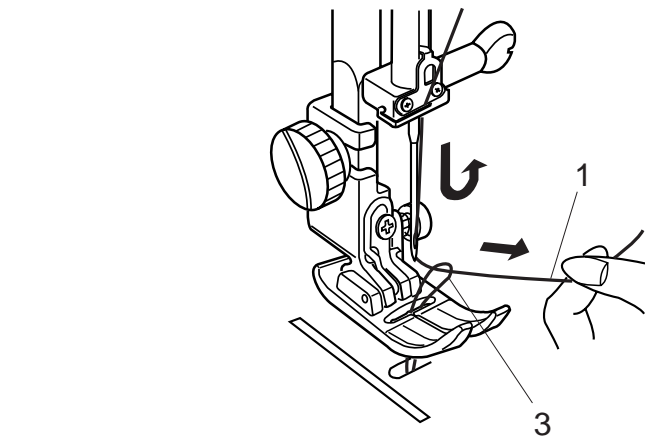

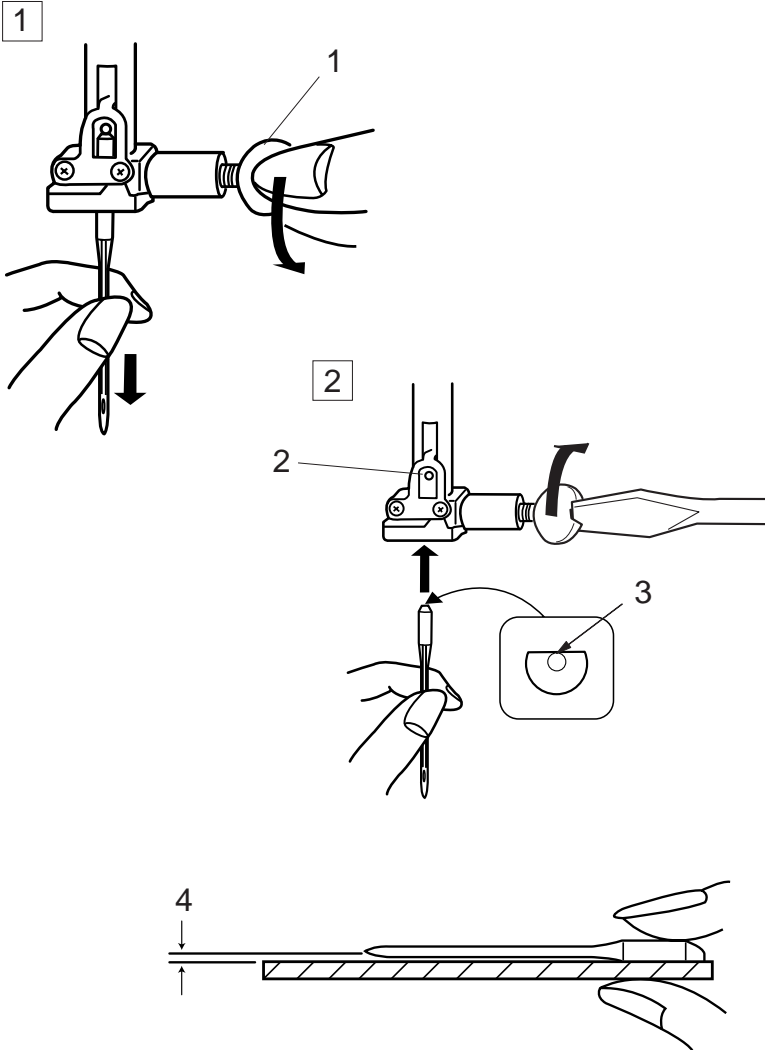

Changing Needles

Raise the needle by pressing the Up/Down Needle button and lower the presser foot.
Turn off the power switch.

- Loosen the Needle Clamp Screw by turning it counterclockwise.
Remove the Needle from the clamp.

1 Needle Clamp Screw

- Insert a new Needle into the Needle Clamp with the Flat Side of the needle to the rear.
When inserting the Needle into the Needle Clamp, push it up against the stopper pin and tighten the Needle Clamp Screw firmly.

2 Stopper Pin
3 Flat Side

To check needle straightness, place the flat side of the needle onto something flat (a needle plate, glass etc.)
The gap between the needle and the flat surface should be consistent.
Never use a blunt needle.

4 Gap

CAUTION:

Always make sure to turn the power switch off and disconnect the machine from power supply before changing the needle.

WEIGHT	FABRIC	TYPE of NEEDLE	NEEDLE SIZE
Very Light	Chiffon, Georgette, Fine Lace, Organdy Net, Tulle	Universal Ball Point	9 (65) 9 (65)
Light	Batiste, Voile, Lawn, Pure Silk, Crepe de Chine, Sheer Crepe, Chambray, Handkerchief Linen, Gingham, Challis, Percale, Wool Crepe, Peau de Soie, Taffeta, Satin, Silk Surah, Satin-backed Crepe, Qiana	Blue Tipped Needle Universal	11 (75) 11 (75) 12 (80)
	Single Knits, Jersey, Swim wear, and Tricot	Blue Tipped Needle Ball Point	11 (75) 11 (75)
	Leather Suede	Wedge Point Leather Needle	11 (75)
Medium	Flannel, Velour, Velvet, Muslin, Velveteen, Poplin, Corduroy, Broadcloth, Linen, Chintz, Gabardine, Felt, Terry, Burlap, Quilted Fabrics	Universal	14 (90)
	Double Knits, (synthetic and natural) Stretch Velour, Stretch Terry, Sweater Knits	Ball Point	14 (90)
	Leather, Vinyl, Suede	Wedge Point Leather Needle	14 (90)
Heavy	Denim, Sailcloth, Ticking	Denim Needle	16 (100)
	Double Faced Wool, Heavy Coating, Fake Fur, Drapery Fabrics	Universal	16 (100)
	Leather, Suede	Wedge Point Leather Needle	16 (100) 18 (110)
Very Heavy	Canvas, Duck, Upholstery Fabrics	Universal	16 (100)
	Topstitching for Special Finish	Topstitching Needle	14 (90)

Balancing Thread Tension

Auto tension

This machine features an **Auto** setting in the tension control, which covers a wide range of sewing condition. Set the tension control dial at **Auto** for general sewing, unless specifically indicated in this manual.

1 Setting Mark

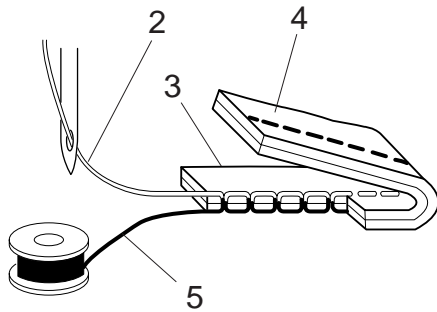
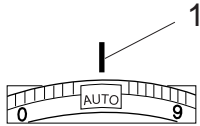

Correct tension:

The ideal straight stitch has threads locked between two layers of fabric
For an ideal zigzag stitch, the bobbin thread does not show on the right side of the fabric, and the needle thread shows slightly on the wrong side of the fabric.

- 2 Needle Thread
- 3 Right Side of the Fabric
- 4 Wrong Side of the Fabric
- 5 Bobbin Thread

Manual tension adjustment

Manual tension adjustment may be needed depending on the sewing materials, layers of fabric and other sewing conditions.

Needle thread tension is too tight:

If the bobbin thread appears on the right side of the fabric.
Loosen the needle thread tension by moving the dial to a lower number.

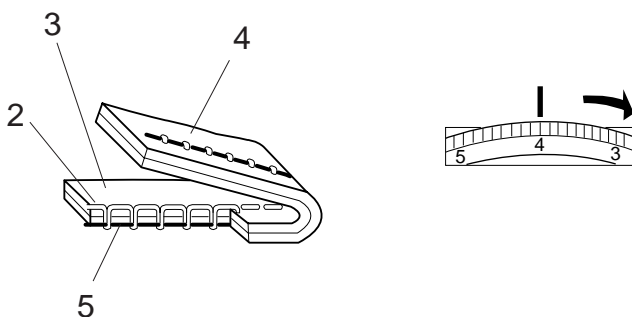
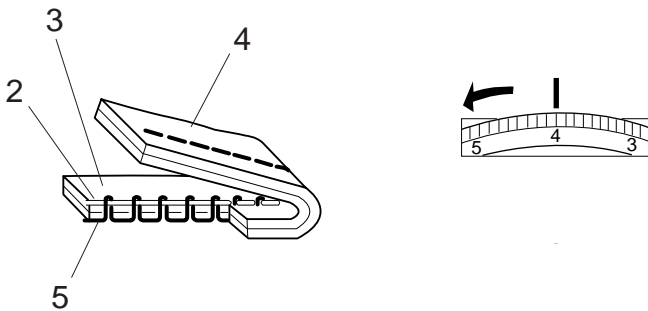

Needle thread tension is too loose:

If the needle thread appears on the wrong side of the fabric.
Tighten the needle thread tension by moving the dial to a higher number.

Adjusting the Foot Pressure

The foot pressure control dial should be set at “3” for regular sewing.

Reduce the pressure to “2” for applique, cut work, drawn work and basting.

Set the dial at “1” when sewing extra fine fabrics.

Foot pressure control dial

- 1 Setting mark

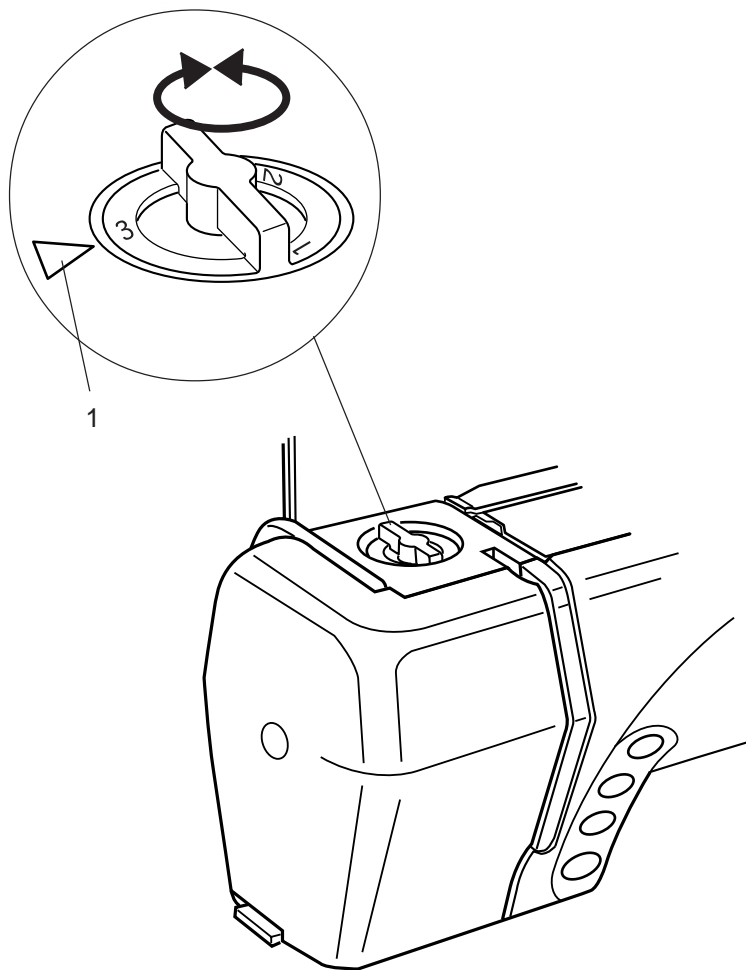

Dropping the Feed Dog

The feed dog will automatically drop when the basting stitch, button sewing or the embroidery mode has been selected.

The feed dog can also be lowered by the drop feed lever for sewing on buttons, manual embroidery. Push the drop feed lever to the left to lower the feed dog.

Push the lever to the right to raise the feed dog, it will return to the up position when starting the machine.

- 1 Drop Feed Lever
- 2 Down position
- 3 Up position

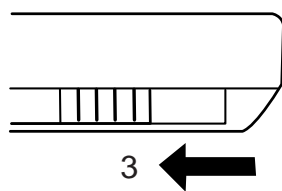
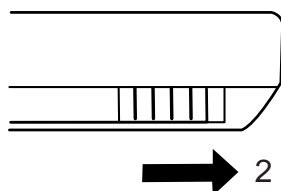
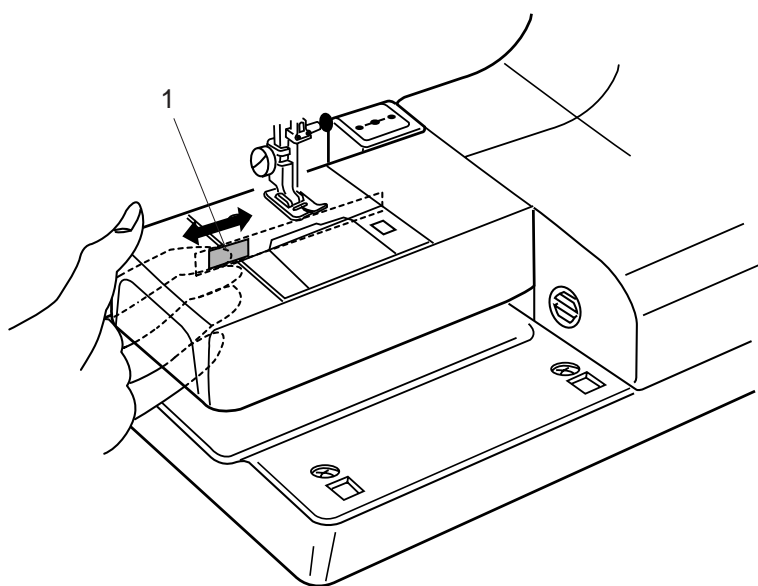

NOTES:

The feed dog should be in the up position for normal sewing. Turn the handwheel toward you to check if the feed dog comes up after setting the lever in the up position.

The feed dog will automatically drop when the the embroidery mode, basting stitch, button sewing. has been selected.

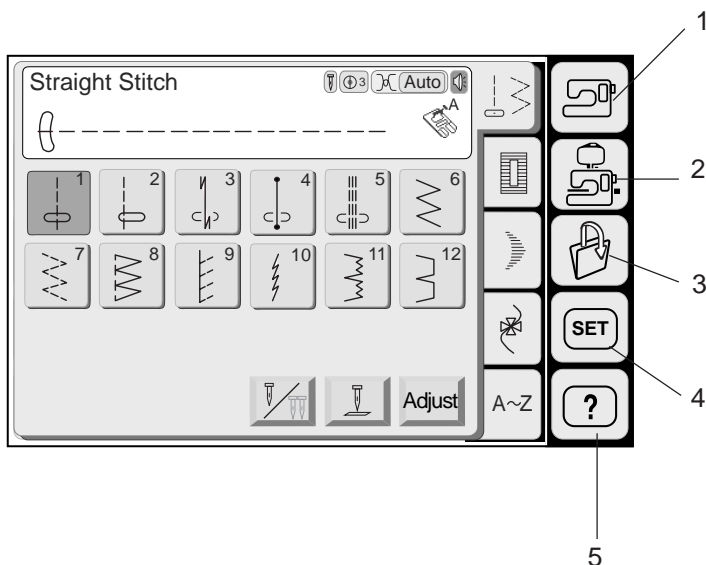

Mode Selection

When you turn on the power switch, the Visual Touch Screen will show the opening “Welcome” window, then the Ordinary Sewing Mode will appear after a few seconds.

The machine will be set for the straight stitch sewing.

NOTE;

After turning on the power, it takes approximately six seconds for the pattern selection window to be displayed on the visual touch screen. (This is the required boot up time and is not a defect)

Mode selection keys

1 Ordinary sewing mode key (See page 26.)

Press this key to enter the Ordinary Sewing Mode.

2 Embroidery mode key (See page 79.)

Press this key to enter the Embroidery Mode.

3 File open key (See page 99.)

Press this key to open files such as programmed stitch patterns or embroidery designs you have saved.

4 Mode setting key (See page 22.)

Press this key to enter the My Setting Mode. In this mode, you can change the machine settings to your preference. The machine settings for Ordinary Sewing, Embroidery, Language Selection and Common Settings are available in this mode.

5 Quick help mode key (See page 100.)

Press this key for helpful tips and general information on machine’s function.

CAUTION:

Do not press the surface of the Visual Touch Screen with hard or sharp objects like pencils, screwdrivers or the like.

NOTES:

When you select a pattern or function on the screen, it is not necessary to press hard; just touch the keys with your fingertip.

Use a dry soft cloth to wipe the screen.

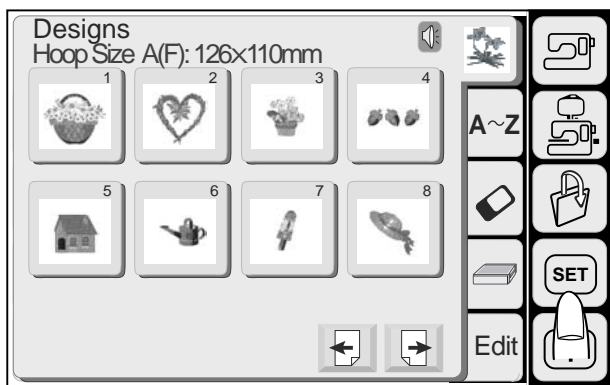

SETTING MODE

Pressing the SET key will open the mode setting window.

1 SET key

Press the SET key to customize the machine settings.

2 Flag key (Language selection key)

Press the flag key to select the language for the screen display. You can select one of 11 languages.

3 Screen contrast

The visual touch screen contrast can be adjusted. Press the Plus (+) key, to sharpen the screen contrast. Press the Minus (-) key, to fade the screen contrast.

4 Sound control

The buzzer volume can be adjusted. The volume level can be set from (0 to 10) and the default setting is 5. Press the Plus (+) key, to increase the buzzer volume. Press the Minus (-) key, to decrease the buzzer volume.

When you select 0 the buzzer turns off.

5 Eco mode

After turning on the power switch, if you have not used the machine, after a while, the machine will enter Eco Mode. The visual touch screen will go dark and the sewing light will turn off.

Whenever you touch the screen while the machine is in Eco mode, the screen and sewing light will turn on again.

You can set the Eco mode timer from 1 minute to 30 minutes. The default setting is 10 minutes.

To set the Eco Mode timer:

Press the Plus (+) key to increase the timer setting. Press the Minus (-) key to decrease the timer setting.

To turn off the Eco mode, Press the Plus (+) key until "OFF" shows in the box.

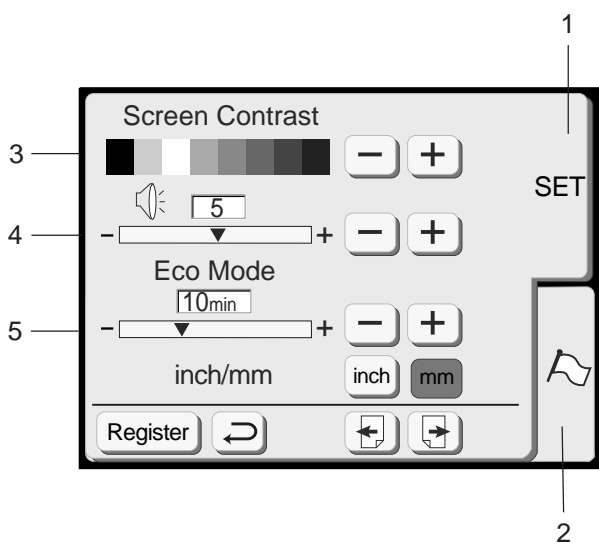

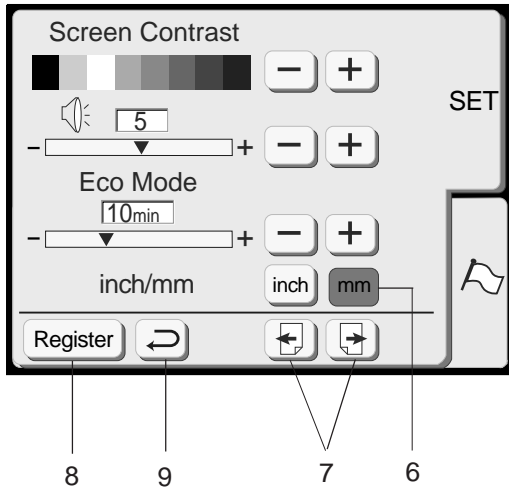

6 Inch/Millimeter

You can set your machine's measuring unit to either inch or millimeter depending upon your preference.

The default unit setting is millimeter.

Press the "inch" or "mm" key to select the unit you preferred.

NOTE:

Stitch length and width are displayed in millimeter regardless of the inch/mm setting.

7 Page keys

You can turn the pages by pressing the page keys.

Press the page forward key to view the next page.

Press the page back key to view the previous page.

8 Register key

Press this key to register the settings and return to the previous screen.

9 Return key

Press this key to return to the previous screen without registering the settings.

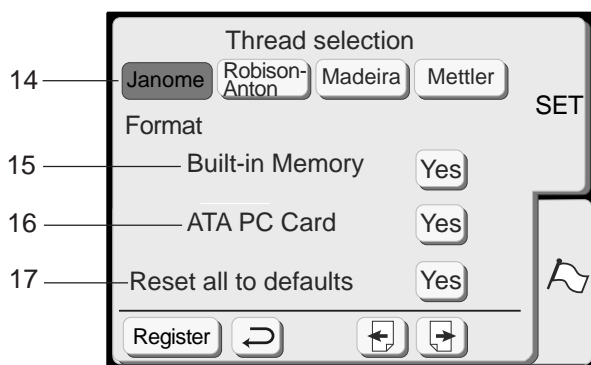
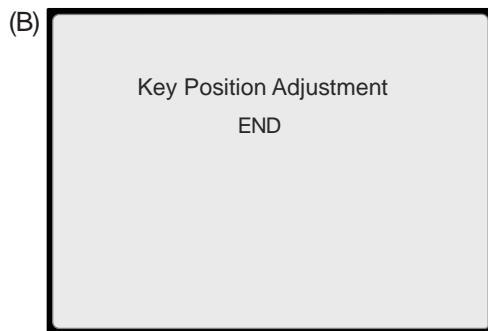
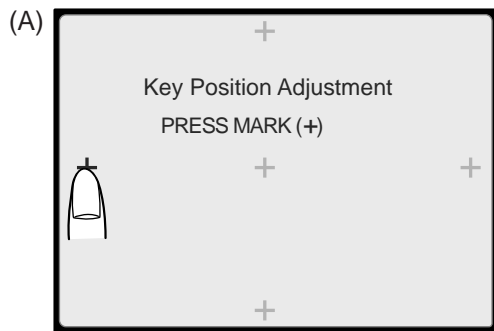
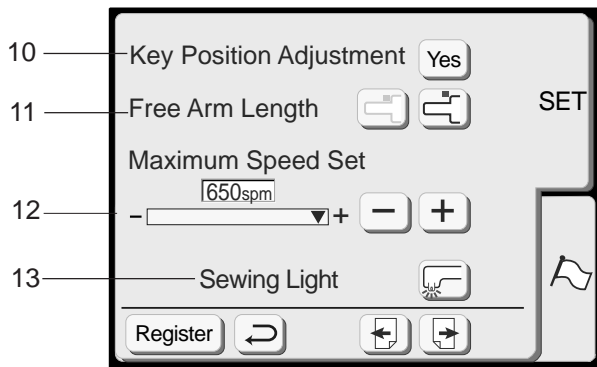

10 Key position adjustment

If you think the touch panel keys are out of alignment, you can calibrate them in the key position adjustment window.

When you press the Yes key, window (A) will be shown. With your finger, press the crosses as they appear in order. When you press the last crosses, the window (B) will be shown.

11 Free arm length

The carriage will move allowing you to use the full length of the free arm, when you press the key. Press the key to return the carriage to its home position.

12 Embroidery maximum speed:

The maximum sewing speed can be changed from 400 to 650 spm for embroidery sewing. The default setting is 650 spm (stitch per minute).

Press the Minus key to reduce the maximum sewing speed. Press the Plus key to increase the maximum sewing speed.

NOTE:

Reduce the sewing speed when sewing patterns with narrow zigzag stitches that tend to distort at high speed.

13 Sewing light

You can turn the sewing light on or off by pressing the sewing light key.

14 Thread selection

There are four brands of embroidery thread to choose from. Press the key of the thread you wish to use. The color code of the selected brand will be shown on the color/part key along with the name of the color.

Formatting the memory

If the internal memory or ATA PC card does not function due to damage to the memory bank, you need to re-enable it by formatting the memory.

15 To format the internal memory, press the Yes key next to Built-in memory.

16 To format the ATA PC card or Compact Flash, press the Yes key next to ATA PC card.

NOTE:

Formatting will erase all data stored in the memory.

17 Reset all to default

Pressing the Yes key will return all settings except for language to defaults (the same settings as when you purchased the machine).

Language Selection

You can select one of the following 11 languages by pressing the corresponding key.

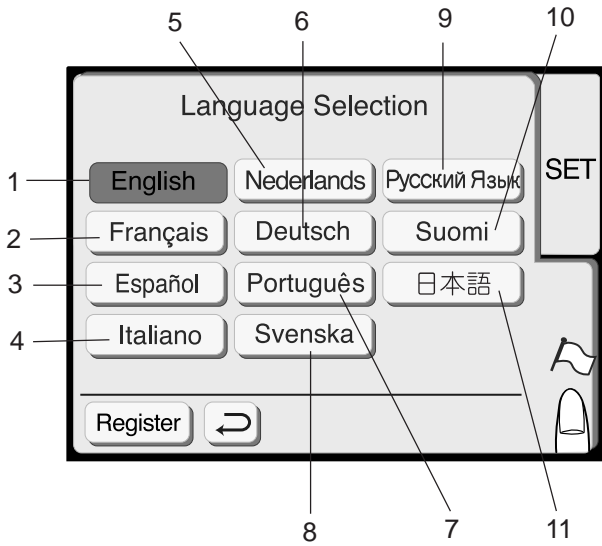

- 1 English
- 2 French
- 3 Spanish
- 4 Italian
- 5 Dutch
- 6 German
- 7 Portuguese
- 8 Swedish
- 9 Russian
- 10 Finnish
- 11 Japanese

ORDINARY SEWING

Pattern Selection

Press the Stitch Pattern Key to select the desired pattern.

The Name of the Stitch, Stitch Image of the selected pattern, the recommended foot and machine settings will appear on the screen.

Use the recommended foot and machine settings unless otherwise stated in this manual.

- 1 Name of Stitch
- 2 Stitch Image
- 3 Single/Twin Needle Indication
- 4 Recommended Foot Pressure
- 5 Recommended Tension Setting
- 6 Beep On/Off
- 7 Suitable Presser Foot

In the Ordinary Sewing Mode, the following 5 sewing choices are available.

(1) Utility Stitch Key:

Press this key to open the Utility Stitch window. The 12 most popular utility stitches are available in this window.

(2) Buttonhole Stitch Key:

This key opens the window for 7 Buttonhole variations, Button Sewing Stitch, Darning and Eyelet.

(3) Satin Stitch Key:

This key opens the window for Satin Stitches. The stitch combination can be stored in the memory bank.

(4) Decorative Stitch Key:

This key opens the multi-page window for Decorative Stitches. Stitch combinations can be saved in the memory bank.

(5) Monogramming Key:

This key opens the window for Monogramming. You can create monograms or a combination of letters and symbols.

(6) Adjust Key

When you press this key, the screen shows the manual setting window.

(7) Needle up/down key

You can set the needle position with this key, up or down when the machine stops.

(8) Twin needle key

Press this key when you wish to sew with a twin needle. The key will be grayed out if the selected stitch is not suitable for twin needle sewing.

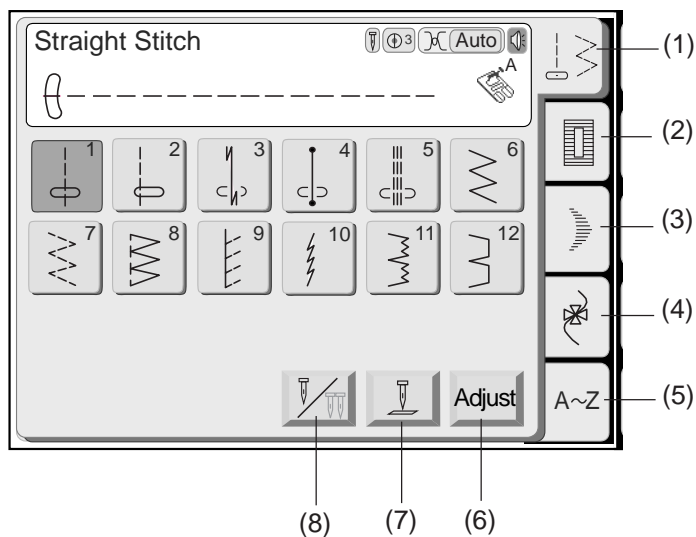
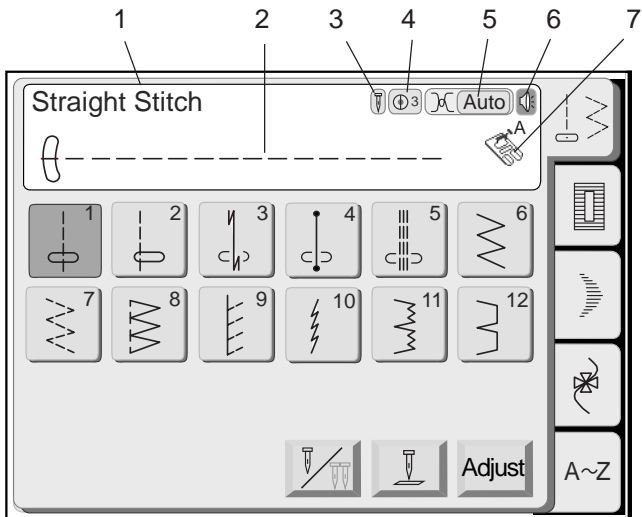

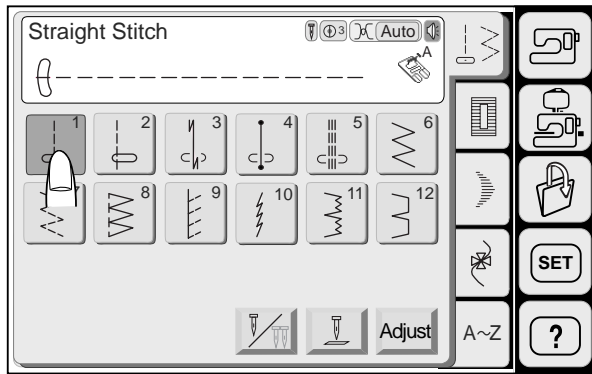

Utility Stitches

Straight stitch

Press Pattern 1 on the Visual Touch Screen.

To sew:

Raise the Presser Foot and position the fabric next to a seam guideline on the needle plate. Lower the needle to the point where you want to start.

Pull the needle and bobbin threads towards the rear.

Press the Start/Stop Button or Foot Control. Gently guide the fabric along the seam guideline letting the fabric feed naturally.

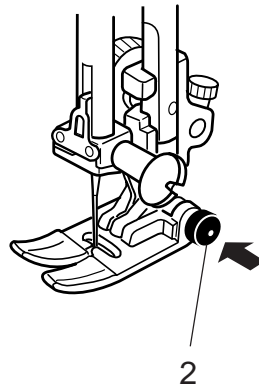
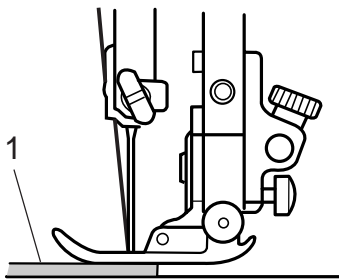
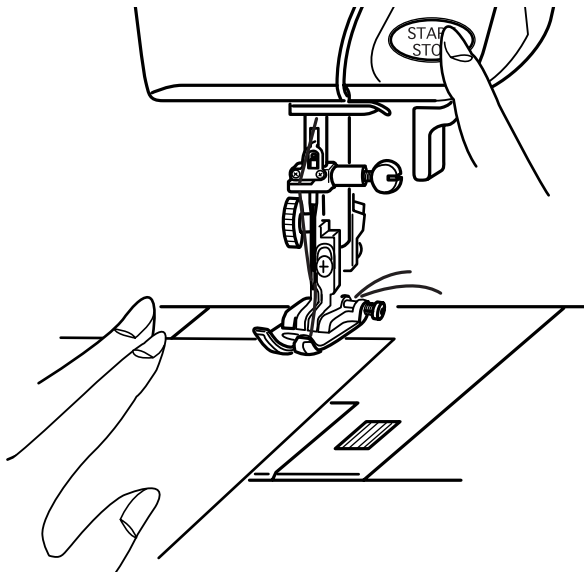

To sew from the edge of thick fabric:

The Black Button on the zigzag foot locks the foot in the horizontal position.

This is helpful when starting sewing from extreme edge of thick fabrics or sewing across a hem. Lower the needle into the fabric at the point where you wish to start sewing.

Lower the foot while pushing in the black button. The foot will be locked in the horizontal position to avoid slipping.

- 1 Thick fabrics
- 2 Black Button

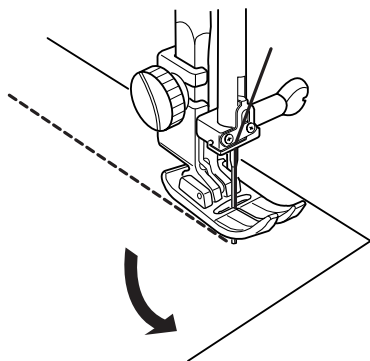

Changing sewing direction:

Stop the machine and bring the needle down into the fabrics by pressing the needle Up/Down button.

Raise the presser foot.

Pivot the fabric around the needle to change the sewing direction as desired.

Lower the presser foot and start sewing in a new direction.

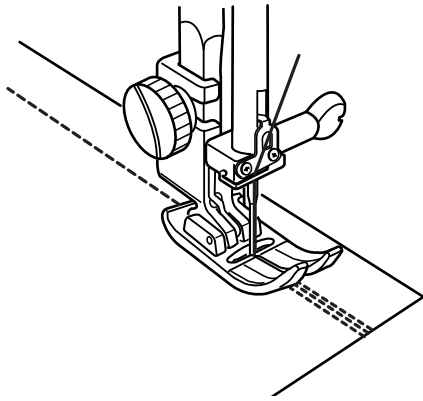

Securing seam

For fastening the ends of seams, press the Reverse Button and sew several reverse stitches. The machine sews in reverse as long as you press and hold the Reverse Button. Press the Reverse Button once when sewing the Lock-a-Matic stitch (pattern 3) or Locking stitch (pattern 4) so the machine will lock the stitch off and stop automatically.

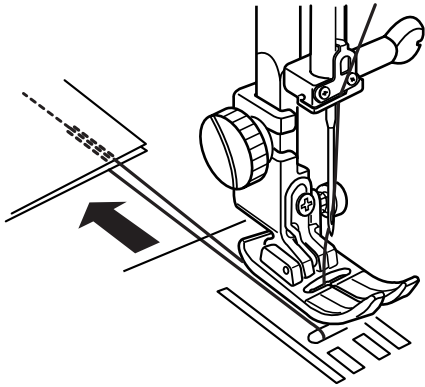

After finishing sewing, raise the presser foot and pull the fabric to the rear.

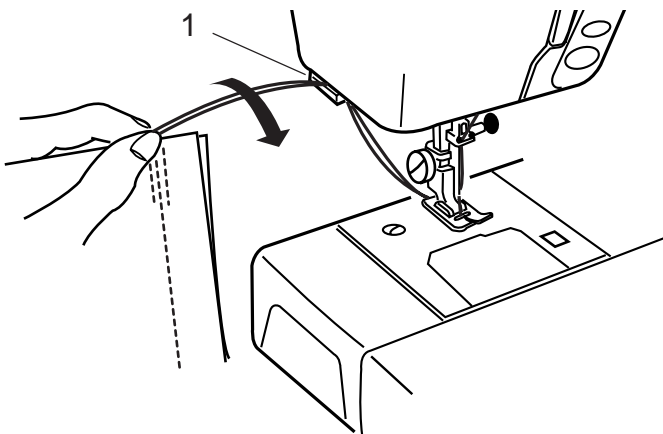

Draw both needle and bobbin threads up and into the Thread Cutter. The threads will be cut at the proper length for starting the next seam.

1 Thread Cutter

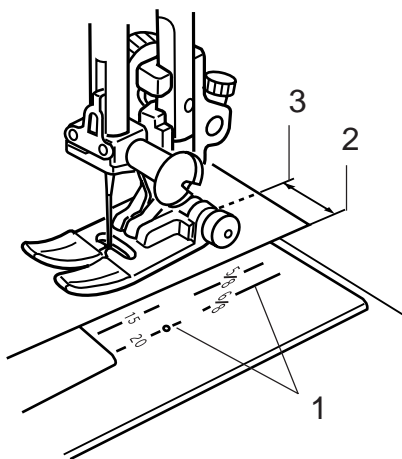

Using the seam guide lines

The seam guides on the needle plate and hook cover help you to measure seam allowances.

NOTE:

The number indicates the distance from the center needle position.

- 1 Guide Lines
- 2 Edge of the Fabric
- 3 Center Needle Position

Number	15	20	4/8	5/8	6/8
Distance (cm)	1.5	2.0	—	—	—
Distance (inch)	—	—	4/8	5/8	6/8

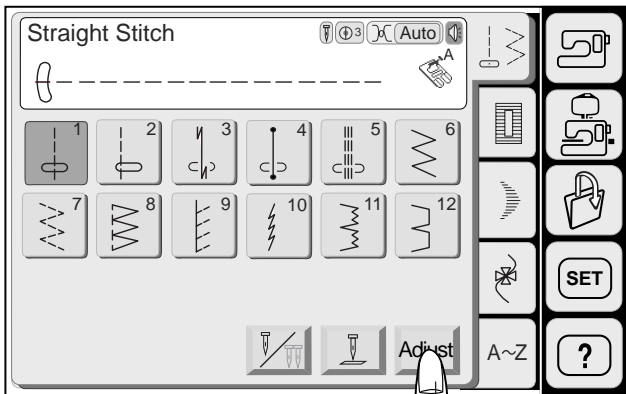

(1)

Adjusting the needle drop position and stitch length

When you press the Adjust key, the screen shows the manual setting window.

Press the **+** or **-** key to change the needle drop position or stitch length.

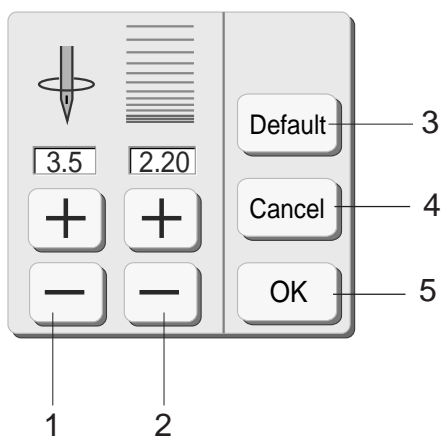

- 1 Needle Drop Position Adjusting Keys
- 2 Stitch Length Adjusting Keys
- 3 Default Key: Resumes the default settings.
- 4 Cancel Key: Cancels the last changes to setting.
- 5 OK Key: Enables the current setting.

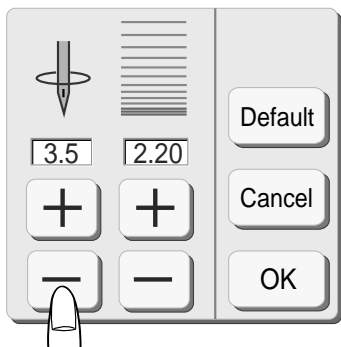

Changing needle drop position

When you press the **+** key, the needle moves to the right.

When you press the **-** key, the needle moves to the left.

0.0

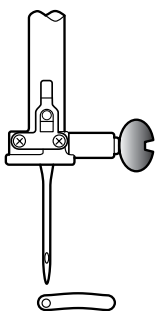

3.5

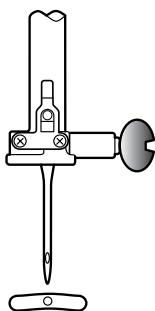

7.0

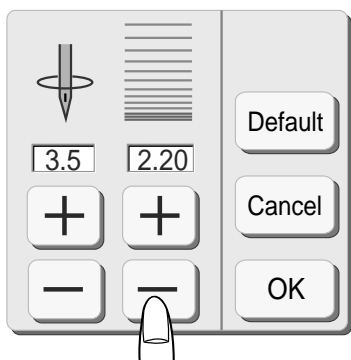
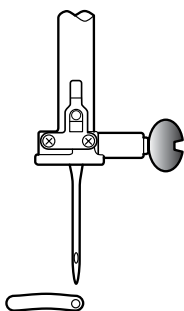

Changing stitch length

Press the **-** key to decrease the stitch length.

Press the **+** key to increase the stitch length.

1.0

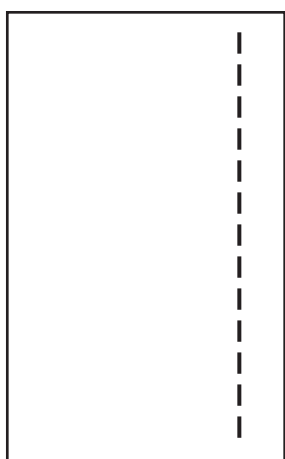

5.0

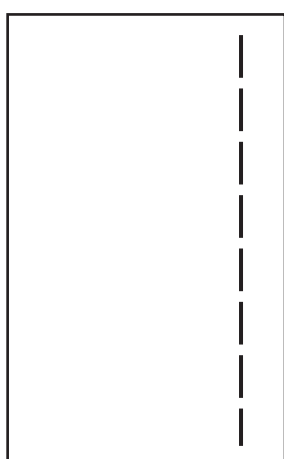

Variety of straight stitches

02



02 Straight Stitch in Left Needle Position

Use this stitch to seam the edge of the fabrics.

03

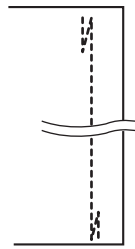
03 Lock-a-Matic Stitch

Use this stitch to secure the beginning and the end of a seam with backstitching.

When you reach the end of the seam, press the Reverse Button once.

The machine will sew four reverse stitches, four forward stitches, and then stop sewing automatically.

04

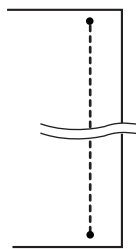
04 Locking Stitch

This unique stitch is used where an invisible locking stitch is needed.

Lower the needle close to the front edge of the fabric. The machine will sew several locking stitches in place and continue sewing forward.

When you press the Reverse Button at the end of the seam, the machine will sew several locking stitches in place, then stop sewing automatically.

05

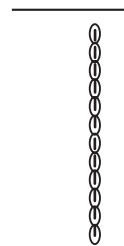
05 Triple Stretch Stitch

This strong, durable stitch is recommended for areas where both elasticity and strength are needed to ensure comfort and durability.

Use it to reinforce areas such as crotch and armhole seams.

Also use it when constructing items such as backpacks for extra strength.

10

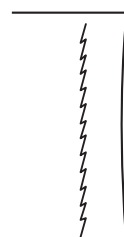

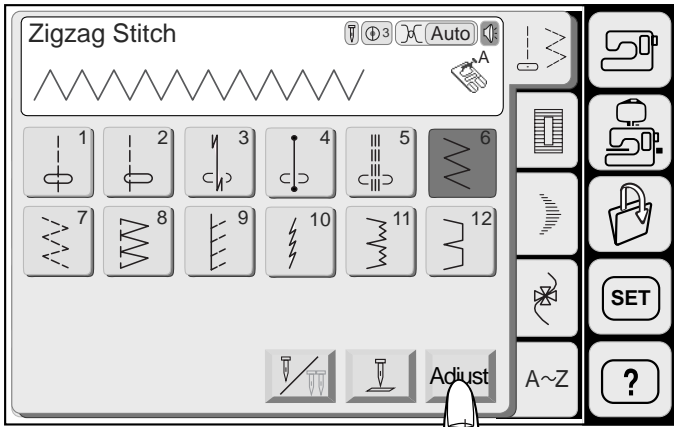

10 Stretch Stitch

This is a narrow stretch stitch designed to eliminate puckering on knit fabrics and bias seams, while permitting the seam to be pressed completely open flat.

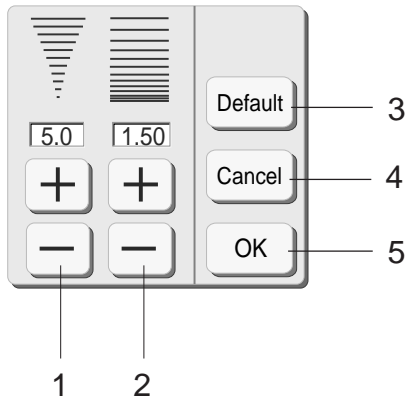

(1)



Zigzag stitch

This stitch is used for various sewing needs including overcasting. It can be used on most woven fabrics. It is the fastest way to finish an edge, leaving it neat and flat.

A dense zigzag stitch can also be used for applique.

Adjusting the stitch width and length

When you press the Adjust key, the screen shows Stitch Width and Stitch Length Plus **+** and Minus **-** keys.

(1) When you press the Adjust key, the screen shows the manual setting window.

Press the **+** or **-** key to change the stitch width or stitch length.

- 1 Stitch Width Adjusting Keys
- 2 Stitch Length Adjusting Keys
- 3 Default Key: Resumes the default settings.
- 4 Cancel Key: Cancels the last changes to setting.
- 5 OK Key: Enables the current setting.

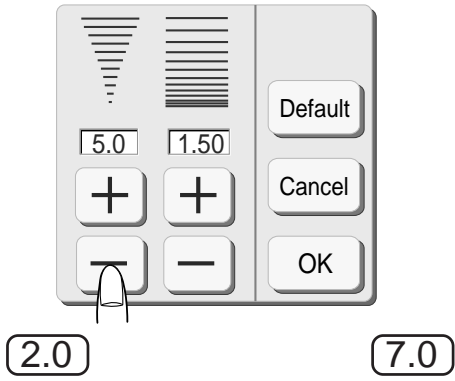

Changing stitch width

Press the **-** key to decrease the Stitch Width.
 Press the **+** key to increase the Stitch Width.

1 Stitch Width

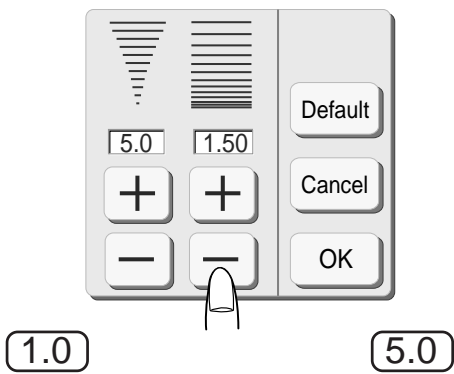
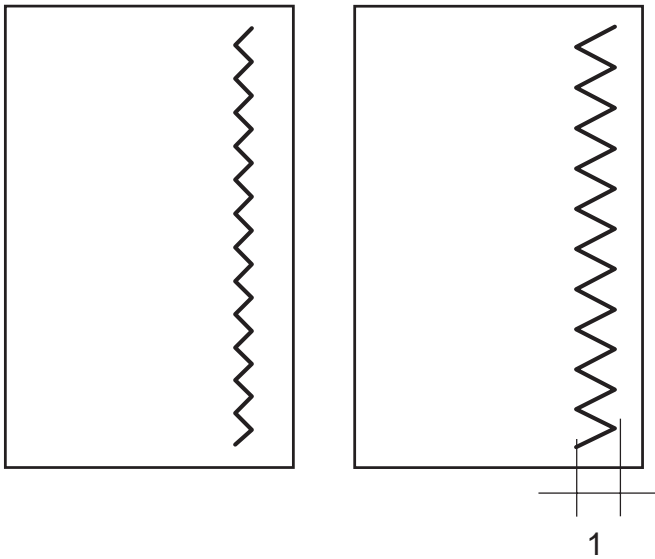

Changing stitch length

Press the **-** key to decrease the Stitch Length.
 Press the **+** key to increase the Stitch Length.

2 Stitch Length

After adjusting the settings press the OK key.

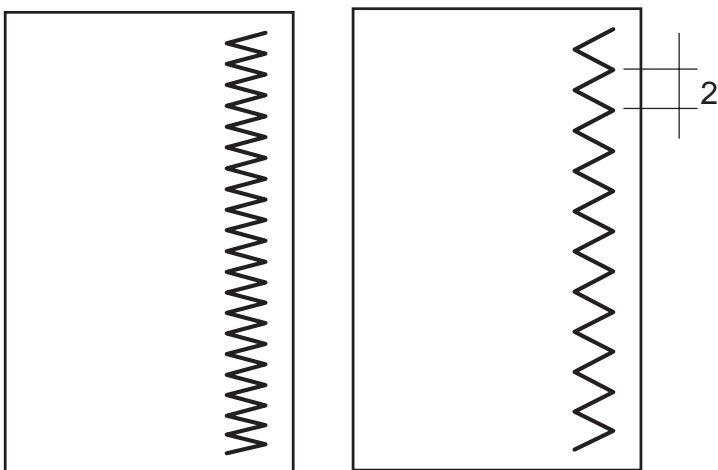

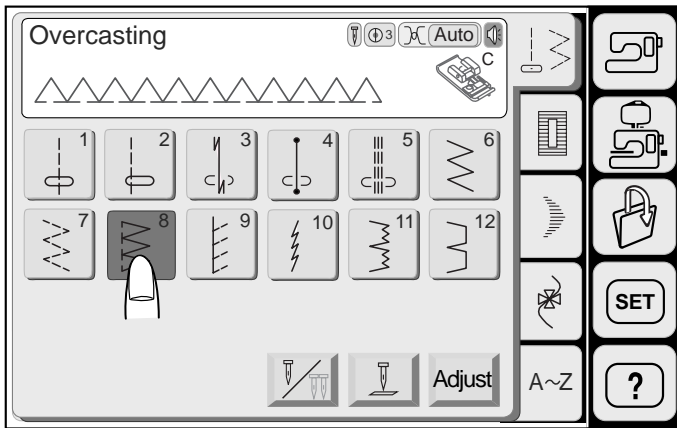

Overcasting with zigzag stitch

Select Pattern 8 and attach the Overedge Foot **C**.

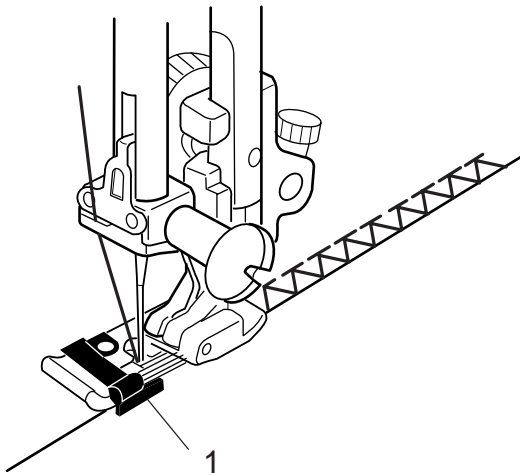

Place the fabric edge next to the Guide of the foot and then sew.

1 Guide

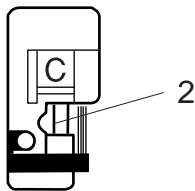

CAUTION:

When you use the Overedge Foot **C** or the Overcasting Foot **M**, you must set the zigzag width at 5.0 or wider to prevent the needle from hitting the Foot Wires.

2 Foot Wires

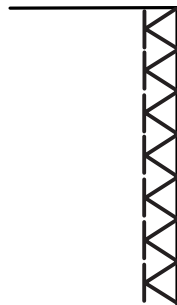

Variety of overcasting stitches

1
07

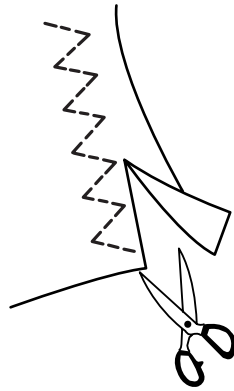
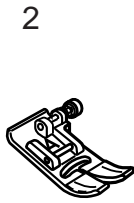
Multiple Zigzag Stitch (Tricot Stitch)

This stitch is used to finish a raw edge of synthetics and other stretch fabrics that tend to pucker.

Sew along the fabric edge leaving an adequate seam allowance. After sewing, trim off the seam allowance closer to the stitches.

- 1 Pattern 07
- 2 Zigzag foot A

1
09

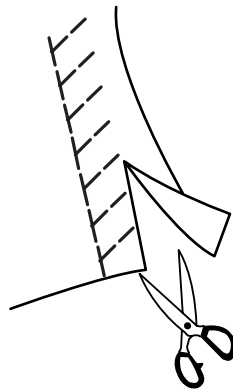
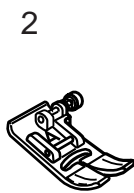
Knit Stitch

This stitch is recommended for sewing such fabrics as synthetic knits and stretch velour as it provides the greatest amount of elasticity and strength.

Sew along the fabric edge leaving an adequate seam allowance. After sewing, trim off the seam allowance closer to the stitches.

- 1 Pattern 09
- 2 Zigzag foot A

1
37

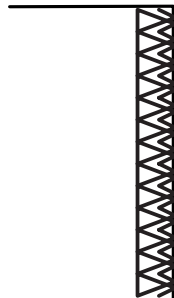
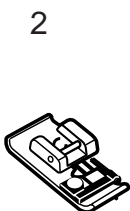
Double Overedge Stitch

This stitch is an excellent stitch for fabrics that tend to fray extensively such as linens and gabardines.

Two rows of zigzag stitches are simultaneously sewn over the edge to insure that the fabric will not ravel.

- 1 Pattern 37
- 2 Overedge Foot C

1
38

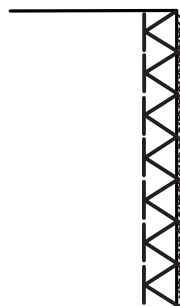
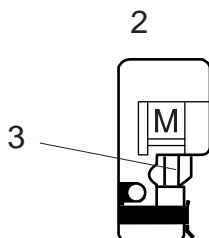
Overlock Stitch

This stitch finishes the edges of fabric similar to a commercial overlocking machine for a professional look.

- 1 Pattern 38
- 2 Overcasting Foot M

CAUTION:

When you use Overedge Foot **C** or Overcasting Foot **M**, you must set the zigzag width at 5.0 or wider to prevent the needle from hitting the Foot Wires.

- 3 Foot Wires

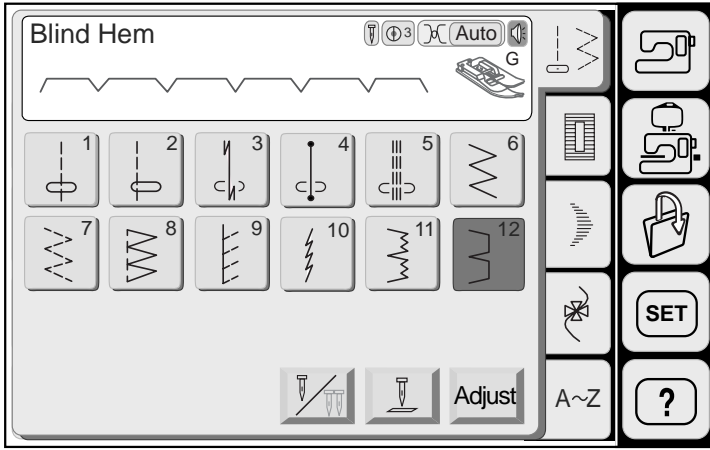

Blind hem stitch

Select the patterns 11 or 12.

NOTE:
Pattern 11 is for stretch fabrics.

Attach Blind Hem Foot G.
Fold the fabric to form a hem as shown.

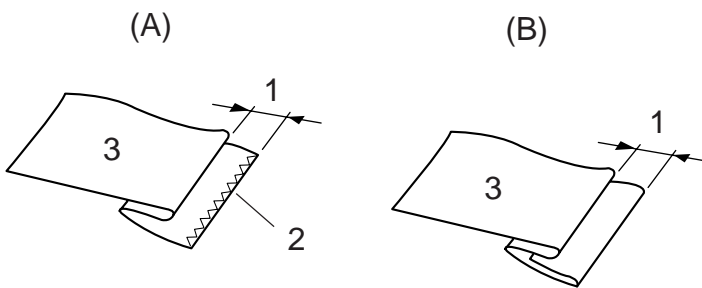

(A) Thick fabric
(B) Fine and medium weight fabric

- 1 0.4 - 0.7 cm (1/4")
- 2 Overcasting
- 3 Wrong Side of Fabric

Place the fabric so that the folded edge comes to the left side of the guide.

Lower the Presser Foot.

Adjust the needle drop position so that the needle just pierces the edge of the fold when the needle swings to the extreme left.

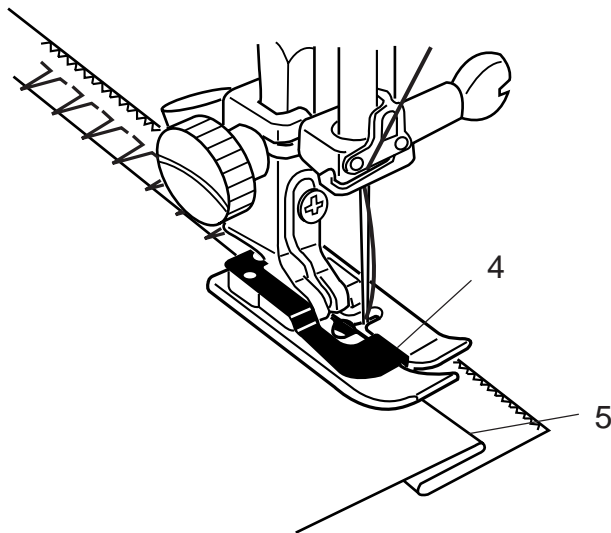

- 4 Guide
- 5 Folded Edge

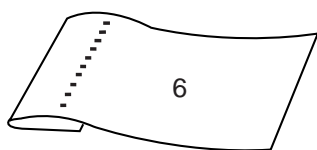

While sewing, guide the folded edge along the guide on the foot.

Open the fabric with the right side up.

- 6 Right Side of Fabric

Adjusting the needle drop position

Press the Adjust key to open the stitch width and length adjusting window.

Press the **-** key to move the needle position to the right.

Press the **+** key to move the needle position to the left.

Press the OK key to register the settings. The needle should just pierce the folded edge when it comes over to the left side.

- 1 Stitch Width Adjusting Keys
- 2 Default Key: Resumes the default settings.
- 3 Cancel Key: Cancels the last changes to settings.
- 4 OK Key: Enables the current setting.
- 5 Guide on the Foot
- 6 Left Needle Drop position
- 7 Right Needle Drop Position

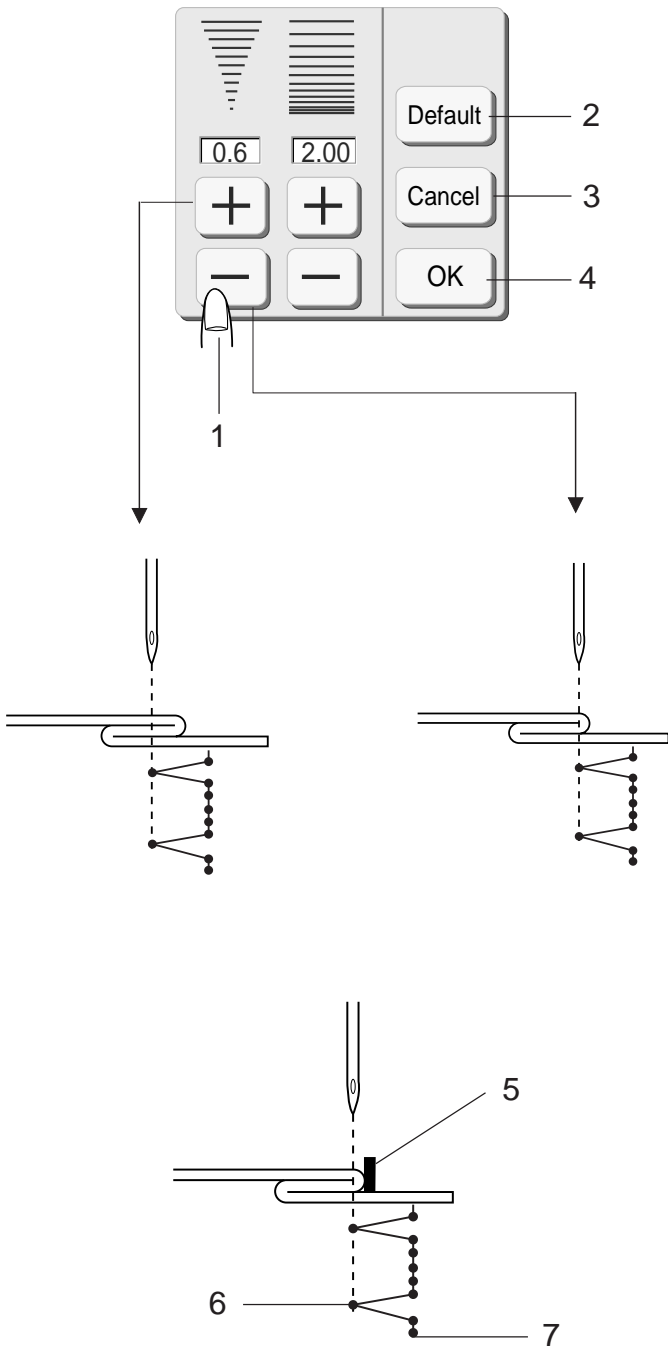

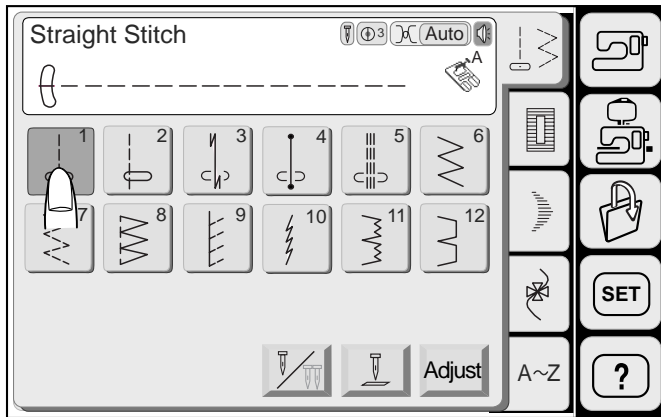

Zipper sewing

Select the pattern 01.
Attach the Zipper Foot **E**.

Attaching the zipper foot

- (A) Attach Zipper Foot **E** with the Pin on the Right-hand Side to the Groove to sew the left side of the zipper.
- (B) Attach Zipper Foot **E** with the Pin on the Left-hand Side to the Groove to sew the right side of the zipper.

- 1 Pin
- 2 Groove

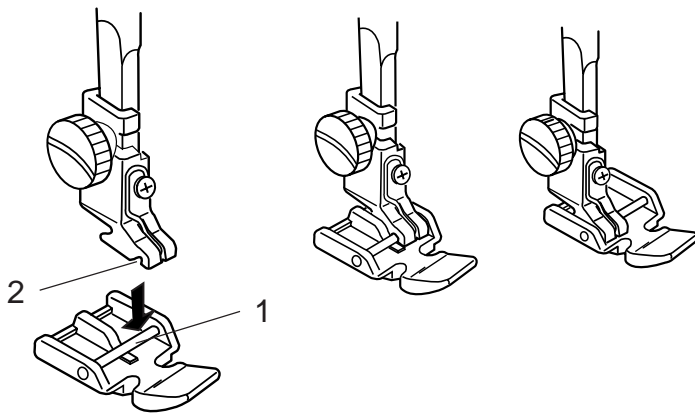

1 Fabric Preparation for Zipper Sewing

Add 1 cm (3/8") to the zipper size. This is the overall Opening Size.

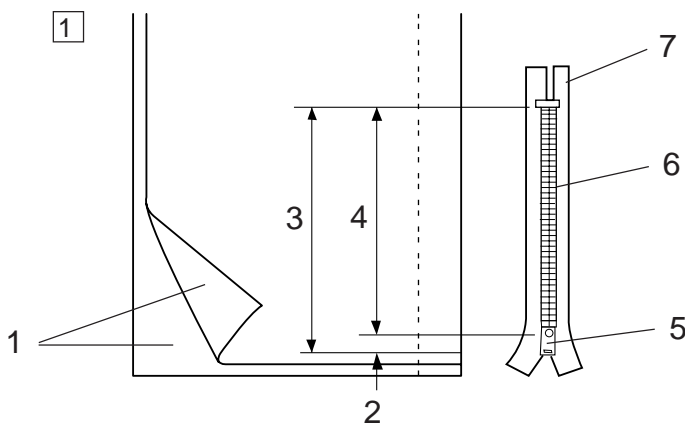

2 Place the right sides of the fabric together and sew to the End of the Zipper Opening. Fasten the seam with reverse stitching.

Press the Adjust key and manually increase the stitch length to 5 mm (3/16"). Press the OK key to register the setting and loosen the tension to "1". Sew the zipper opening. You may also use the Basting Stitch.

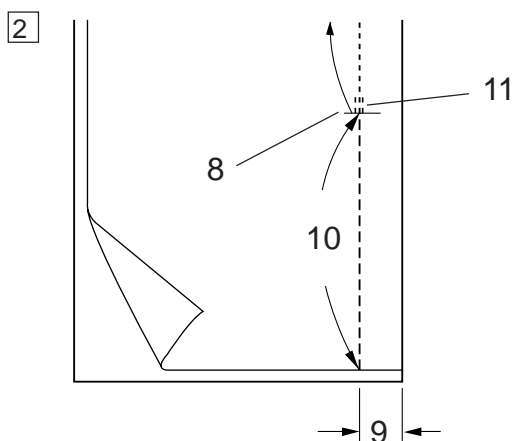

- 1 Right Side of the Fabric
- 2 1 cm (3/8")
- 3 Opening Size
- 4 Zipper Size
- 5 Slider
- 6 Zipper Teeth
- 7 Zipper Tape
- 8 End of the Opening
- 9 2 cm (13/16") Seam Allowance
- 10 Zipper Opening
- 11 Reverse Stitches

3

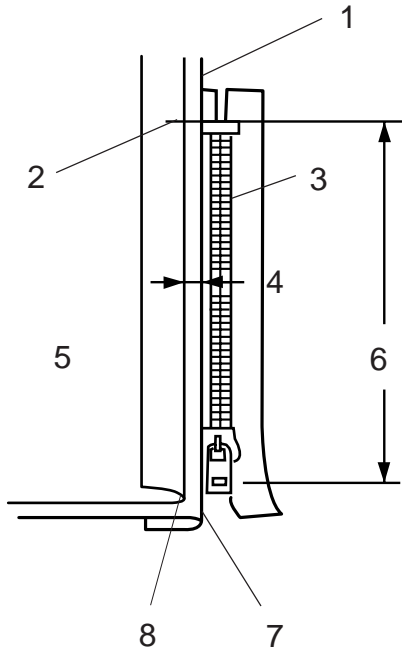

To Sew

3 Fold back the left seam allowance. Turn under the right seam allowance to form a 0.2 to 0.3 cm (1/8") Fold. Place the zipper teeth next to the fold and pin it in place.

- 1 Lower Fabric
- 2 End of the Zipper Opening
- 3 Zipper Teeth
- 4 0.2 to 0.3 cm (1/8")
- 5 Wrong Side of the Upper Fabric
- 6 Opening Size
- 7 Fold
- 8 Basting Line

4

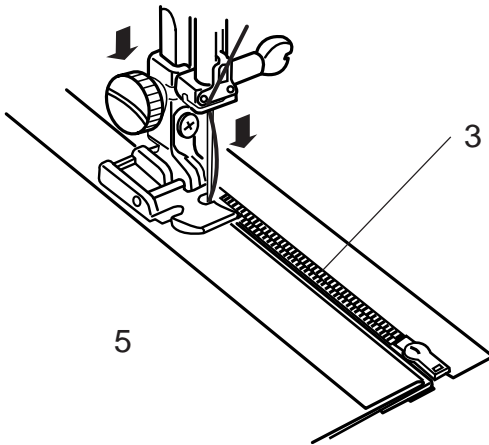

4 Set the stitch length back to "2.2" and thread tension to **AUTO**. Attach Zipper Foot **E** with the Pin on the Right-hand Side. Sew through the fold and zipper tape guiding the zipper teeth along the edge of the foot.

5

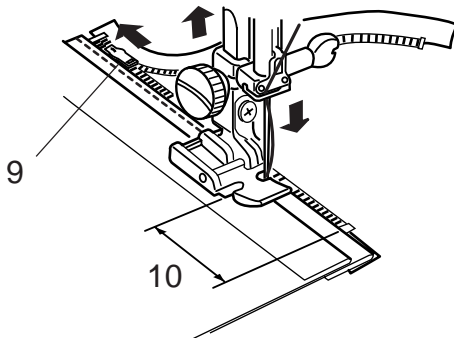

5 Stop just before the foot reaches the slider on the zipper tape. Lower the needle slightly into the fabric. Raise the foot and open the zipper. Lower the foot and stitch the remainder of the seam.

- 9 Slider
- 10 5 cm (2")

6

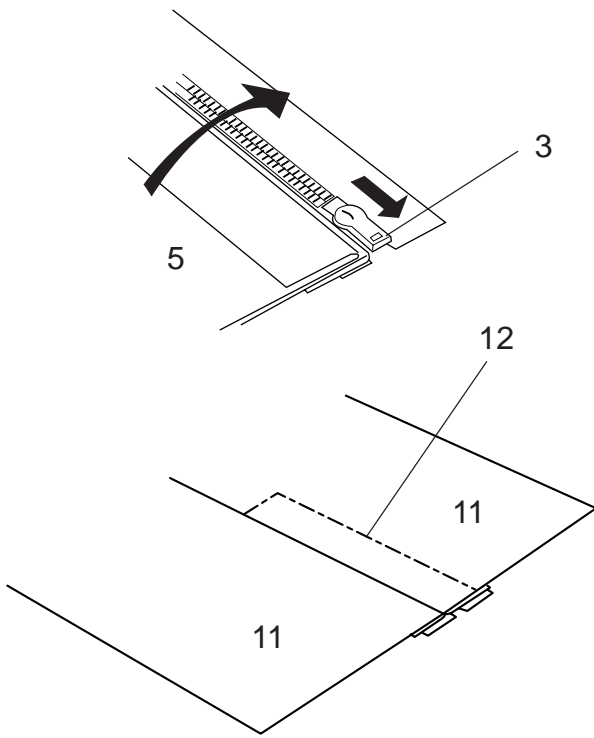

6 Close the zipper and spread the fabric open flat with the right side up.

Baste the upper fabric and zipper tape together.

11 Right Side of the Fabric
12 Basting

7

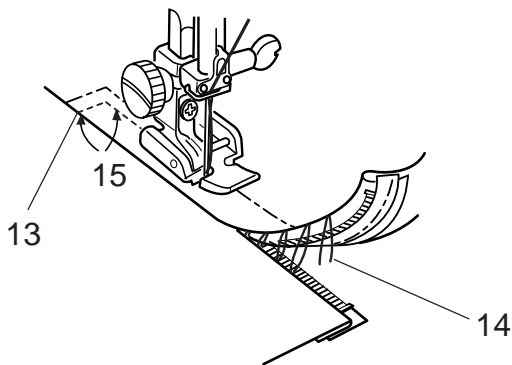

7 Reattach Zipper Foot **E** with the Left Pin. Stitch through the fabric and zipper tape. Stop about 5 cm (2") from the top of the zipper.

13 End of the Opening
14 Basting Stitches
15 0.7 to 1 cm (3/8")

8

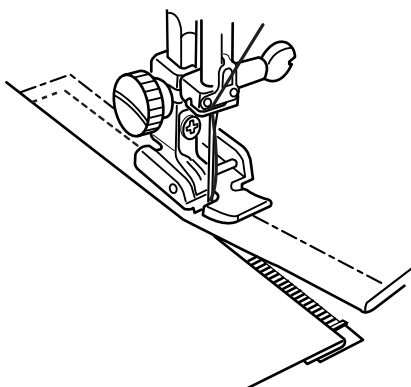

8 Lower the needle slightly into the fabric, raise the foot, remove the Basting Stitches and open the zipper then stitch the remainder of the seam.

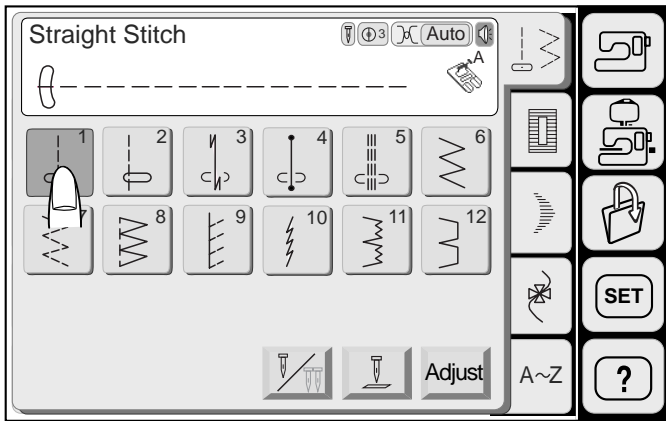

Quilting

Select the pattern 01.

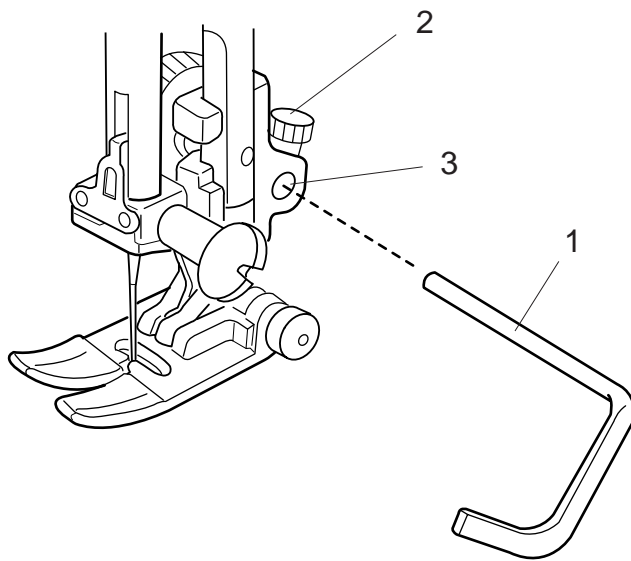

Regular quilting

Use this Quilting Bar with the Zigzag Foot. Loosen the Screw on the back of the Foot Holder and insert the Quilting Bar into the Hole of the Foot Holder. Set the Quilting Bar to the desired position, then retighten the screw.

- 1 Quilting Bar
- 2 Screw
- 3 Hole

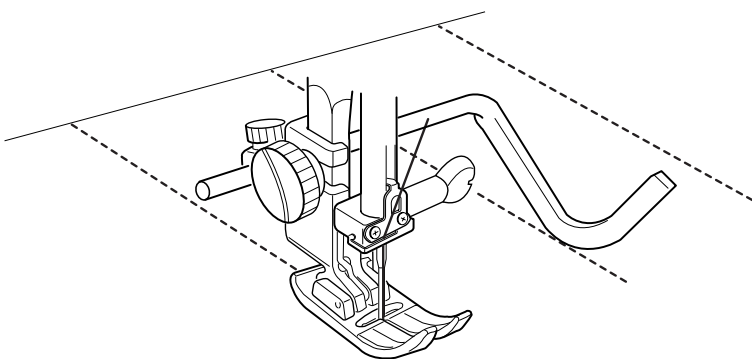

Variety of buttonholes and their uses

13



Sensor

13 Sensor (Square) Buttonhole

This square buttonhole is widely used on medium to heavy weight fabrics. The buttonhole size is automatically determined by placing a button in the foot.

14



Auto

14 Auto (Square) Buttonhole

This is also a square buttonhole similar to the Sensor Square Buttonhole, but you can manually set the buttonhole size and you memorize the size to sew buttonholes of the same size.

15



15 Round End Buttonhole

This buttonhole is used on fine to medium weight fabrics especially for blouses and children's clothes.

16



16 Keyhole Buttonhole

This buttonhole is rounded at both ends and is used on fine, delicate fabrics such as fine silk.

17



17 Rounded Keyhole Buttonhole

The Keyhole Buttonhole is widely used on medium to heavy weight fabrics. It is also suitable for larger and thicker buttons.

18



18 Stretch Buttonhole

This buttonhole can be used on stretch fabrics. It can be used as a decorative buttonhole.

19



19 Knit Buttonhole

This buttonhole is suitable for knit fabrics. It can also be used as a decorative buttonhole.

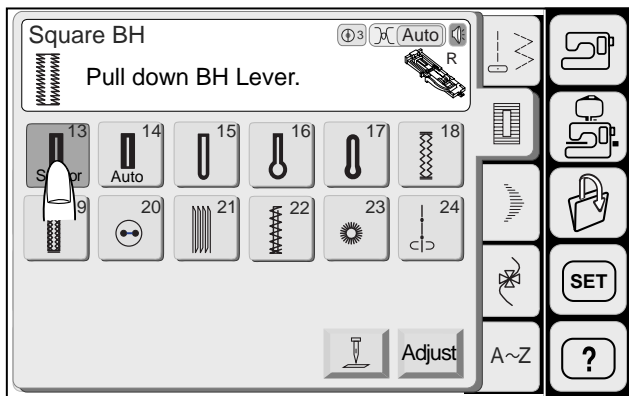

Sensor buttonhole

Select the pattern 17.

The buttonhole size is automatically set by placing a button into the button holder in the rear of the Automatic Buttonhole Foot R.

NOTE:

The button holder of the foot takes a button size of up to 2.5 cm (1") in diameter.

Attach the Automatic Buttonhole Foot R.

To sew

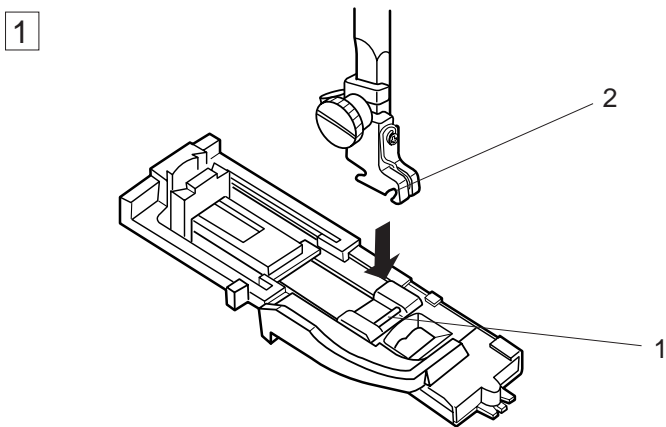

- 1 Press the Up/Down Needle button to raise the needle. Attach the Automatic Buttonhole Foot R snapping the Pin into the Groove of the foot holder. Raise the Presser Foot.

- 1 Pin
- 2 Groove

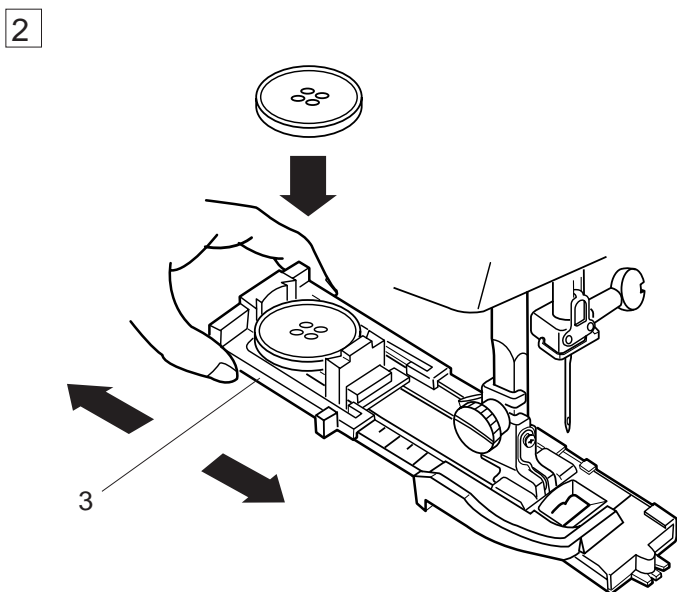

- 2 Pull the Button Holder to the rear, and place the button in it. Push it tightly against the button.

- 3 Button Holder

NOTE:

If the button is extremely thick, make a test buttonhole on an extra piece of the fabric. If it is difficult to fit the button through the test buttonhole, you can lengthen the buttonhole by pulling the Button Holder back a little. The length of the buttonhole will be increased.

3

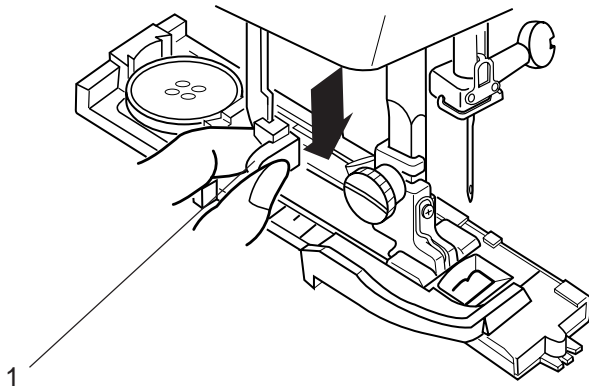

3 Pull the Buttonhole Lever down as far as it will go.

1 Buttonhole lever



Pull down BH Lever.



NOTE:

A warning message will appear and the machine will stop automatically if you start to sew a buttonhole without pulling down the buttonhole lever. Press the Return  key and pull down the buttonhole lever to restart.

4

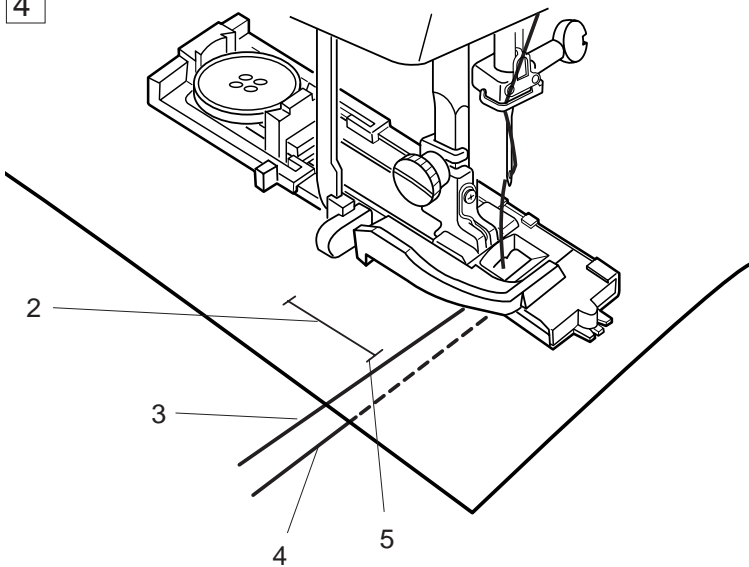

4 Insert the corner of the fabric under the foot. Press the Up/Down Needle button twice. Remove the fabric to the left to draw both threads under the foot. Place the garment under the foot, and lower the needle at the Starting Point of the Mark. Then lower the Automatic Buttonhole Foot **R**.

- 2 Buttonhole Mark
- 3 Needle Thread
- 4 Bobbin Thread
- 5 Starting Point

5

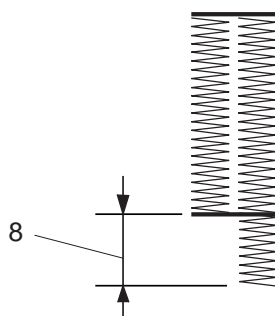
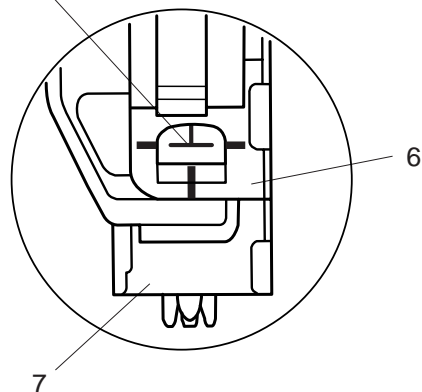

NOTE:

Make sure there is no gap between the Slider and Spring Holder, otherwise the left and right lengths will be different.

- 6 Slider
- 7 Spring Holder
- 8 Sewing Gap

5

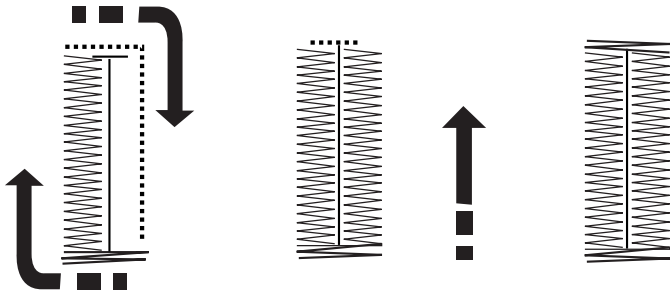

Completed
Raise Presser Foot.

5 Press the Start/Stop Button to sew the buttonhole.

The buttonhole will be automatically sewn in a single step.

The front bartack and left row first, then the right row and back bartack. The machine will stop automatically when the buttonhole is completed.

6

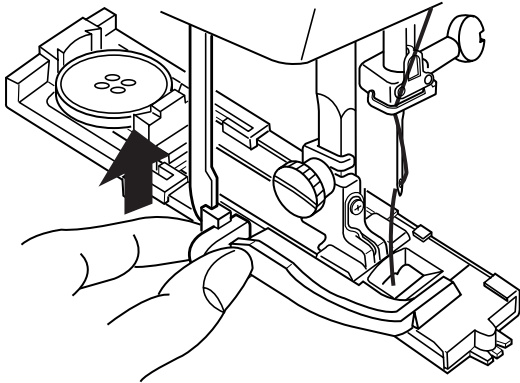

6 When buttonhole sewing is finished, push the buttonhole lever up as far as it will go.

7

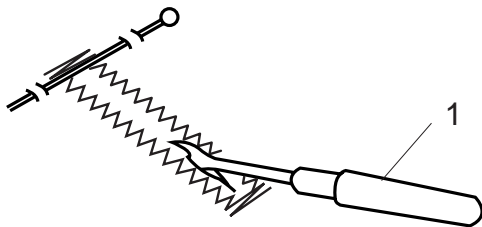

7 Remove the fabric and place a pin just below the bartack at each end to prevent accidentally cutting threads.

Cut the opening with the Seam Ripper. Use an Eyelet Puncher to open a keyhole buttonhole.

- 1 Seam Ripper
- 2 Eyelet Puncher

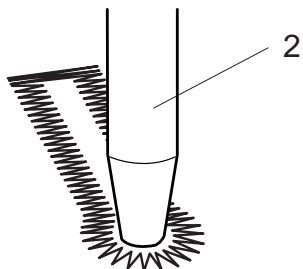

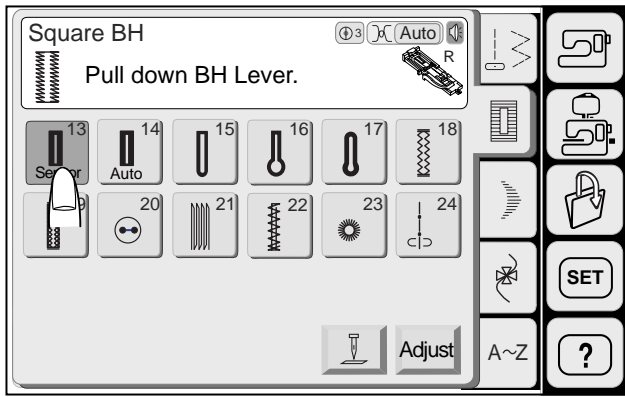

Corded buttonhole

To sew the corded buttonhole, follow the same procedure as for the Sensor Buttonhole; refer to the instructions on pages 43 to 45.

Select the pattern 13.

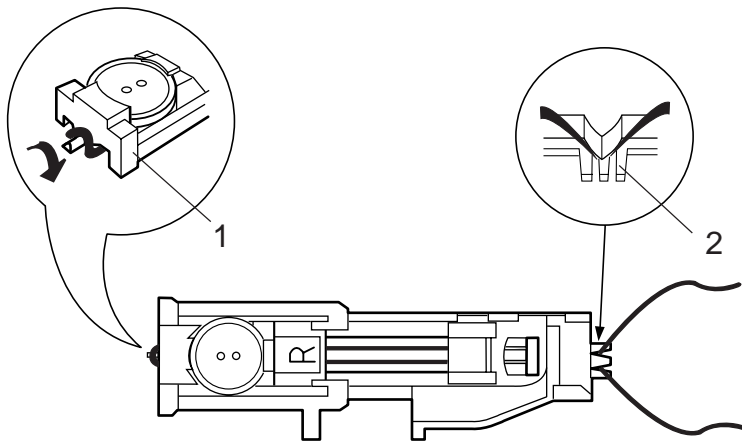

With the Automatic Buttonhole Foot **R** raised, hook the filler cord on the Spur on the back of the buttonhole foot.

Bring the ends of cord toward you under the buttonhole foot clearing the front end.

Hook the ends of the filler cord into the Forks on the front of the Automatic Buttonhole Foot **R**, to hold them tight.

- 1 Spur
- 2 Forks

Lower the needle into the garment where the buttonhole will start and lower the foot.

Press the Start/Stop Button and sew the buttonhole. Each side of the buttonhole and the bartacks will be sewn over the cord. The machine stops automatically when finished.

Remove the fabric from the machine and cut the sewing threads only.

Pull the left end of the filler cord to tighten it.

Thread the end of the cord through a darning needle and draw it to the wrong side of the fabric and cut.

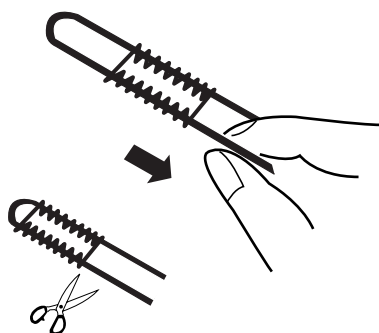
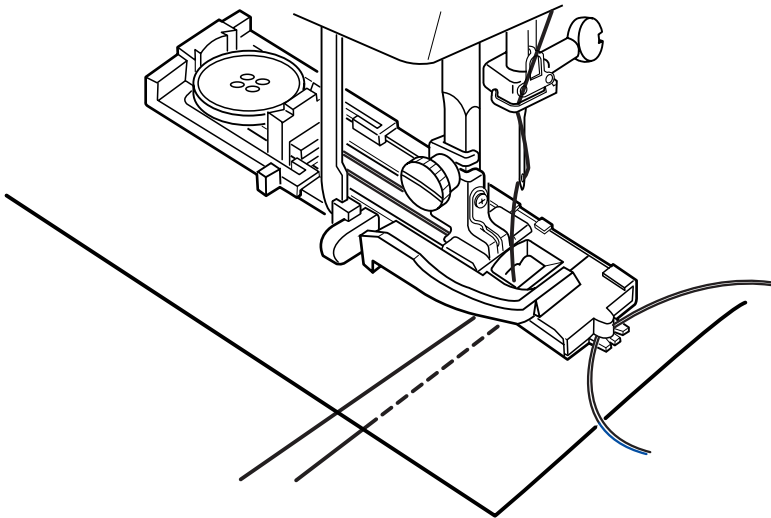

NOTES:

Set the stitch width in accordance with the thickness of the cord used.

To cut the buttonhole opening, refer to the instructions on page 45.

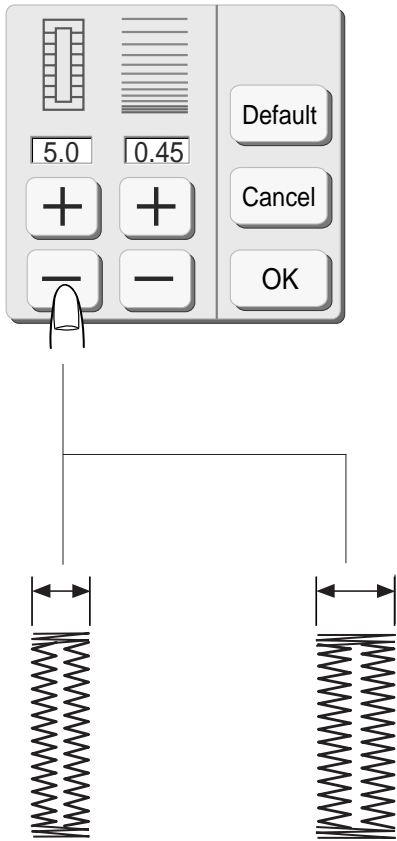

Changing buttonhole width

Press the Adjust key and the adjusting window will open.

Press the **+** key to increase the buttonhole width

Press the **-** key to decrease the buttonhole width

Press the OK key to register the settings.

NOTE:
Default setting is 5.0

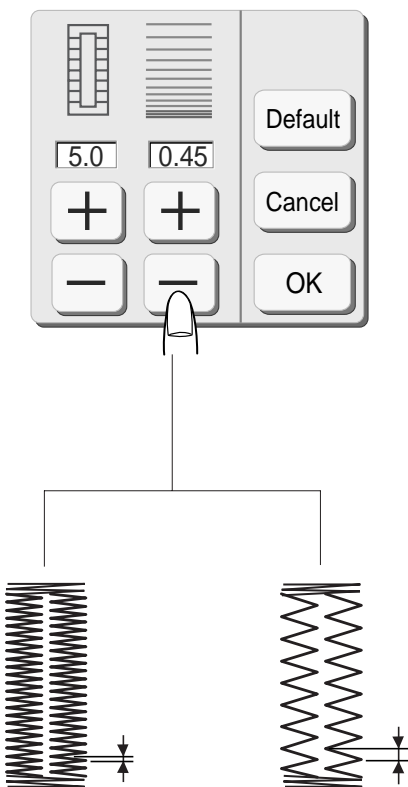

Changing buttonhole stitch density

Press the **+** key to make the buttonhole stitches coarser.

Press the **-** key to make the buttonhole stitches denser.

NOTE:
Default setting is 0.45

The manual settings will be canceled if you select other patterns or turn the power off.

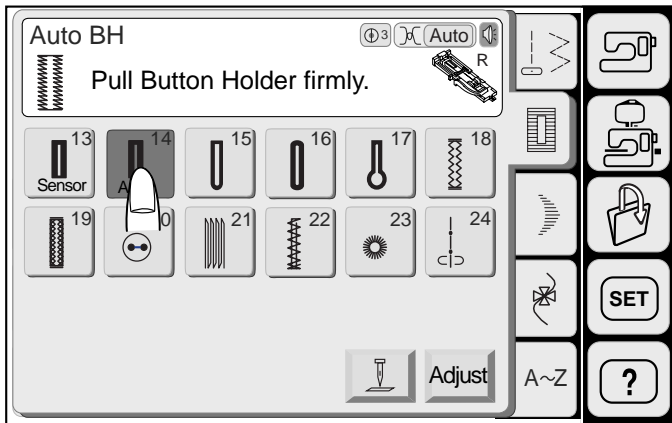

Automatic buttonhole

Select the pattern 14.

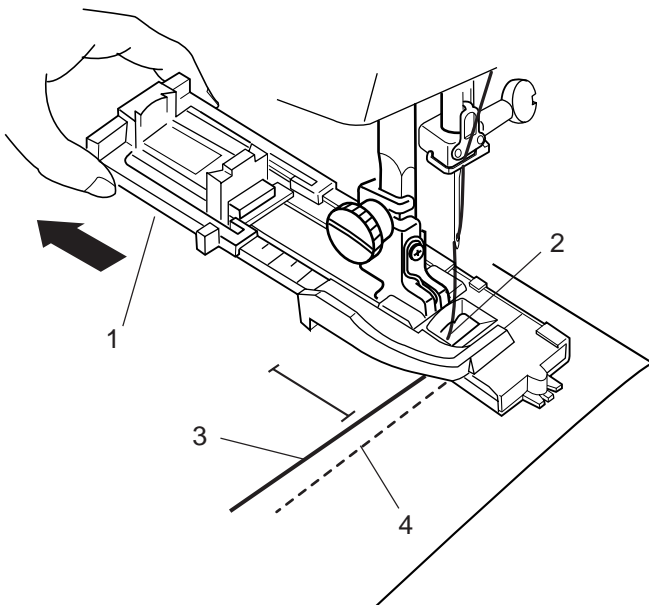

Attach the Automatic Buttonhole Foot **R**. Pull the Button Holder all the way out.

Mark the buttonhole position on the fabric. Insert the fabric under the foot. Press the Up/Down Needle Button twice. Remove the fabric to the left to draw the needle thread through the Hole of the foot.

Insert the garment under the foot, and lower the needle at the starting point. Then lower the Automatic Buttonhole Foot **R**.



- 1 Button Holder
- 2 Hole
- 3 Needle Thread
- 4 Bobbin Thread

NOTES:

You do not need to pull down the Buttonhole Lever. If you wish to change the buttonhole width and stitch density press the Adjust key.

If you wish to sew a buttonhole longer than the size permitted by the Automatic Buttonhole Foot **R**, use Satin Stitch Foot **F**.

Step1 Ⓞ3 [] Auto []

 Sew to length required, then press "↶". 

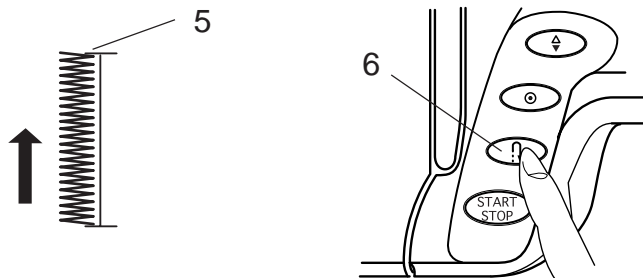



Step-1

Sew up the left side until the end of the buttonhole mark. Then press the Reverse Button.

- 5 Required Length
- 6 Reverse Button

Step2 Ⓞ3 [] Auto []

 Sew up to start Position, then press "↶". 

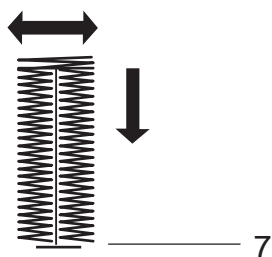

Step-2



Depress the Foot Control. The machine will automatically tack and sew down the right side of the buttonhole.

Stop the machine when you are directly opposite the Starting Point.

Press the Reverse button.

- 7 Starting Point

Step3 Ⓞ3 [] Auto []

 Machine stops when BH is completed. 

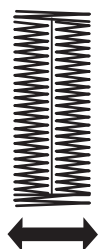

Restart for the Same Size.

Different size →

Step-3

Keep the Foot Control depressed. The machine will bartack, lock the stitches and automatically stop when the buttonhole is completed.

To make the next buttonhole, position the fabric and step down on the Foot Control.

To sew the next button hole in a different size press the Cancel button.

NOTE:

The MC 9500 will sew another buttonhole identical to the first one each time you step down on the Foot Control.

To cut the buttonhole opening, refer to the instructions on page 45.

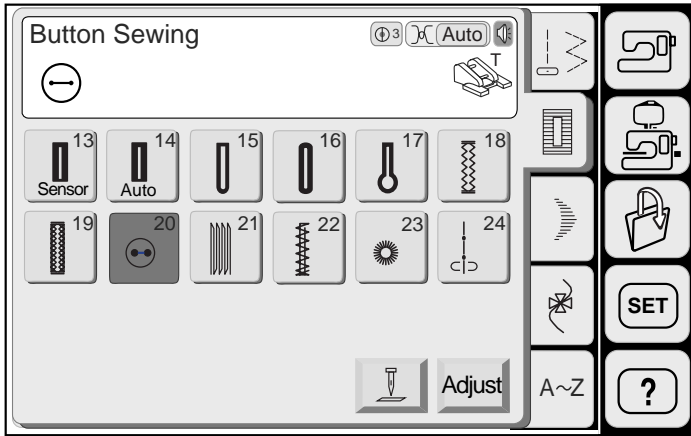

Button sewing

Select the pattern 20 and the feed dog will automatically drop.

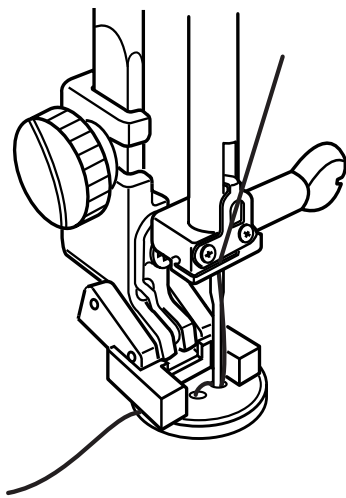

Place a button on the fabric and lower the needle by turning the handwheel with your hand, so that the needle enters through the left hole in the button.

Align the direction of the button and lower the Button Sewing Foot T to hold the button in place.

Press the Needle Up/Down Button to bring the needle up to the highest position. Adjust the stitch width, so that the zigzag width matches the span of the holes in the button.

Press the Start/Stop Button to sew and the machine will stop automatically.
Trim the Needle Thread at the Beginning.

1 Needle Thread at the Beginning

Raise the foot and remove the fabric. Cut both threads leaving a 2 cm (4") tail. Pull the bobbin thread to bring the needle thread down to the wrong side of the fabric then knot the threads.

- 2 Bobbin Thread
- 3 Needle Thread

NOTE:

The Feed Dog will be raised automatically after selecting other stitch patterns.

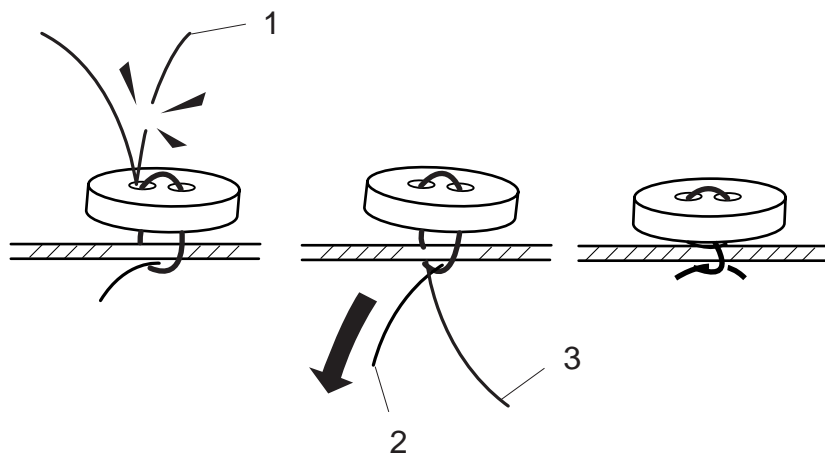

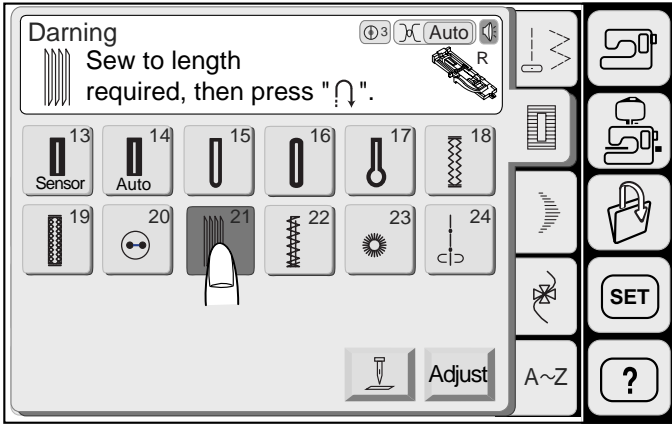

Darning

The Memory Craft 9500 automatically darns rips and holes. Large and small holes can be mended quickly and easily with this unique stitch.

Select the pattern 21.

Attach the Automatic Buttonhole Foot **R** and pull the Button Holder all the way out.

1 Button Holder

Depress the Foot Control to sew rows of darning, and a locking stitch. The machine stops automatically when completed.

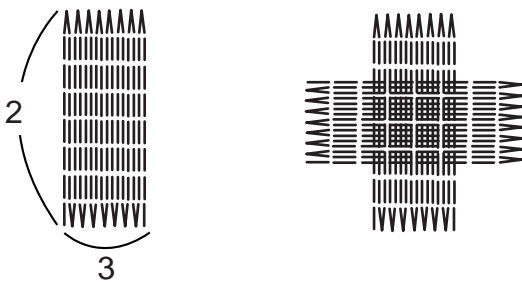
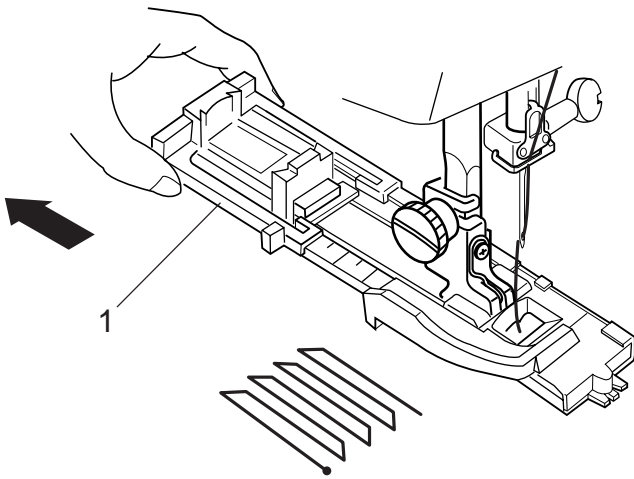

NOTE:

The maximum length of darning is 2 cm (3/4") and the maximum width is 0.7 cm (1/4").

- 2 2 cm (3/4")
- 3 0.7 cm (1/4")

Sew another layer of darning over the first layer, at a right angle to it.

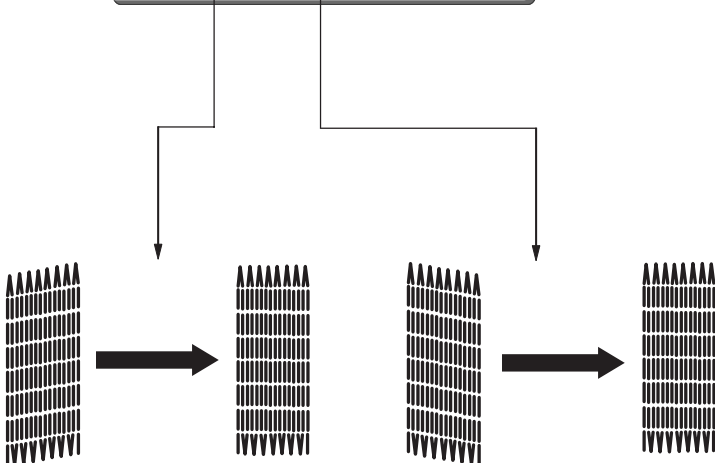
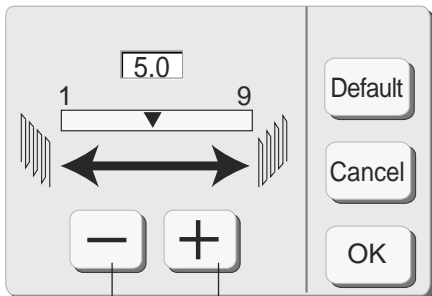
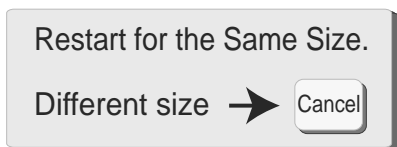
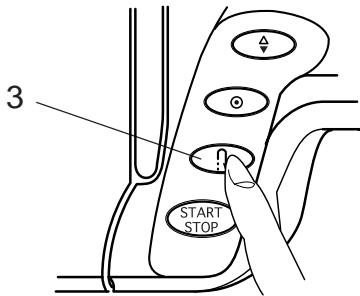
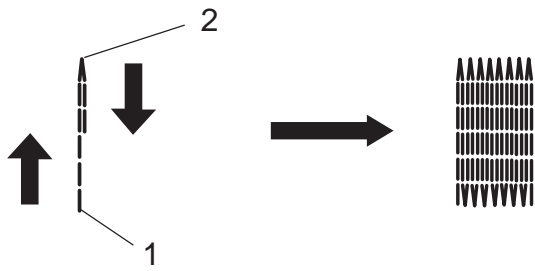

To sew a shorter darning

To sew a darning with a length of less than 2 cm (3/4"), first stop the machine after sewing the Required Length, then press the Reverse Button. The Required Length has now been determined.

Now restart the machine and continue sewing until the machine stops automatically.

- 1 Starting Point
- 2 Required Length
- 3 Reverse Button

To sew the same size darning

Simply restart the machine to sew another darning in the same size.

To sew the next darn in a different size, press the Cancel key.

To adjust the evenness of darning stitches:

You can correct the unevenness of darning by pressing the (+) or (-) key.

If the left corner is lower than the right side, press the + key to correct it, and vice versa.

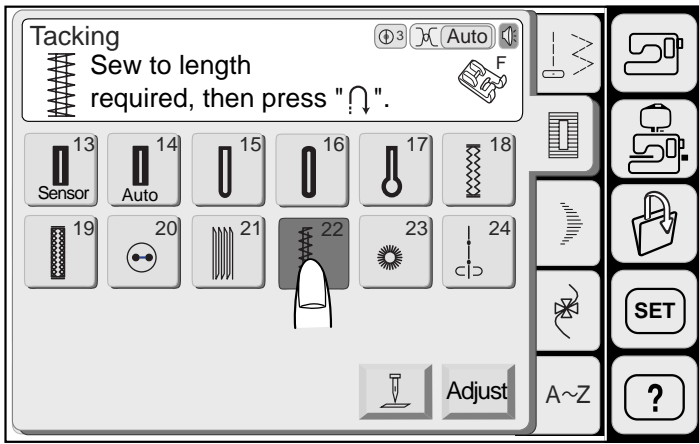

Tacking

Tacking is used to reinforce pockets, crotches and belt carriers where extra strength is needed.

Select Pattern 22 and attach the Satin Stitch Foot F.

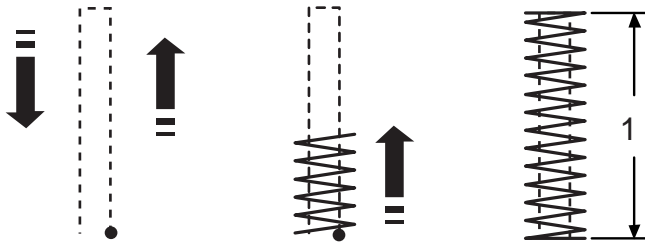

The machine will sew a tacking of 1.5 cm (9/16") long automatically.

1 1.5 cm (9/16")

NOTE:

Press the Adjust key to manually change the stitch length and stitch width.

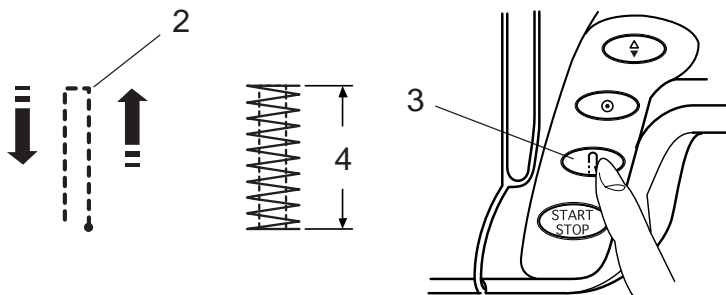
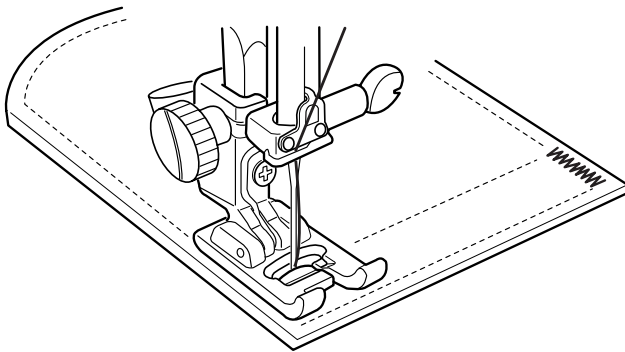

To sew a shorter tack

When you sew less than 1.5 cm (9/16") in length, sew to the Required Length and press the Reverse Button and the machine will memorize the Tack Length.

- 2 Required Length
- 3 Reverse Button
- 4 Tack Length.

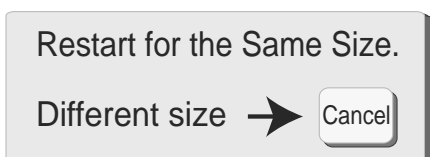

To sew the same size tack

To sew another tack in the same size, simply restart the machine and it will stop automatically when finish sewing.

To sew the next tack in a different size, press the Cancel key.

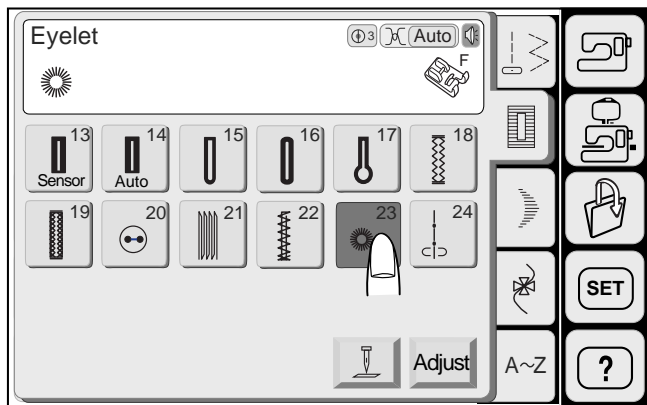

Eyelet

The Eyelet is used for belt holes etc.

Select the pattern 23 and attach the Satin Stitch Foot F.

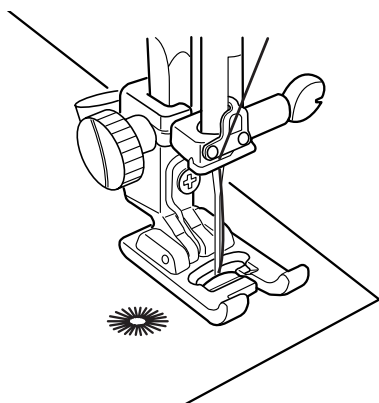

Depress the Foot Control to sew. The machine will stop automatically when completed.

Open the eyelet with an awl, puncher or pointed scissors.

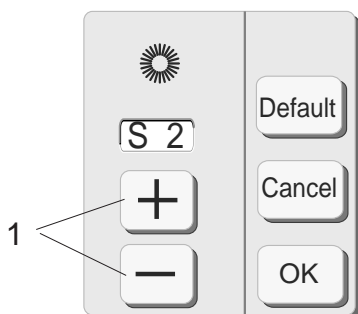

To adjust the shape of an eyelet:

If the eyelet opens, press the **-** key.

If the eyelet overlaps, press the **+** key.

1 Shape Adjusting keys

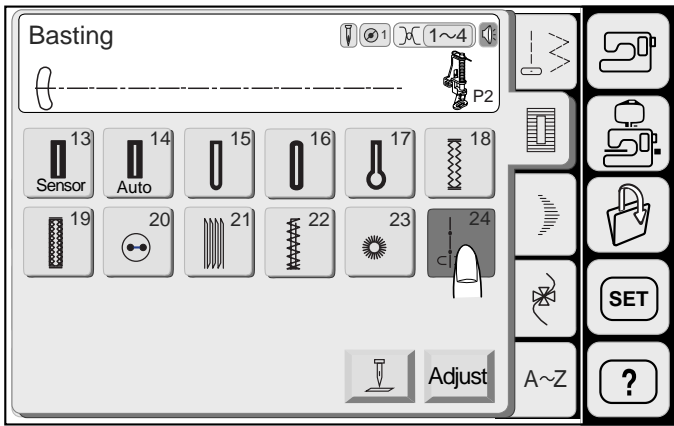

Basting

Select the pattern 24 and the feed dog will automatically drop.

Attach the Satin Stitch foot F or Darning Foot **P-2**.

NOTE:

Refer to page 10 for how to attach the Darning Foot **P-2**.

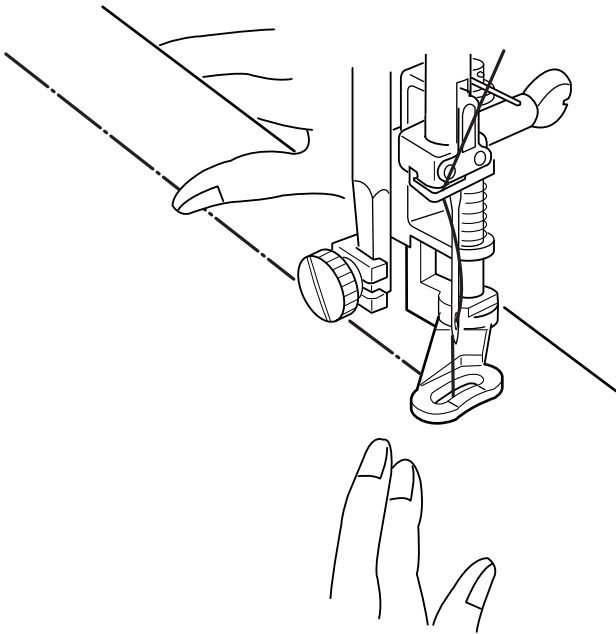

To sew

Hold the fabric taut and depress the Foot Control or press the Start/Stop Button.

The machine will take one stitch and stop automatically. Slide the fabric back for the next stitch.

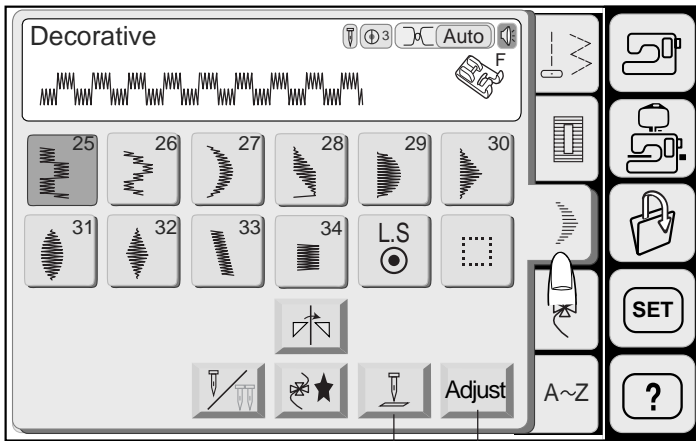

1 2

Satin Stitches

Press the Satin Stitch Key in the Ordinary Sewing Mode to open the Satin Stitch Window.

Function Keys:

- 1 **Needle Up/Down key:** Press the Needle Up/Down key to set the needle position up or down when stopping the machine.
- 2 **Adjust key:** Press the Adjust key to open the Manual Setting window.
- 3 **Zigzag Width:** Press the Zigzag Width **+** or **-** key to change the stitch widths.
- 4 **Stitch Length:** Press the Stitch Length **+** or **-** key to change the stitch length.
- 5 **Elongation key:** The Elongation key is used to change the elongation of decorative stitch patterns
- 6 **Default key:** When you press the Default key, all function values on the screen will return to the default settings (the same settings as when you purchased the machine).
- 7 **Cancel key:** When you press the Cancel key, the adjust window will close and the setting remains.
- 8 **OK key:** Press the OK key. The setting will be registered and the screen returns to the previous window.

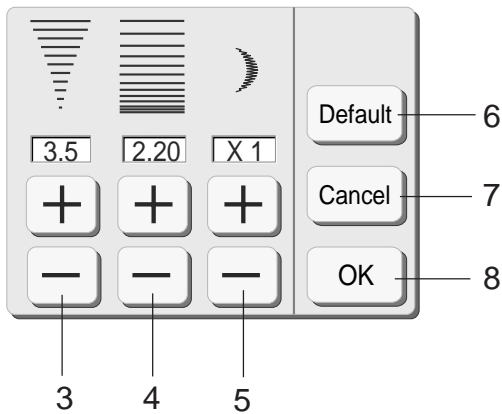

NOTE:

The manual settings will be canceled if you select other patterns or turn the power off.

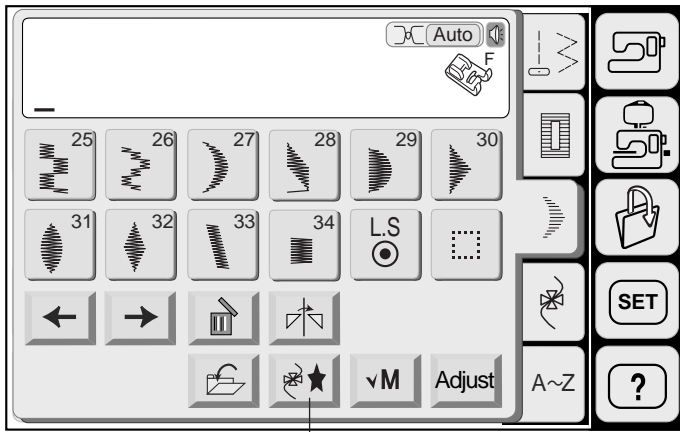

9

9 Program key

Press this key to program pattern combinations. When you press this key the Cursor keys, Delete key, Vertical Mirror key, "M" key (Memory Check key) and Save File key will be displayed.

10 Cursor keys

Press the Cursor keys to move the cursor to the right or left. Use these keys to select a pattern to delete or adjust.

11 Delete key

Press the Delete key to delete the selected pattern.

12 Vertical Mirror key

Press this key to memorize the mirror image pattern.

13 Save File key

Press this key to save the programmed pattern combination as a file.

NOTE:

You can save up to 100 files.

14 "M" key (Memory Check key)

Press this key to show the all the programmed patterns.

The key will change to " **B** " after starting the machine. Pressing this key allows you to sew the programmed patterns from the beginning.

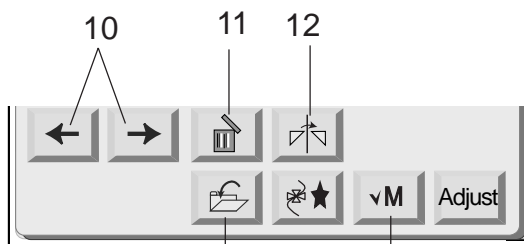

13

14

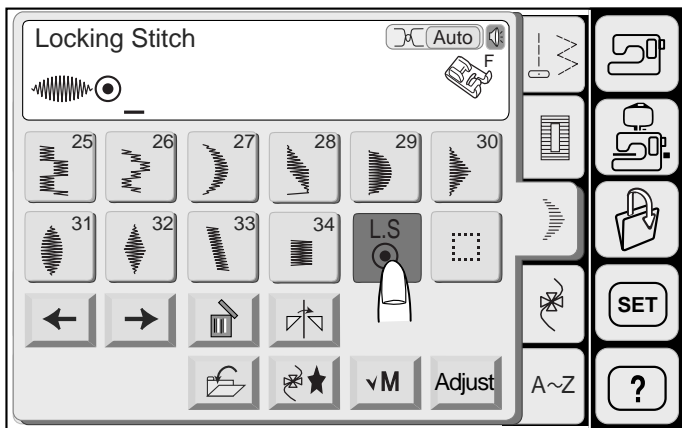

Single pattern with locking stitch

Press the program key.

Select the pattern 31.

Press the "L. S" key.

NOTE:

No more patterns can be memorized after pressing the "L. S" key.

The machine will sew a single pattern only and lock the stitch at the end then stop automatically.

1 Locking Stitches

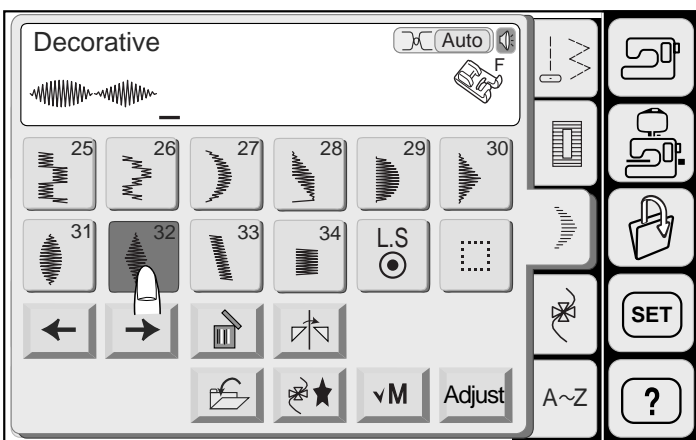
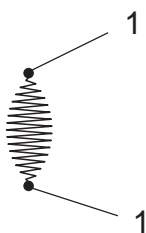

Programming a pattern combination

Press the program key.

Select the pattern 31.

Select the pattern 32

The machine will sew the pattern combination repeatedly.

NOTE:

If you press the Auto-Lock button in the middle of sewing, the machine will automatically stop after the current pattern is completed.

2 Auto-Lock button

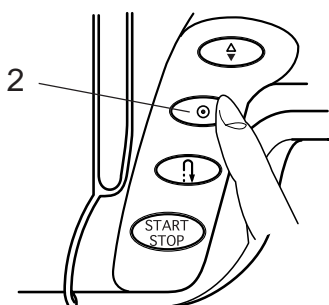

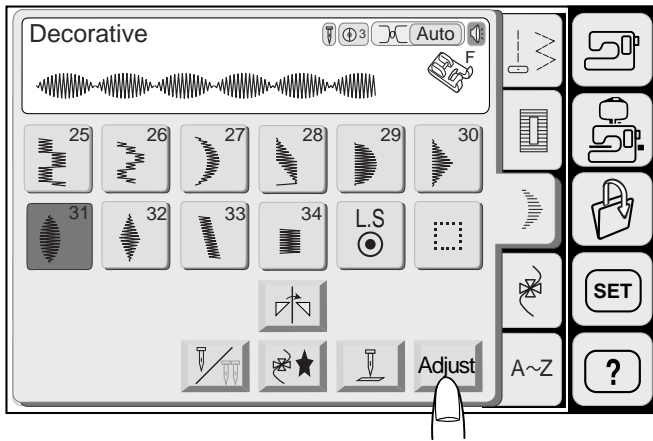

Elongation sewing

Example: Pattern 31

Select Pattern 31.

Press the Adjust key.

Press the Elongation **+** or **-** keys to set the desired stitch length.

NOTE:

The Elongation ratio is indicated in multiples of the original pattern length.

Press the OK key. The setting will be registered and the screen returns to the previous window.

Start to sew.

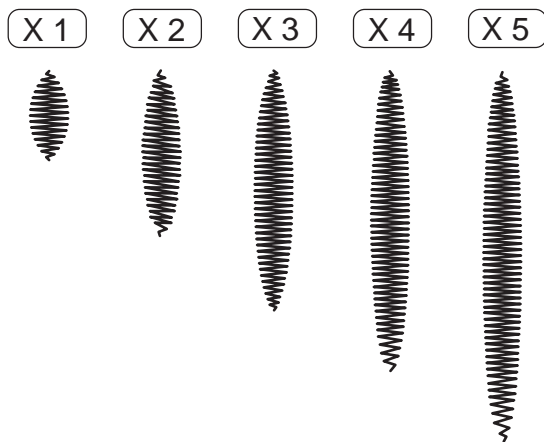
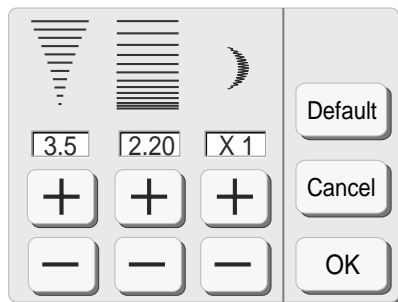

NOTE:

If you press the Auto-Lock Button in the middle of a programmed pattern the machine will stop automatically after the current pattern is completed.

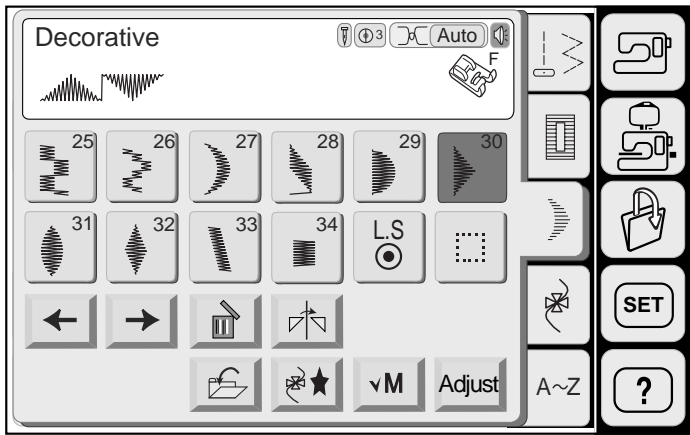

Programming a pattern combination with mirror image

Example: Pattern 30 and its mirror image

Press the Program key

Select the Pattern 30.

Press the Mirror Image key.

Select the Pattern 30.

Start to sew.

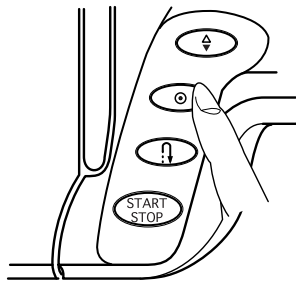

NOTE:

If you press the Auto-Lock Button in the middle of a programmed pattern the machine will stop automatically after the current pattern is completed.

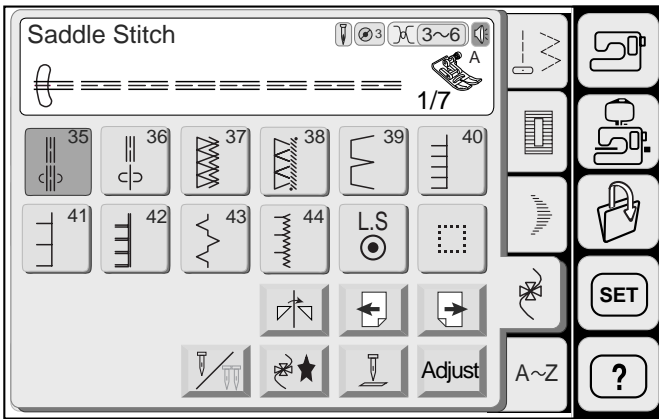

Decorative Stitches

There are 7 pages of decorative stitches in this category.

Press the Next Page  key to view the next page.

Press the Previous Page  key to view the previous page.

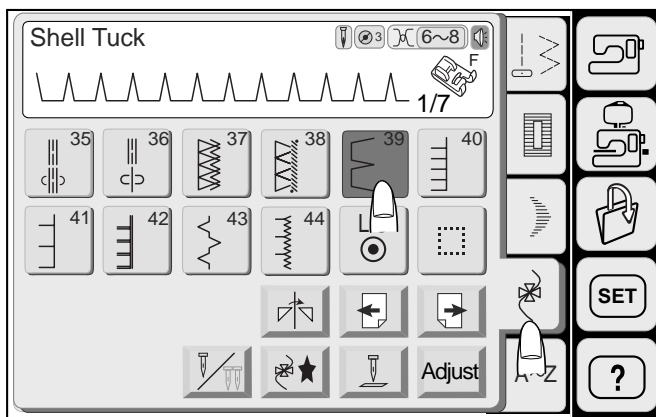

Shell Tuck Stitch

Select the pattern 39 on the Visual Touch Screen.

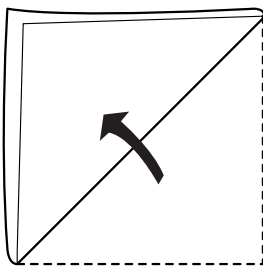

Use a lightweight fabric such as tricot.
Fold and stitch on the bias.

Attach Satin Stitch Foot **F**.
Increase the needle thread tension to 6-8.

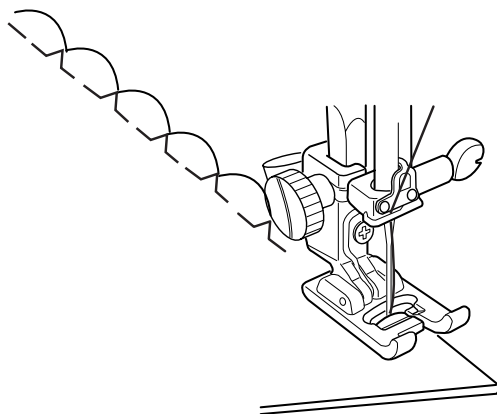

Place the folded edge of the fabric along the slit of the foot so that the right swing of the needle falls off the edge of the fabric to form tucks.

NOTES:

You can sew shell tucks on knits or soft silky woven in any direction.
If you sew rows of shell stitches, space the rows 1.5 cm (5/8") apart.

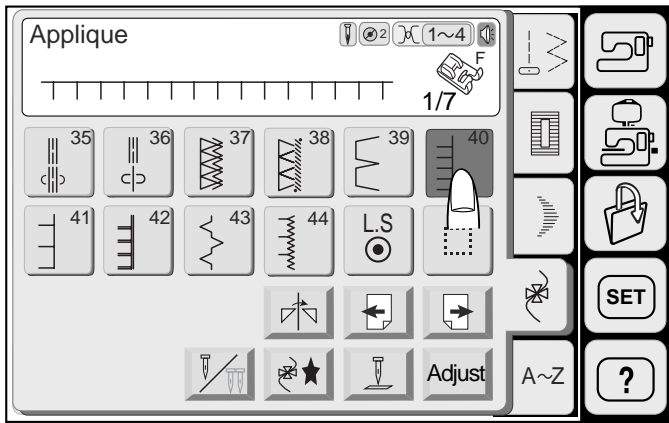

Applique sewing

Select the pattern 40.

Attach the Satin Stitch Foot F.

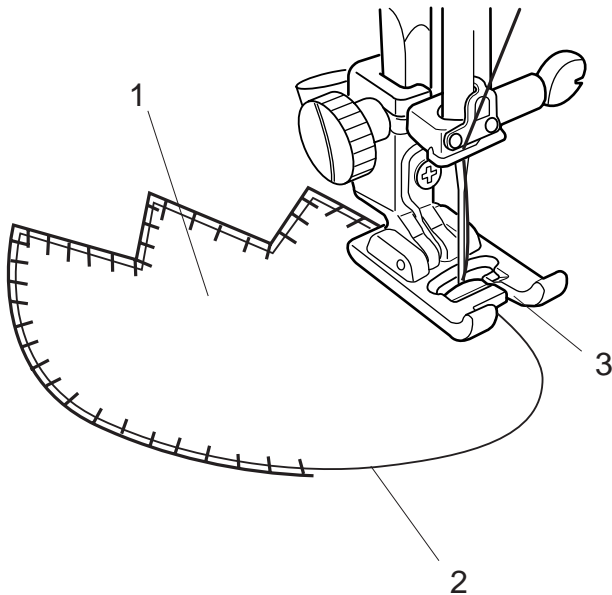

Place the Applique on the fabric and baste it in place. Sew guiding the edge of the applique along the Slit on the foot, so that the needle falls off the Edge of the Applique when it swings to the right.

- 1 Applique
- 2 Edge of the Applique
- 3 Slit

NOTE:

When changing the sewing direction at a corner or curve, lower the needle into the applique at the left swing and turn the fabric to a new direction.

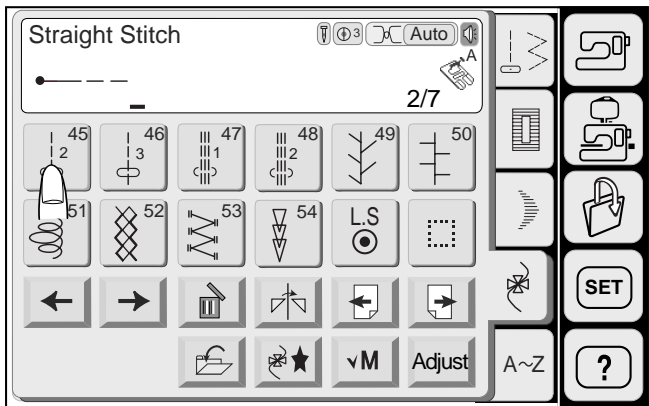
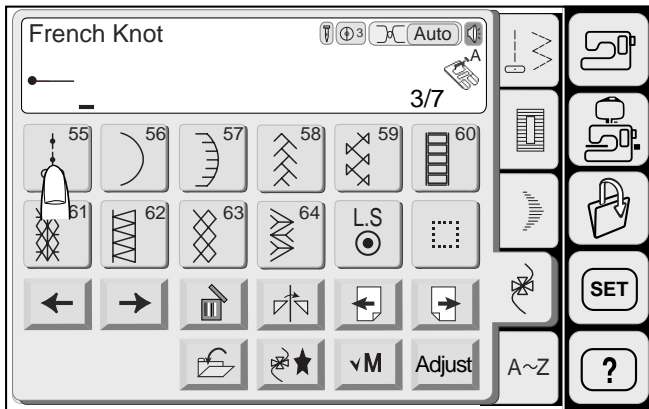

Programming French knot

Example: Pattern 55, Pattern 45, Pattern 55 and Pattern 46

Press the program key.

Select the pattern 55 (French knot).

Press the previous page key to show page 2/7.

Select the pattern 45. Two counts of straight stitch will be memorized.

Press the next page key to show page 3/7.

Select the pattern 55.

Press the previous page key to show page 2/7.

Select the pattern 46. Three counts of straight stitch will be memorized.

Start to sew. The machine will sew the programmed French knots repeatedly.

NOTE:

If you press the Auto-Lock Button in the middle of a programmed pattern the machine will stop automatically after the current pattern is completed.

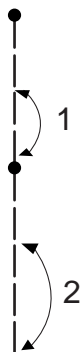

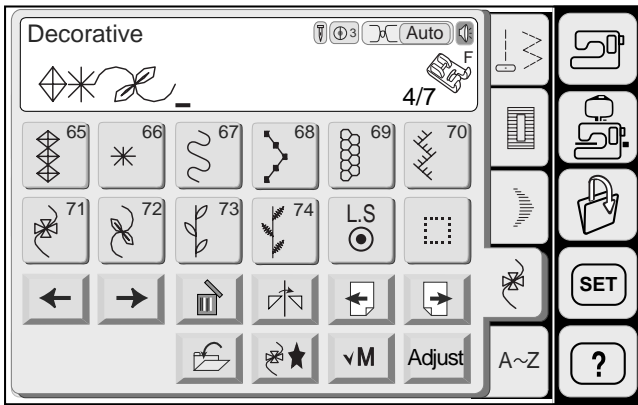

Sewing the pattern combination from the beginning

After you start sewing, the “M” (Memory check) key will change to the **B** (Beginning) key. Press this key if you stop sewing in the middle of the pattern combination and wish to sew it again from the beginning.

Example: Combination of the patterns 65, 66 and 72

Start sewing.

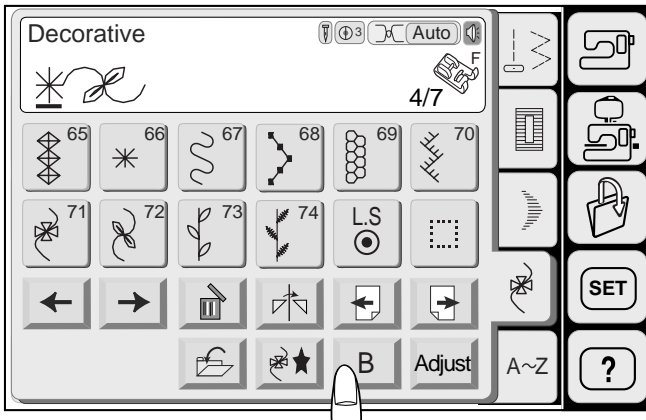

Stop the machine in the middle of sewing the pattern 66.

The screen shows the patterns 66 and 72.

Press the **B** key.



The screen shows the pattern combination with the pattern 65 at the head.

The machine will sew the pattern combination from the beginning.

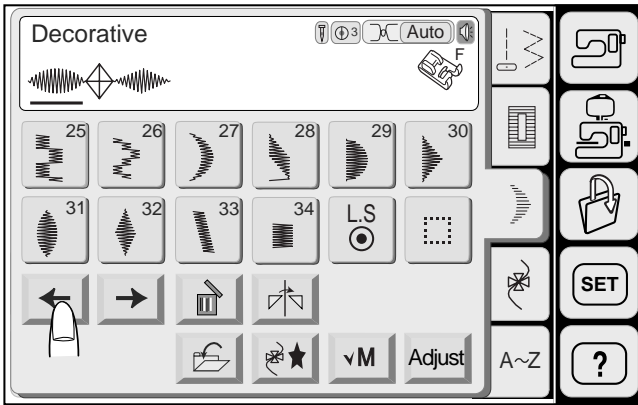

Individual pattern adjustment

You can adjust the zigzag width, stitch length and elongation ratio of each patterns in a combination individually.

Example: Changing the elongation ratio of the pattern 31 in combination with the patterns 65 and 32.

Press the Left Arrow key to move the cursor below the pattern 31.

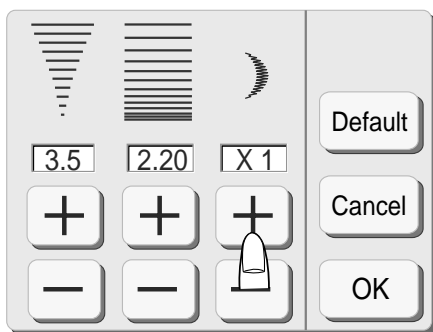

Press the Adjust key.

Change the elongation ratio by pressing the Plus (+) or Minus (-) key.

Press the OK key to register the adjustment and the screen will go back to the previous display.

Start to sew.

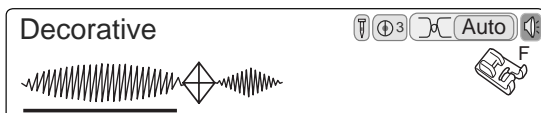

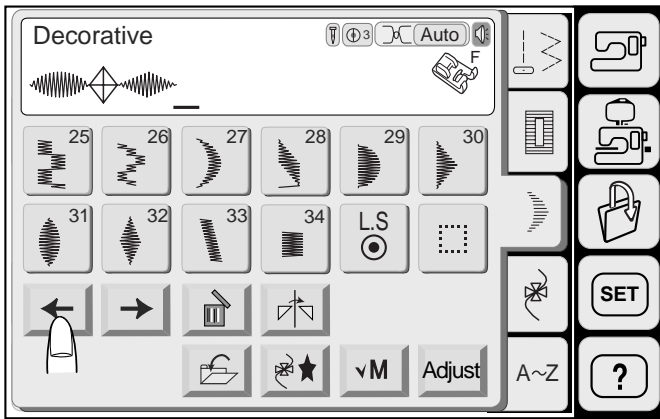

Editing Programmed Patterns

Example: When the patterns 31, 65 and 32 are memorized.

Deleting the pattern 65

Press the Cursor key to move the cursor under the pattern 65.

Press the Delete  key.



The pattern 65 will be deleted.

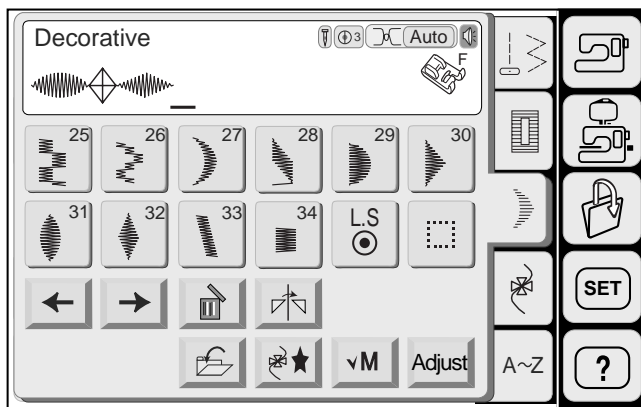

Inserting the pattern 66

Press the Cursor key to move the cursor under the pattern 32.



Select the pattern 66.

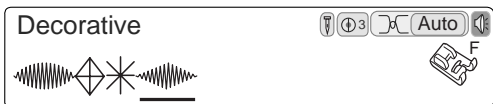

The pattern 66 will be inserted before the pattern 32.

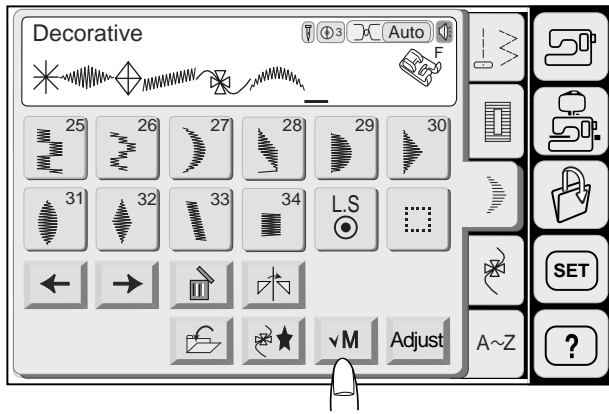

Program check

Pressing the “M” (Memory check) key will display the entire pattern combination.

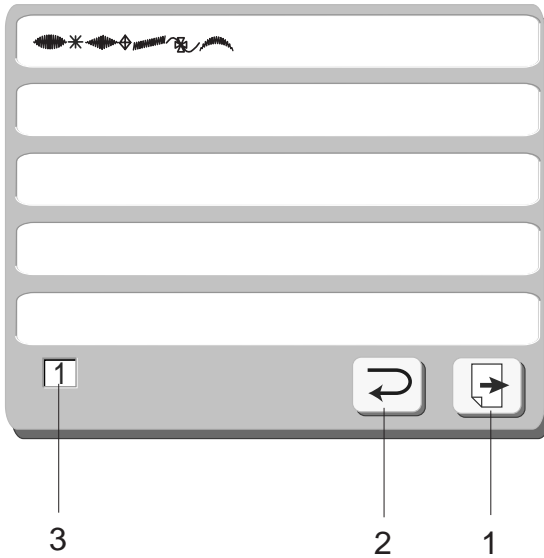

If the pattern combination is too long to show, press the Next Page key to view the remaining patterns in combination.

Press the Return Key to go back to the original window.

- 1 Next Page Key
- 2 Return Key
- 3 Page Number

Twin Needle Sewing

NOTE:

When you sew patterns with the twin needle, test the stitches first before you sew.

Use the Zigzag Foot **A** or Satin Stitch Foot **F** for Twin Needle Sewing.

Turn the power switch off before changing the needle.

Select the pattern then press the Twin Needle key.

1 Twin Needle Key

If the selected pattern is not suitable for twin needle sewing, the Twin Needle key will gray out and be disabled.

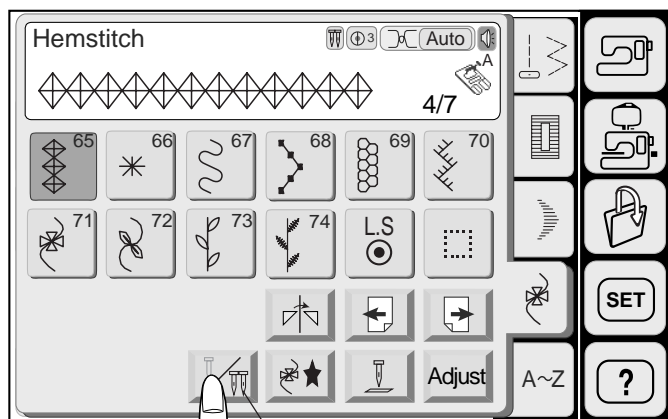

1

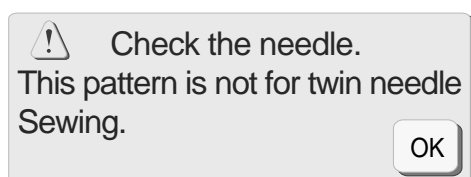
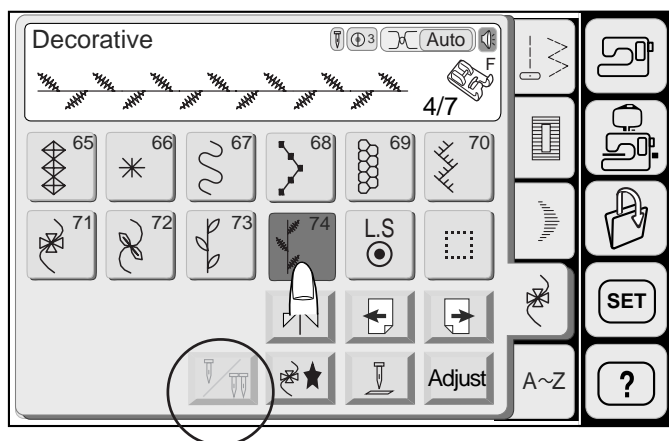

A warning message will appear if you select a pattern that is not suitable for twin needle sewing after pressing the Twin Needle key.

Press the OK key to return to the previous screen.

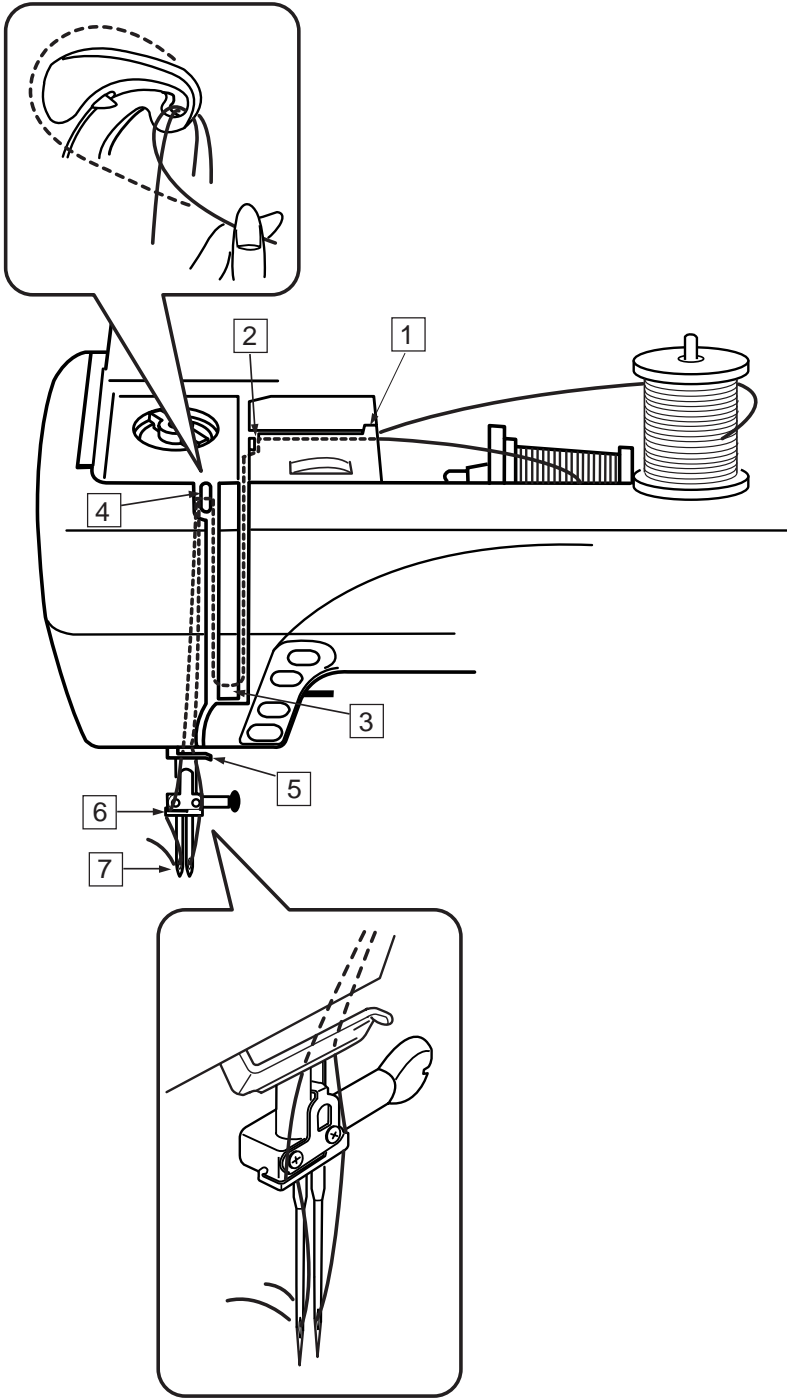

Insert an additional spool pin, and put a felt and spool on it.

Draw both threads from the spools and pass them through the threading points from 1 to 5. Make sure that the two strings of thread from the spools do not get tangled.

NOTES:

Make sure each threads wind off from the spools as shown. Threading from points 1 to 5 is the same as for a single needle.

Slip one of the threads through the needle bar thread guide on the left, and the other one on the right.

Thread the needles from the front to back.

NOTES:

The Built-in Needle Threader cannot be used for the twin needle. When changing the sewing direction, raise the needle and turn the fabric.

Monogramming

You can combine letters and symbols for monogramming.

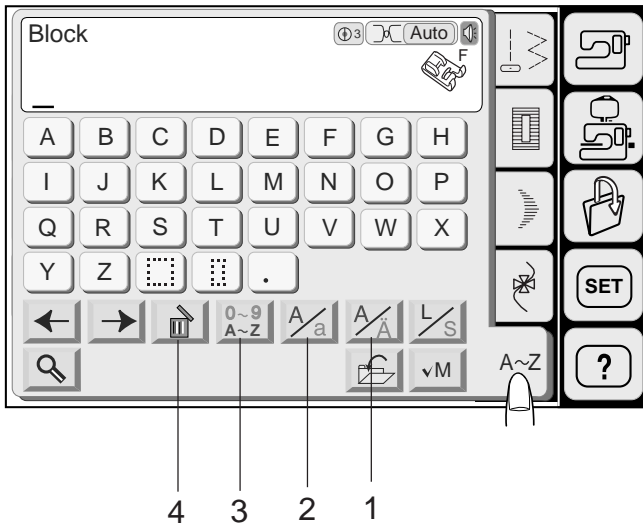

1 European Accented Letter key

You can select the European Accented Letters, such as the diaeresis.

Pressing the **A/a** key will select the Alphabet or European Accented Letters alternately.

2 Upper/Lower Case key

You can select Upper or Lower Case Letters

Pressing the "A/a" key will select upper or lower case letters alternately.

3 Letter/Number Key

You can select Numbers and Symbols.

Pressing the Letter/Number key will select the Letters or Numbers alternately.

4 Delete key

Press this key to delete the pattern or monogram with the cursor under it.

5 Cursor key

This key is for editing your monogram

Press the Left arrow key to move the cursor to the left. Press the Right arrow key to move the cursor to the Right.

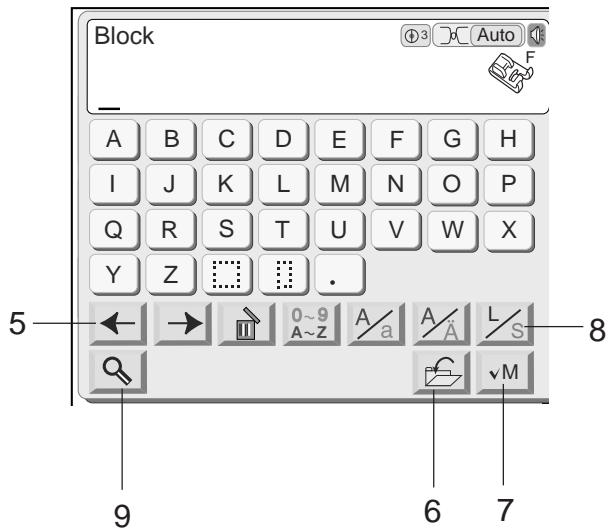

6 File Save key

You can save the programmed pattern combination as a file.

7 Memory Check key

Pressing the "M" (Memory check) key will display the entire pattern combination.

After starting the machine, the key will change to the **B** key.

8 Letter Size key

By pressing this key, the size of the letter will change to approximately 2/3 of the full size letter. If you press it again, the letter will go back to the original size.

9 Magnifier key

Pressing this key enlarges the Letter/Number keys to make entry easier.

Press the Return  key to return to the original screen.

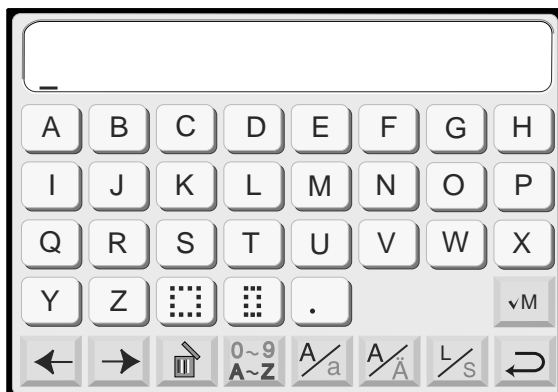

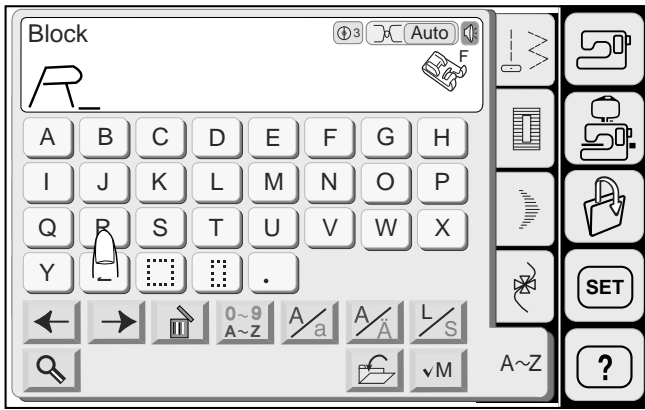

Programming a monogram

Example: Programming "R&B"

Press the Upper/Lower Case **A/a** key to select Upper Case.

Press the Letter Size **L/s** key to select Large Size.

Press "R", and the cursor shifts to the right and "R" is automatically memorized.

Press the Letter/Number **0-9** key to select the Numbers.

Press the Letter Size **L/s** key to select Small Size.

Press "&", and the cursor shifts to the right and "&" is automatically memorized.

Press the Letter/Number **0-9** key to select the Letters.

Press the Letter Size **L/s** key to select Large Size.

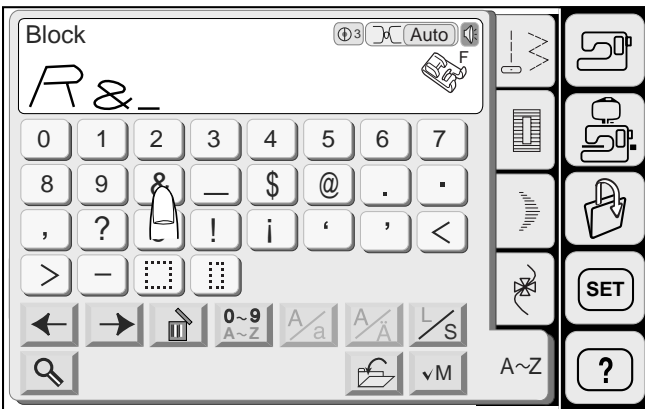

Press "B", the cursor shifts to the right and "B" is automatically memorized.

The machine will sew the monogram and stop automatically when finished.

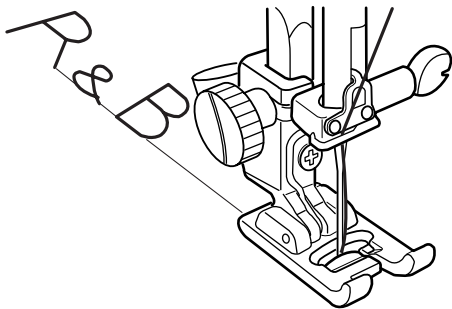
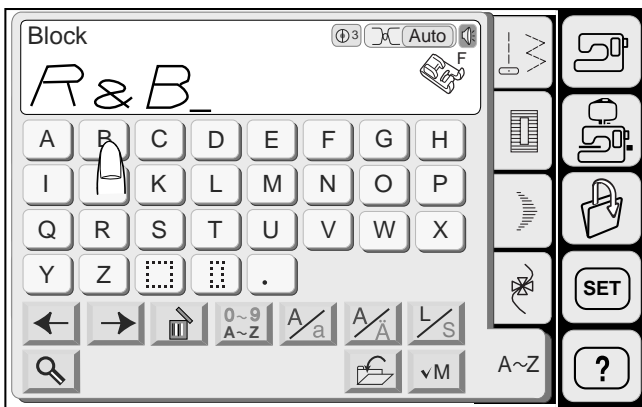

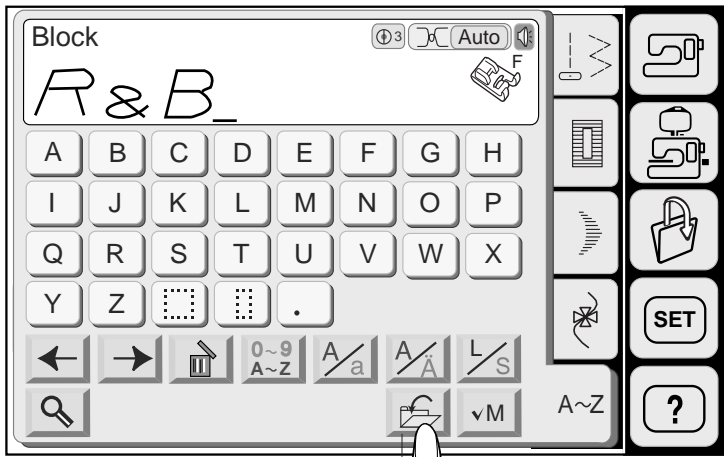

1

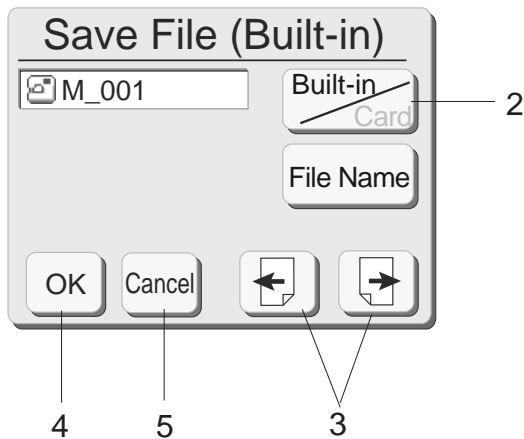

4

5

3

Saving and Opening a File



Saving a file

Press the Save File key and the Save File window will open.

1 Save File key

You can select the location to where you want to save the file. Press the Built-in/Card  key, to select the location either in the internal memory of the sewing machine or a PC Card inserted in the machine's card slot.

2 Built-in/Card Key

A list of the saved files will be displayed. If there is more than one page to the list, press the Next  or Previous  Page key to view the complete list.

3 Page Keys

Press the OK  key to save the file and the screen will return to the previous screen.

4 OK Key



Press the Cancel  key to return to the previous screen without saving the file.

5 Cancel Key

NOTE:

The file name will be automatically assigned starting from M_001 in order.

CAUTION:

Do not turn the power off or eject the card when the warning sign   or hourglass is shown on the visual touch screen. Otherwise, data stored in the memory may be lost or damaged.

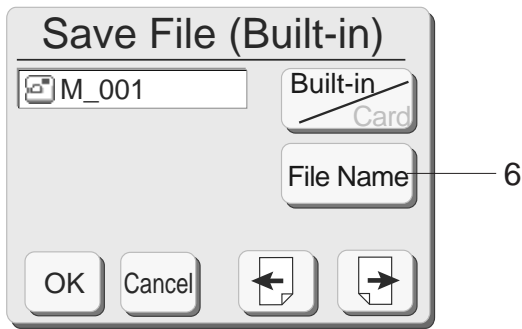

Assigning a file name

You can assign a file name in the file name window.
Press the File Name  key to open the file name window.

6 File Name Key

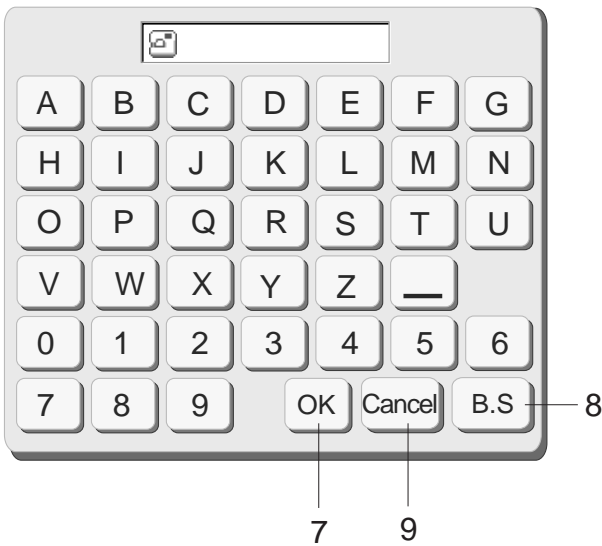

The character keys are displayed in the window.

Enter the file name and press the OK  key.

7 OK Key

The screen will return to the save file screen.
Press the OK key in the file save window and the file will be saved with the new name.

NOTE:

Only 8 characters can be entered.

Press the Back Space  key to delete the last character.

Press the Cancel  key and the screen will return to the file save window.

8 Back Space Key

9 Cancel Key

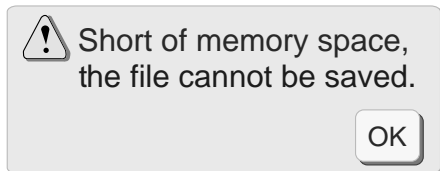

NOTES:

When the memory is full, a warning message will appear. Press the OK  key and go to the open file window then delete the files that you do not need.

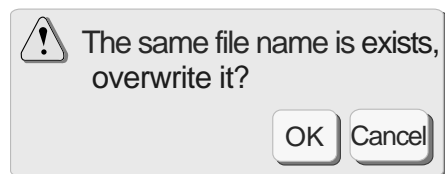

When you save the file under the existing name, a warning message will appear.

Press the OK  key to overwrite the existing file.

Press the Cancel  key if you do not wish to overwrite it.

You may need to change the file name and save the file under the different name.

Correcting Distorted Stretch Patterns

The sewing results of the stretch stitch patterns may vary depending upon the sewing conditions, such as sewing speed, type of the fabric, number of layers etc. Always make a test sewing on a scrap piece of the fabric that you wish to use. If decorative stretch stitch patterns, letters, numbers or the Auto Buttonhole stitch are distorted, correct it with the Feed Balancing Dial.

NOTES:

In normal sewing, set the Feed Balancing Dial to the neutral position, i.e. the Groove on the Dial is centered with the Standard setting Mark. Turn the Feed Balancing Dial with a coin.

- 1 Feed Balancing Dial
- 2 Standard Setting Mark
- 3 Groove on the Dial

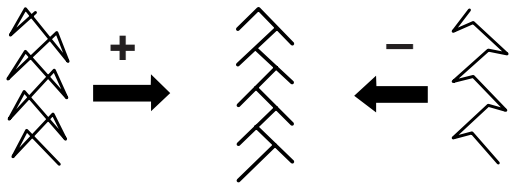
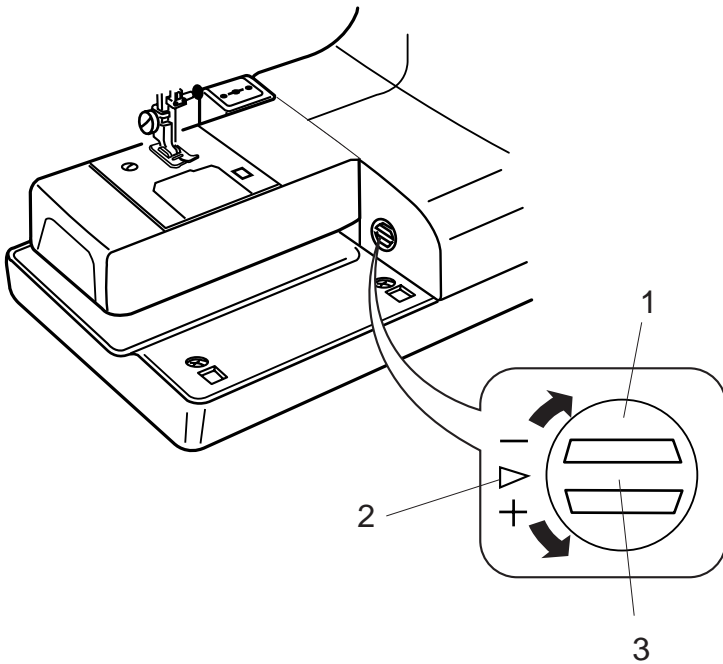

Decorative stretch stitch patterns

If the pattern is compressed, turn the dial toward “+”.
If the pattern is drawn out, turn the dial toward “-”.

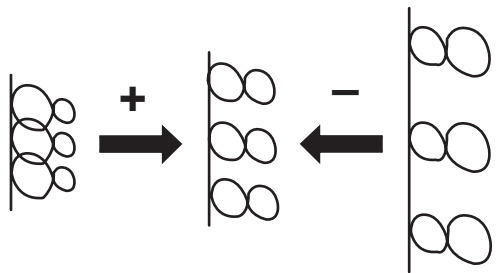

Letters and numbers

If the pattern is compressed, turn the dial toward “+”.
If the pattern is drawn out, turn the dial toward “-”.

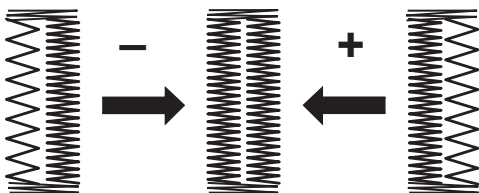

Correcting stitch balance of the Auto Buttonhole

The stitch balance of the right and left rows on the Auto Buttonhole may vary depending on conditions of sewing. If the stitches are not balanced, correct the unevenness with the Feed Balancing Dial.

If the right row is denser, turn the dial toward “-”.
If the left row is denser, turn the dial toward “+”.

NOTE:

Return the Feed Balancing Dial to its neutral position when sewing is finished.

EMBROIDERY MODE

Embroidery Hoops

Embroidery Hoop A:

This is the standard size hoop, with a 12.6 cm (5") by 11 cm (4 3/8") embroidery area for sewing PC Card embroidery designs etc.

- 1 Outer Hoop
- 2 Inner Hoop
- 3 Attaching Knob
- 4 Hoop Tightening Screw

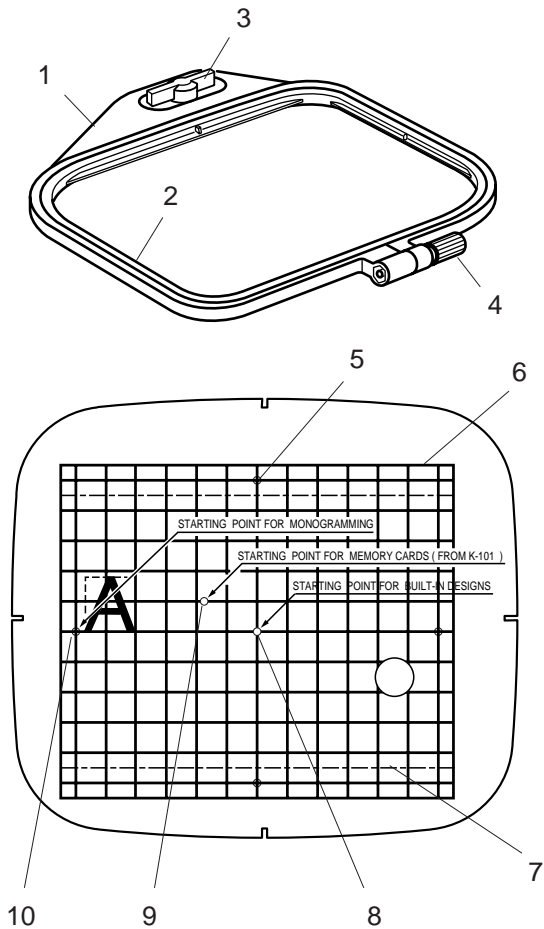

Template for Embroidery Hoop (A)

- 5 Starting Point for Monogram in Vertical Orientation
- 6 ■ Indicates the embroidery boundary for built-in designs, PC Design Card Nos. 1001 and up.
- 7 □ Indicates the embroidery boundary for Memory Card No. 102 and up.
- 8 Starting Point for Built-in designs and monograms
- 9 Starting Point for the designs from Memory Card Nos. 102 and up
- 10 Starting Point for Monogramming in Horizontal orientation.

Embroidery Hoop B:

This is the large-size hoop, with a 20 cm (8") by 14 cm (5 1/2") embroidery area for sewing large-size designs and combined designs.

- 1 Outer Hoop
- 2 Inner Hoop
- 3 Attaching Knob
- 4 Hoop Tightening Screw

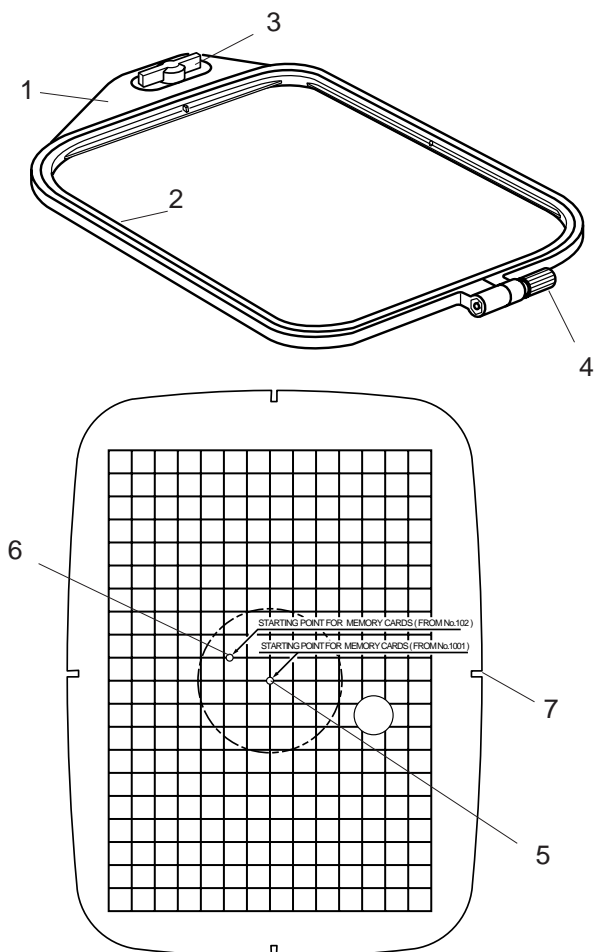

Template for Embroidery Hoop (B)

- 5 Starting Point for Built-in designs and monograms
- 6 Starting Point for the designs from Memory Card Nos. 102 and up
- 7 Indentations for Positioning the Template

NOTE:

The four indentations on the template do not correspond with reference lines.

Stabilizers

To obtain the best quality embroidery, it is important to use stabilizers.

Types of stabilizer

Tear-away Stabilizer is made from a fiber that will tear easily. Use tear-away stabilizers for stable woven fabrics. After stitching, tear away the stabilizer so that the small portion left in the back of the stitching will not affect the wear. **Iron-on Stabilizer** is an adhesive type stabilizer for knits and all kinds of unstable fabrics. Fuse it to the wrong side of the fabrics with an iron.

Cut-away Stabilizer is a non-woven fabric that does not tear. Cut the excess portion after stitching. Use cut-away stabilizers for knits and all kinds of unstable fabrics.

Water Soluble Stabilizer will dissolve in water. Use this stabilizer for cutwork or lace embroidery, and also for the right side of looped fabrics such as towel to avoid loops coming through the embroidery.

Sticky Stabilizer is a sticky paper used for securing a small fabric or work that cannot be secured in the hoop. It is also used for velvet and other napped fabric that would be permanently marked by the hoop.

Usage:

The stabilizer should be attached to the wrong side of fabric.

More than one layer may be required.

Felt or stable fabrics do not need to be stabilized and you may embroider directly on it.

For firm fabrics, you may place a thin paper under the fabric.

The non-adhesive type should be used when embroidering fabric, which cannot be ironed or for sections, which are difficult to iron.

Cut the stabilizer larger than the embroidery hoop and set it on the hoop so that the entire piece is fastened with the hoop to prevent looseness of the fabric.

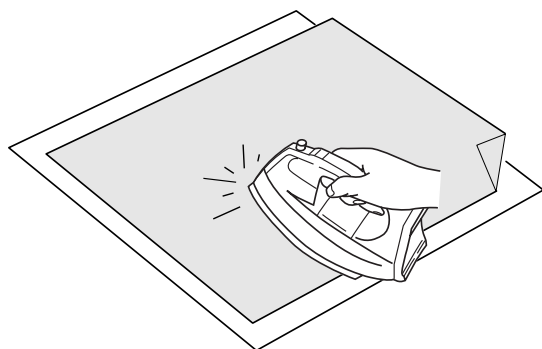

Adhesive (Iron-on) Stabilizer

Place the Wrong side of fabric and the glossy side of the stabilizer together. Fold up a corner of the stabilizer and fuse it with an iron.

NOTES:

Fold up a corner of the stabilizer to make it easier to peel off the excess stabilizer after stitching.

Ironing temperatures vary depending on the kind of adhesive type stabilizer.

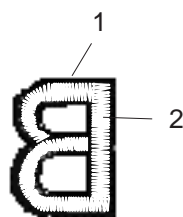

Adjusting the Thread Tension

Balanced thread tension:

A small amount of the needle thread shows on the wrong side of the fabric.

- 1 Needle Thread
- 2 Bobbin thread

When the needle thread tension is too tight:

The bobbin thread shows on the right side of the fabric.

Reduce the tension by turning the tension dial to a lower number.

When the needle tension is too loose:

The needle thread forms loops and the stitches look shaggy.

Increase the tension by turning the dial to a higher number.

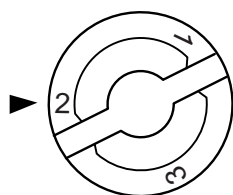

Pressure Dial

For embroidery, set the Pressure Dial at "2".

Needles

Use size 11 needles for fine fabrics.

For medium to heavy weight fabrics, use size 14 needles.

Setting the Fabric in an Embroidery Hoop

1

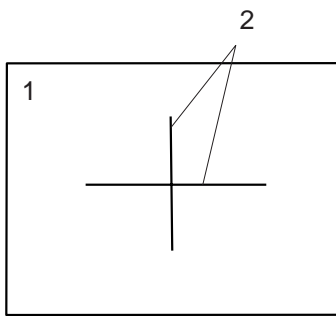

2

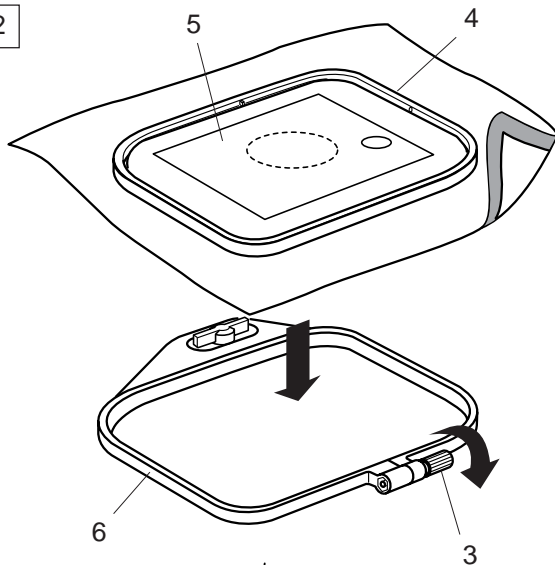

3

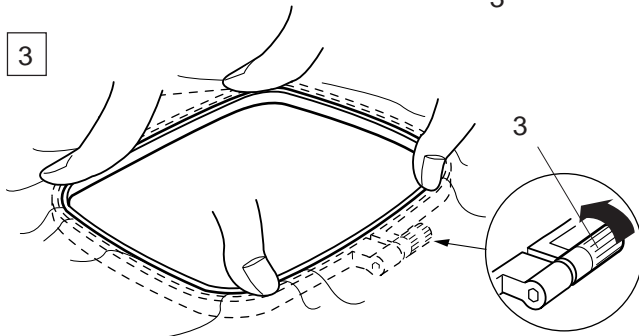

4

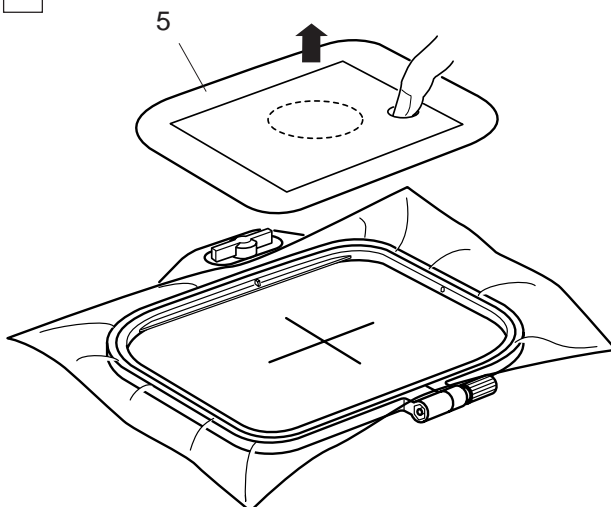

1 Mark the Centerlines on the right side of the fabric with tailor's chalk.

2 Loosen the Hoop Tightening Screw on the outer hoop.
Lay the inner hoop and template on the fabric, matching the centerlines.

3 Push them into the outer hoop.

Tighten the screw on the outer hoop to stretch the fabric. Make sure that the fabric is stretched drum-tight in the hoop.

4 Remove the template.

- 1 Fabric
- 2 Centerlines
- 3 Hoop Tightening Screw
- 4 Inner Hoop
- 5 Template
- 6 Outer Hoop

NOTES:

When placing the fabric on the Embroidery Hoop, place the Outer Hoop on a flat surface.
For thin and stretchy fabrics use an adhesive type Stabilizer (iron-on type) on the wrong side of the fabric. More than one layer may be required.

Attaching the Embroidery Hoop to the Machine

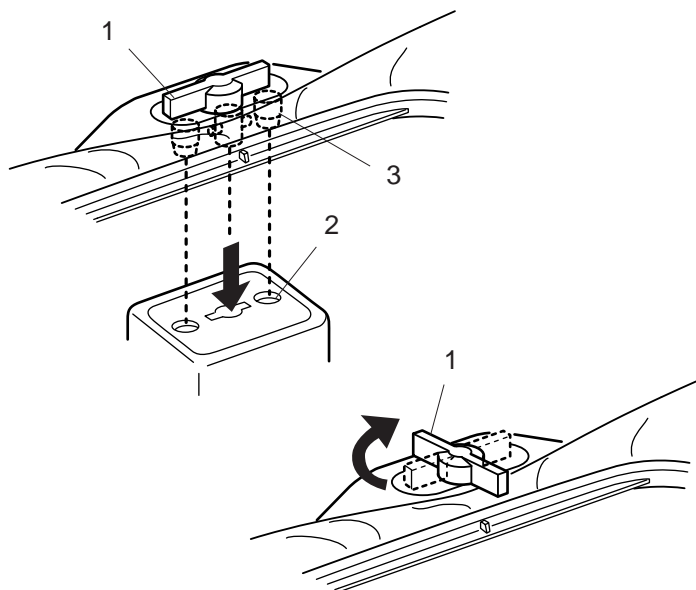

Turn the Attaching Knob so it is parallel with the metal plate, and set the hoop on the Carriage. Attach the hoop by fitting the Pins into the Carriage Holes.

- 1 Attaching Knob
- 2 Carriage Holes
- 3 Pins

Turn the Attaching Knob clockwise.

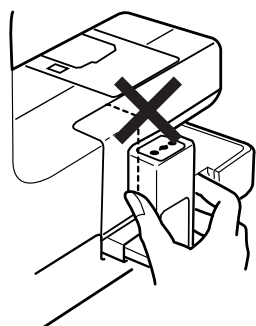
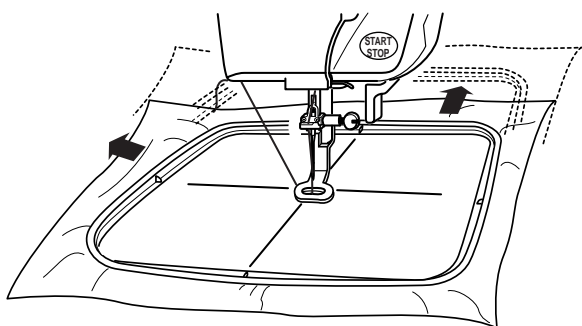

CAUTIONS:

Always provide sufficient clearance for the embroidery carriage behind your machine before starting embroidery.

Never try to move the carriage by hand or touch the carriage while it is moving.

Make sure to return the carriage to the home position before turning the power off.

Thread Holder

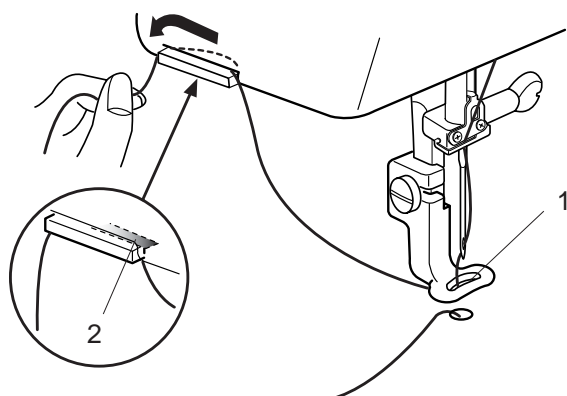

To avoid sewing on the needle thread, place the thread end on the Thread Holder.

Pass the needle thread through the Hole in the Embroidery Foot and draw it up to the thread holder. Hang the thread on the thread holder from the front to back.

- 1 Hole in the Embroidery Foot
- 2 Thread Holder

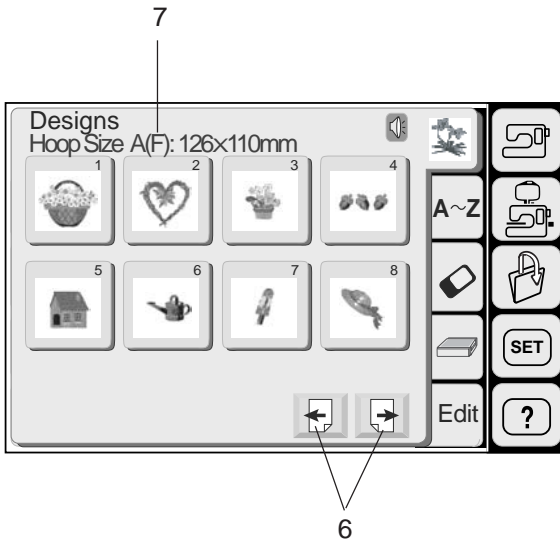
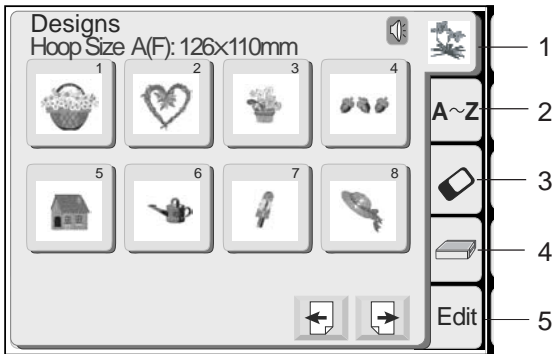
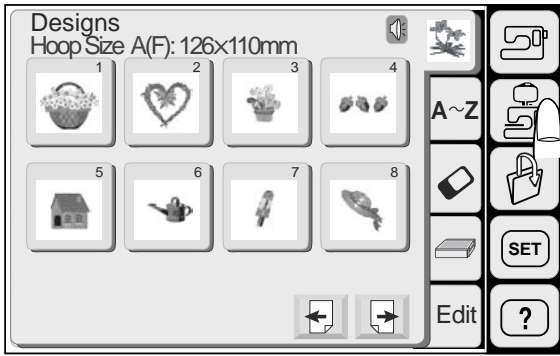

Mode Selection

Press the Embroidery Mode Key to enter the Embroidery Mode. The following 5 categories are available in the Embroidery Mode:

1 Built-in Designs

The Visual Touch Screen shows the Built-in Design window when the Embroidery Mode Key is pressed. The Memory Craft 9500 provides 91 ready to sew built-in embroidery designs.

2 Monogramming

Press the Monogramming Key to open the Monogramming window. You can sew monograms in five different styles, Gothic, Script, Cheltenham, 3-letters and 2-letters.

3 PC Card Designs

Press the PC Card Key to sew the designs from PC Design Cards (optional items).

4 Card Reader 10000

The Memory Craft 9500 can read and sew embroidery designs available from the Memory Cards for Memory Craft 9000/5700 via the Card Reader 10000 (optional accessory).



NOTE:

To connect the Card Reader 10000 and the Memory Craft 9500, a special cable (optional accessory) is necessary.

5 Editing

In the Editing window, you can modify and combine patterns to create original designs.

6 Page keys

Press the Next page  key to view the next page. Press the Previous Page  key to view the previous page.

7 Hoop size

The appropriate hoop and its size for the selected pattern are displayed on the screen.

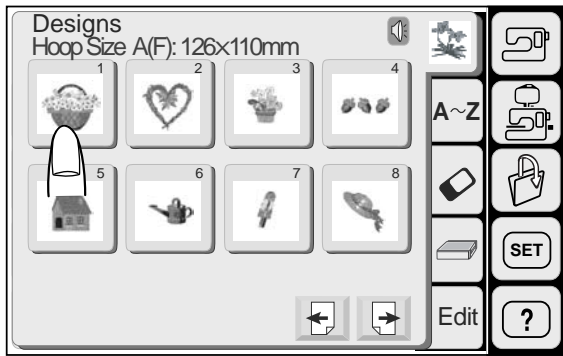

Built-in Designs

Press the Built-in Design key.

Press the pattern selection key to select the desired pattern.

The embroidery screen will appear.

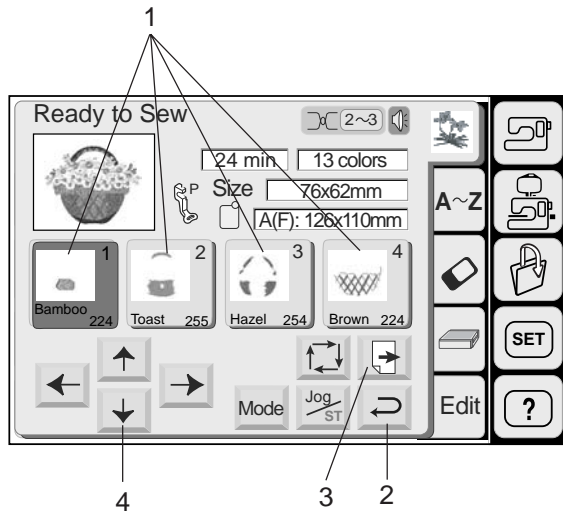

1 Color/Part key

The thread color and the sewing order of each section of embroidery is indicated on the key.

The machine will automatically stop sewing when one part of the embroidery design is finished.

Change the thread and start sewing again. The color of the key will darken after you finish sewing that part of the embroidery design.

Sewing the specific color/part by skipping

You can sew only the specific part of the design by skipping the parts before it.

Press the color/part key previous to the part you wish to start sewing, and the skipped parts will darken.

2 Return key

Press this key to return to the pattern selection window.

3 Next page Key

The next page key will be displayed when there are more design parts to be displayed. Press it to view the other embroidery design parts.

4 Jog Keys

Adjust the hoop position with the jog keys so that the needle drop position comes right above the center of the reference lines on the fabric.

- 5 Needle drop position
- 6 Centerlines

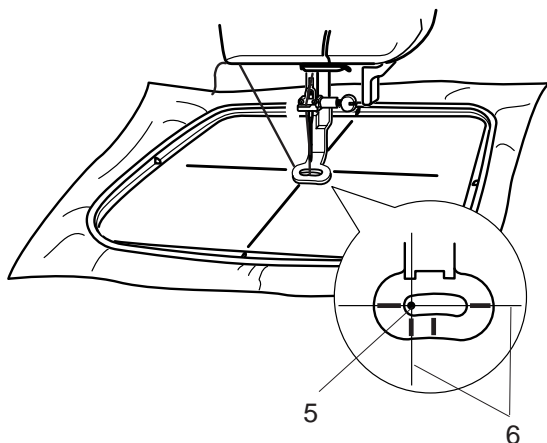

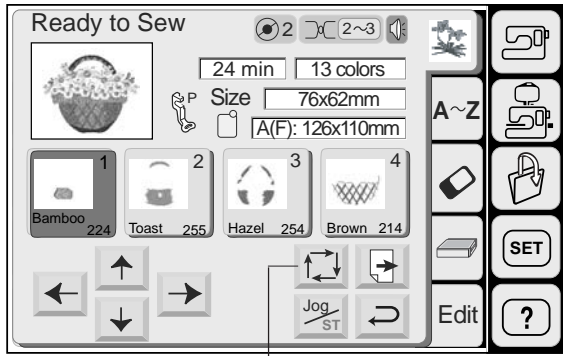

1

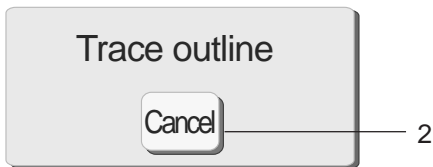
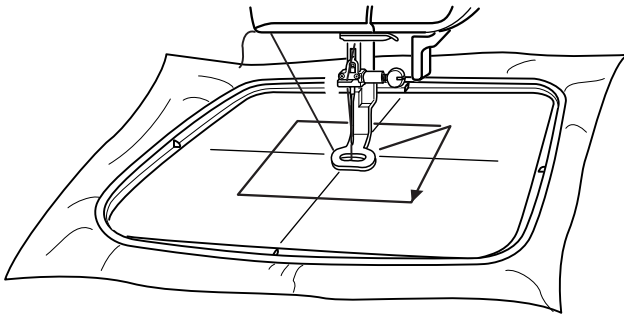

2

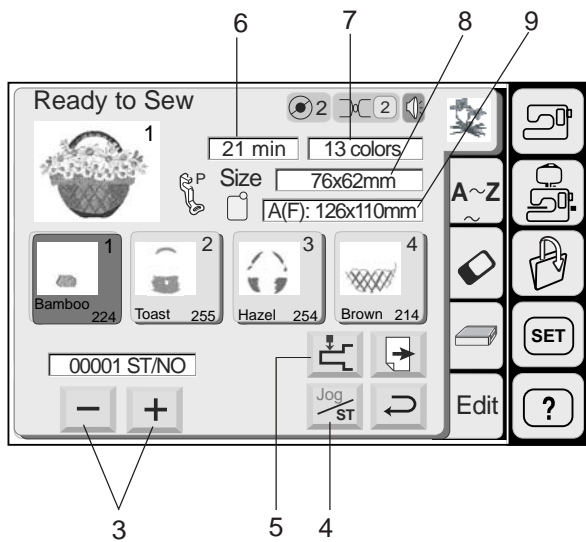

3

5

4

1 Trace key

You can check the size of the sewing area by pressing this key. The carriage traces the outline of the selected embroidery pattern without stitching. The carriage will return to the starting position after tracing.

2 Cancel key

Press this key to cancel the tracing and return to the previous screen.

3 Stitch Back/Forward keys

When embroidery sewing has started, the screen will indicate the current stitch counts. The Jog keys will disappear and the stitch back/forward keys will be shown on the screen. You can use these keys to move the embroidery hoop to where the thread has broken or run out.

Press the **-** key to move the hoop back to a previous sewing point. The hoop will move backward 10 stitches each time this key is pressed.

Press the **+** key to move the hoop ahead. The hoop will move forward 10 stitches each time this key is pressed.

4 Jog/ST key

Press this key to switch the jog keys to the stitch back forward keys or vice versa.

5 Return Carriage Key

Press the return carriage key to bring the carriage back to its stored position after finishing embroidery.

Screen Information

Beside the design image, the approximate sewing time in minutes, number of colors, design size and the hoop that should be used for the selected design are shown.

- 6 Sewing time in minutes
- 7 Number of colors
- 8 Design size
- 9 Hoop

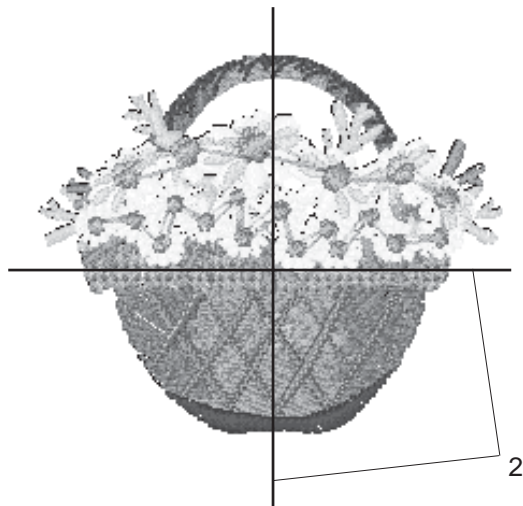
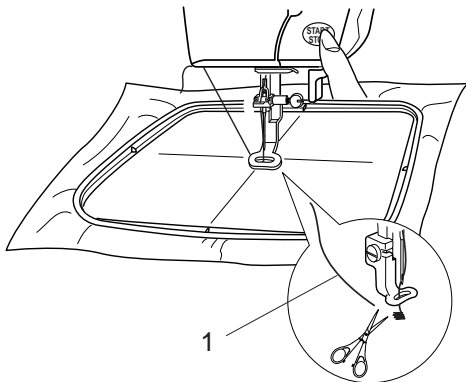
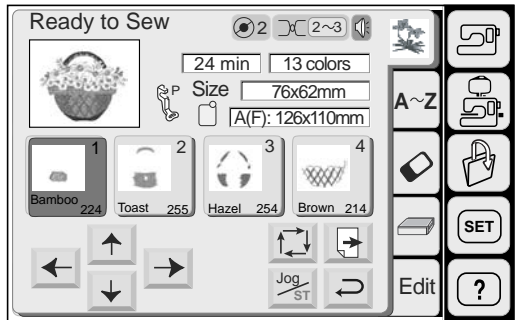
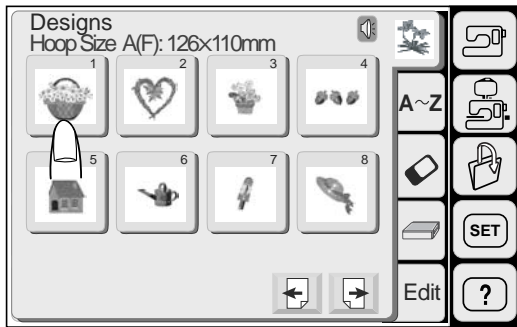

Starting to Sew Embroidery

Press the Pattern Selection key to select the desired pattern.

Lower the presser foot.
Press the Start/Stop button and sew 5 to 6 stitches.

Press the Start/Stop button again to stop the machine.

Raise the presser foot, cut off the Loose Thread close to the beginning of the starting point and lower the presser foot.

1 Loose Thread

Press the Start/Stop button to start sewing again.
The machine will stop automatically when the first color section is finished.
Change the thread and sew the next part.

Sewing results

The embroidery pattern is sewn against the centerlines on the fabric as shown.

2 Centerlines on the Fabric

NOTES:

The embroidery stitch pattern position against the centerlines is indicated on the template sheets.
For embroidery sewing with the PC cards, use the included template sheets to set the correct sewing position.



Monogram Embroidery

Press the Monogram key to open the monogram window.

1 Monogram Key

In the monogram selection window, you can program words by pressing the alphabet keys directly. After you press an alphabet key, the letter is memorized and the cursor is moved to the right.

2 Cursor

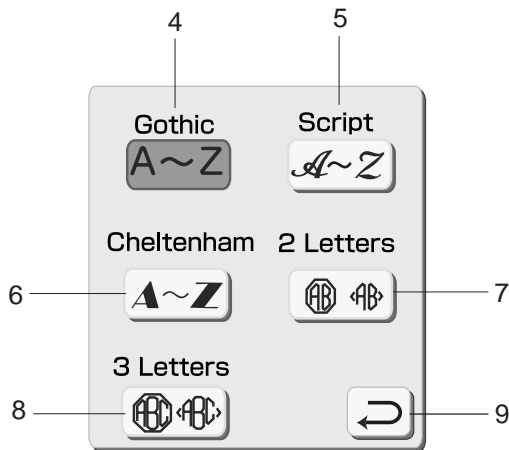

Font Selection

You can change the type of font for monogramming by pressing the Font key. The font selection window will open.

3 Font key

To select the desired font, press one of the following options.

- 4 Gothic Font
- 5 Script Font
- 6 Cheltenham Font
- 7 2-Letters
- 8 3-Letters

When you press the Return key, the screen will return to the previous display.

9 Return key

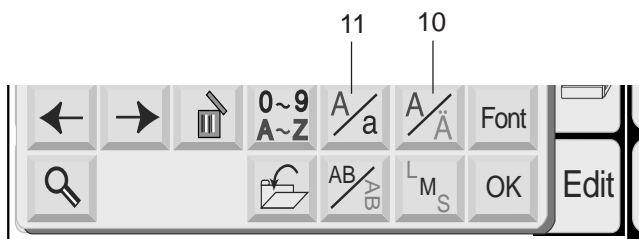

European accented letter key

You can select European accented letters, such as the diaeresis by pressing this key.

10 European Accented Letter key

Upper/Lower case key

You can select upper or lower case letters by pressing this key.

11 Upper/Lower Case key

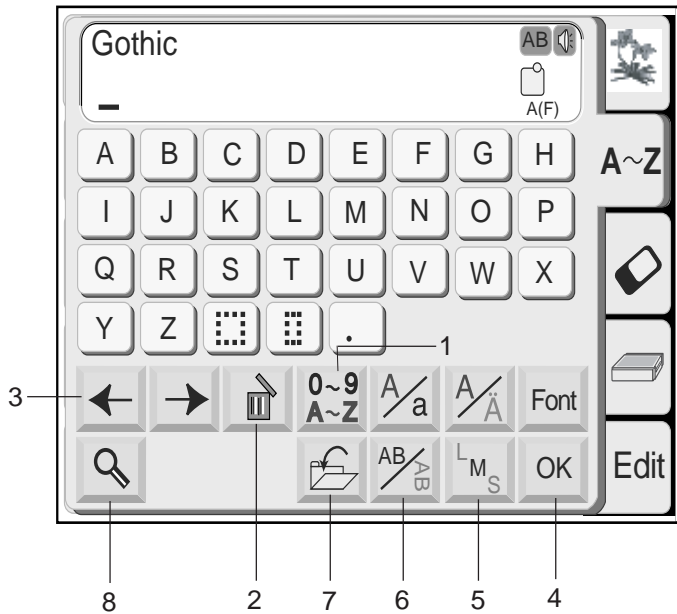

1 Letter/number key

When you press this key, the number and symbols will appear. To select the number or symbol, press the corresponding key. Press this key again to return to the letter selection window.

2 Delete key

Characters can be deleted when they are underlined by the cursor. Move the cursor under the letter, number or symbol you want to delete and press the delete key.

3 Cursor keys

Slide the cursor to the right or left by pressing either of the arrow keys. To add letters/numbers/symbols (character) into a monogram, move the cursor under a character. Press the new character key and it will be inserted before the underlined character.

4 OK key

Pressing the OK key confirms your entry. After the key is pressed the screen will change to the Embroidery screen.

5 Letter Size key

You can choose three different sizes of letters: large, medium and small. Set the size of monogram before selecting the letter.

6 Horizontal/Vertical key

You can choose the direction of the embroidery either horizontal or vertical.

7 File Save key

You can save the monogram by pressing this key. The File Save window will appear.

8 Magnifier key

Pressing this key will enlarge the letter keys to make entry easier.

9 Return key

Press this key to return to the previous screen.

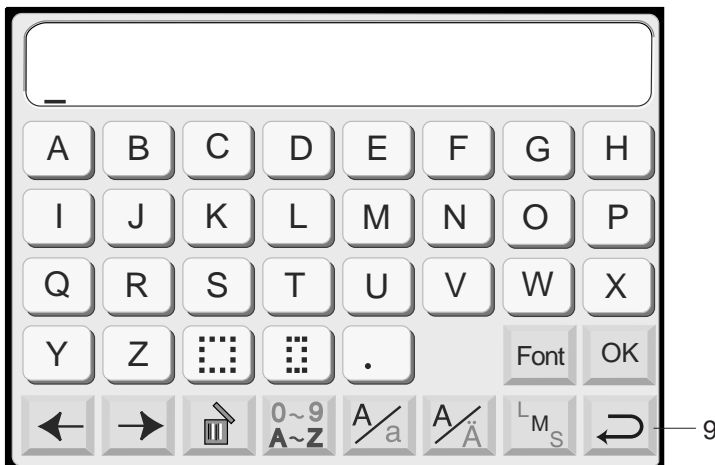

Monogram in Gothic style

Press the Font key and select Gothic style letters.
Select "B".

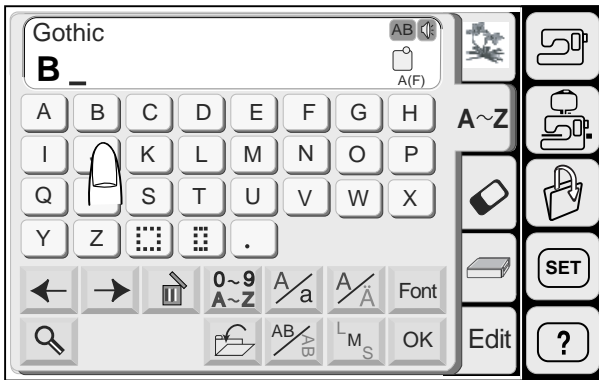

Press the Upper/Lower Case key to select lowercase letters.

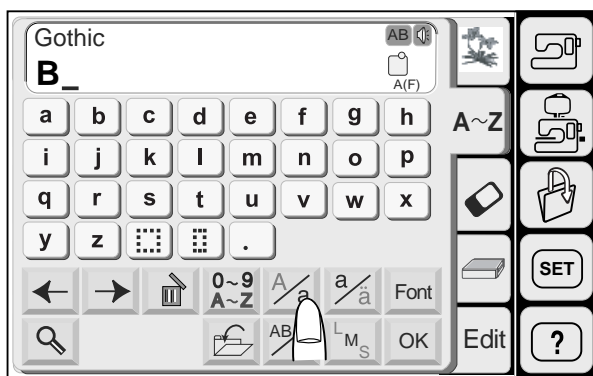

Select "e", "a" and "r".

Press the OK key.

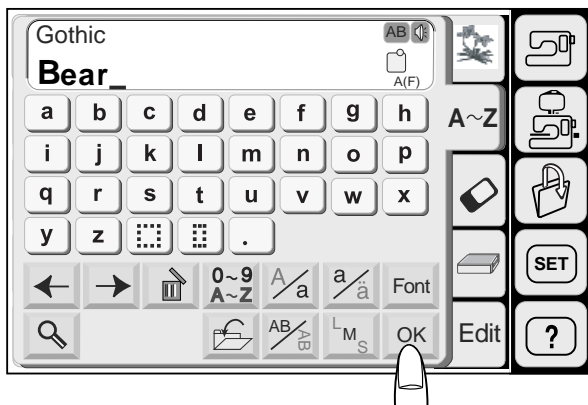

The display will change to the embroidery screen.

You can sew a multi-colored monogram by changing the thread color of each letter if you press the Color Change key before sewing.

The machine will stop automatically when each letter has been sewn. Change the thread and start sewing again.

1 Color Change key



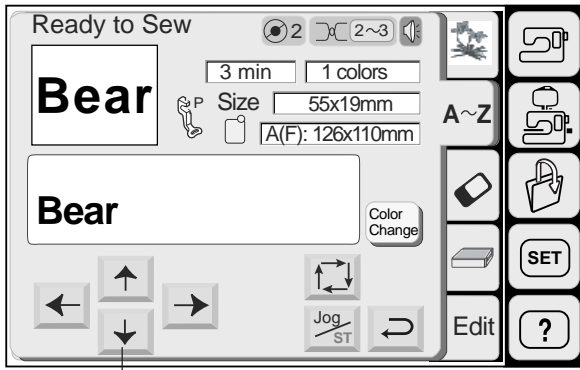

1

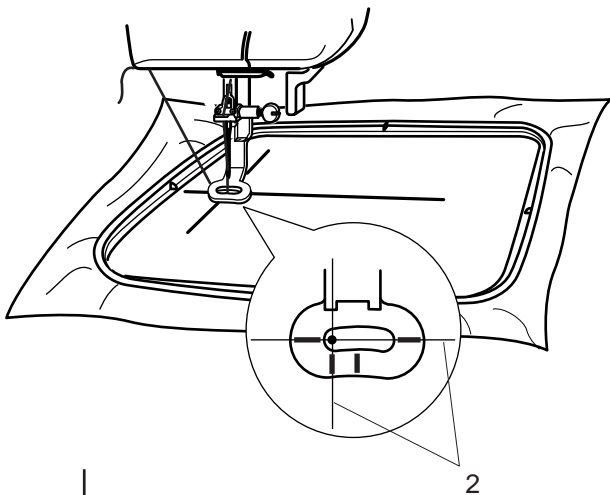

2

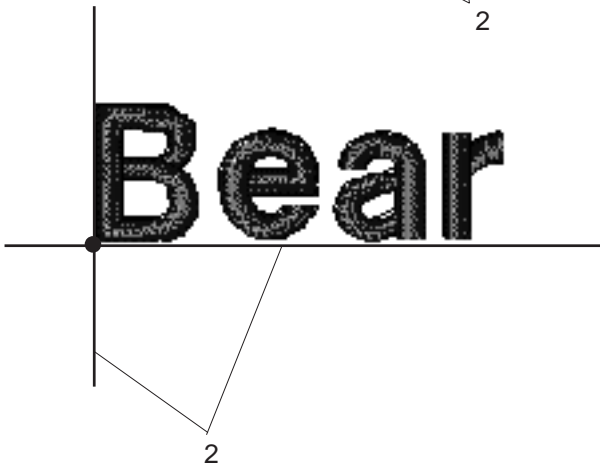

2

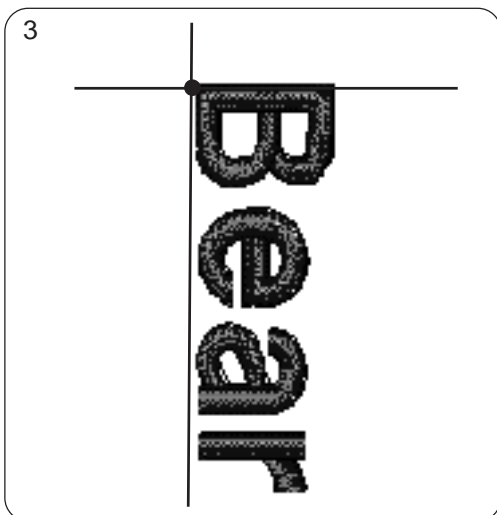

3

Use the Jog keys to adjust the position of the hoop to match the centerlines.

- 1 Jog Keys
- 2 Centerlines

Lower the presser foot.

Press the Start/stop button and sew 5 to 6 stitches.

Press the Start/stop button again to stop the machine.

Raise the presser foot, cut off the loose thread close to the beginning of the starting point and lower the presser foot.

Press the Start/stop button to start sewing again.

The machine will stop automatically when the monogram is completed.

You can sew the monogram vertically if you select a vertical orientation after entering the characters.

- 3 Monogram in vertical orientation

2- Letters monogram

Example: 2-Letters with a crest

Press the Font key.
Select 2-Letters.

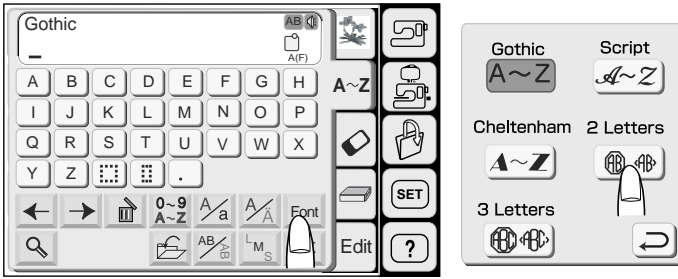

Select the Frame.

Select the letter "A".

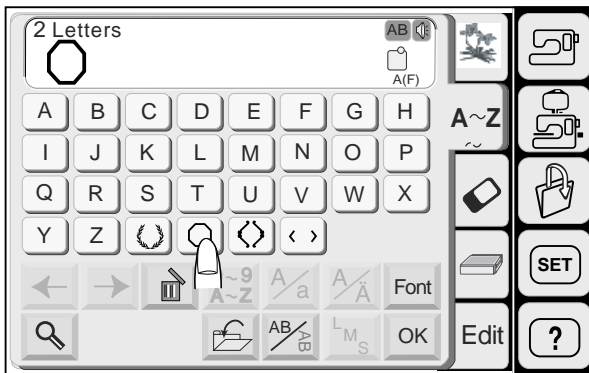

Select the letter "B".

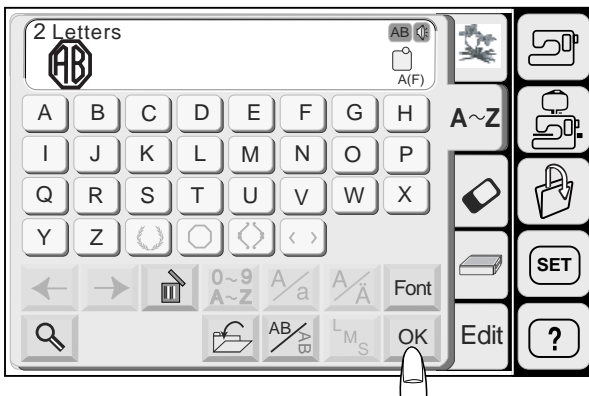

Press the OK key and the screen will change to the embroidery screen.

Press the Start/stop button to start sewing and the machine will stop sewing automatically.

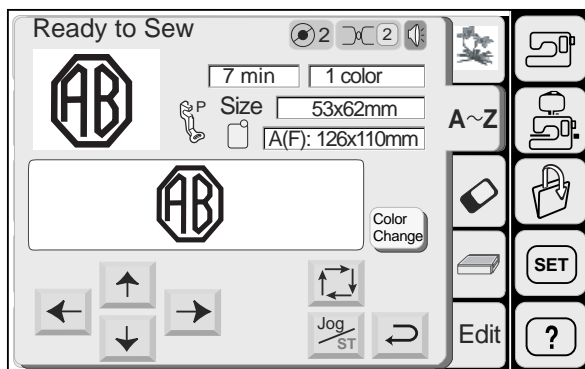

NOTES:

The 3-Letters monogram will be sewn in the same way as the 2-Letters monogram.

The starting position for the 2-letters and 3-letters is in the center of the hoop.



Correcting a monogram

Deleting a letter

Example: To delete "E" from "BEAT"

Press the Cursor  key to shift the cursor under the letter to delete.

Press the Delete  key.

The letter "E" will be deleted.

Inserting a letter

Example: To insert "E" to "BAT"

Press the Cursor  key to shift the cursor under the letter before where you wish to insert a letter.

Select the letter "E".

The letter "E" will be inserted between "B" and "A".

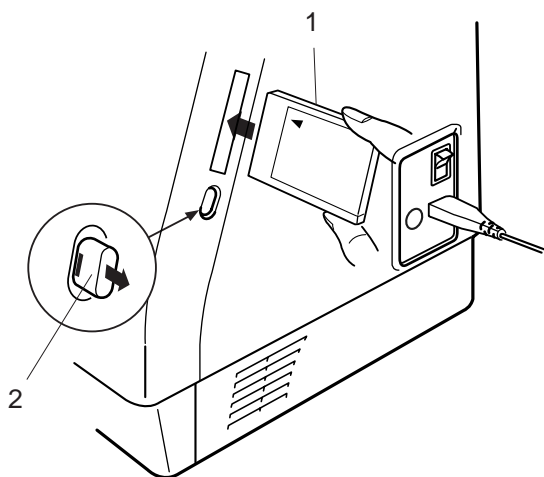

PC Card Designs

Inserting and ejecting a PC Card

Insert a PC card into the slot with the front side facing to you.
Push the card until it clicks, then the eject button pops out.

- 1 PC Card
- 2 Eject Button

NOTE:

When the card is properly set, the red bar on the eject button will show.

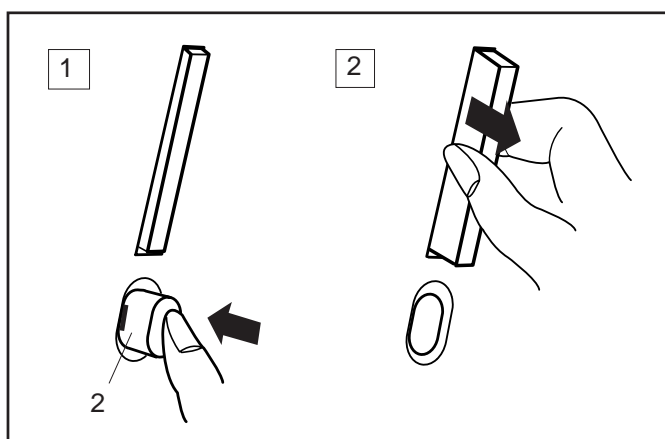

Ejecting the PC card

Press the Eject Button to eject the PC card.
Take out the PC card from the machine.

NOTE:

When the power is turned on with a PC card inserted in the machine, it will take sometime to get the machine booted up.

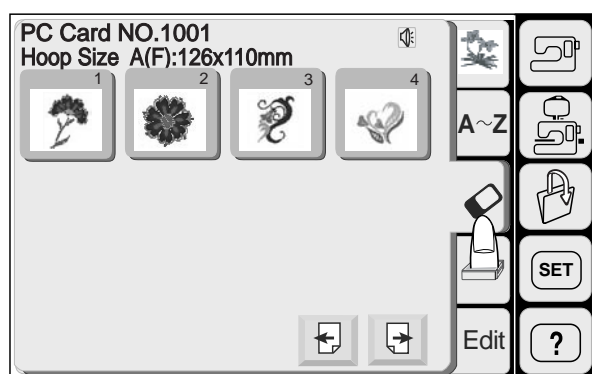



Selecting the PC card designs

Press the PC card key. The designs contained in the card are displayed on the pattern selection keys.

Press the pattern selection key to select the design you wish to sew.
The selected design and its color parts will be shown in their sewing order.

CAUTION:

Do not turn the power off or eject the card while the warning sign   or hourglass is displayed.

Card Reader 10000 (optional item)

You can download designs from the Memory Cards for Model MC9000 via the Card Reader 10000.

Connecting Card Reader 10000

Insert the round connector of the special RS-2332C cable into the machine.

Insert the 2 plugs into the Card Reader 10000.

- 1 RS-232C Cable
- 2 Card Reader 10000

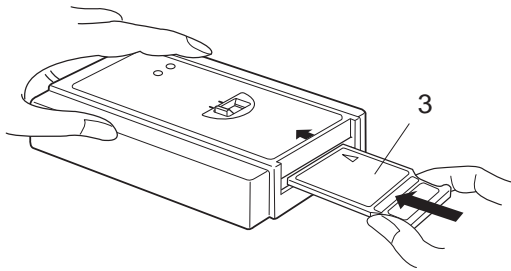
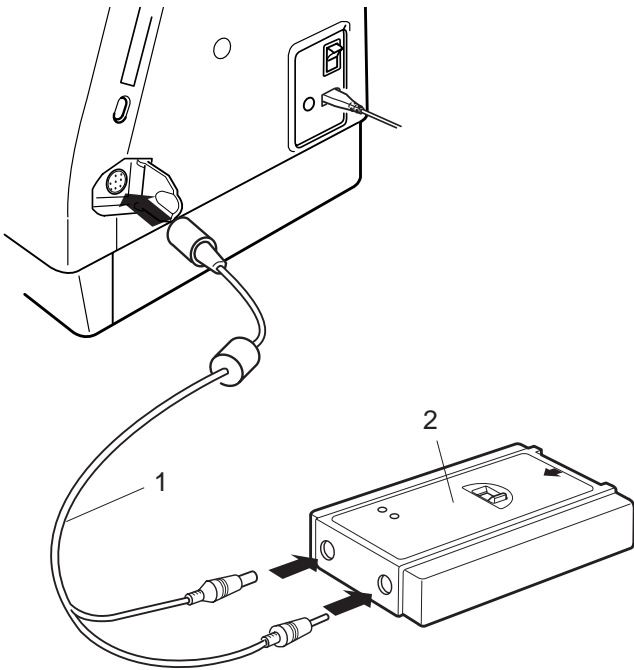

Insert the Memory card into the Card Reader 10000. Push the card until it clicks.

- 3 Memory Card

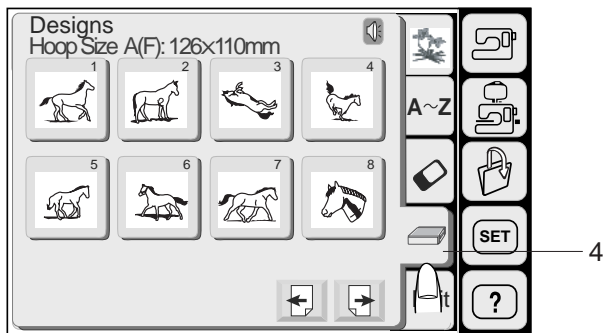

Selecting a pattern

Press the Card Reader Key.

The Pattern Selection Screen will appear.

- 4 Card Reader Key

NOTE:
The key operation is the same as for built-in designs. See pages 80-82.

Editing Mode

The editing function allows you to modify and combine embroidery patterns to create your own original designs.

Editing screen

Press the Edit key to open the editing screen.

- 1 Edit Key

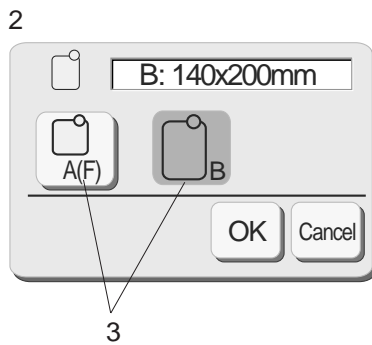
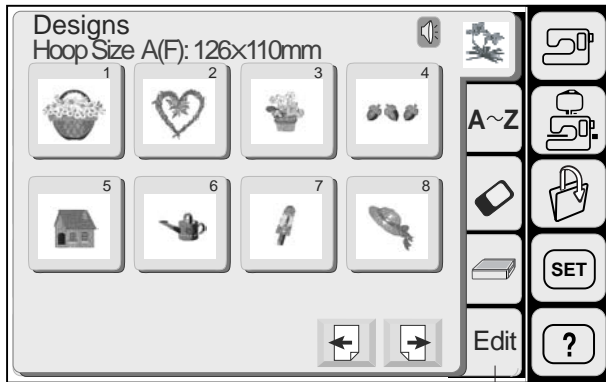

The hoop selection window opens to allow you to select the hoop you wish to use.

You can select one of the following hoops:

Standard Hoop A: 126 mm by 110 mm

Round Hoop F: 126 mm by 110 mm (Optional item)

Large Hoop B: 140 mm by 200 mm

- 2 Hoop Selection Window
- 3 Hoop Selection Keys

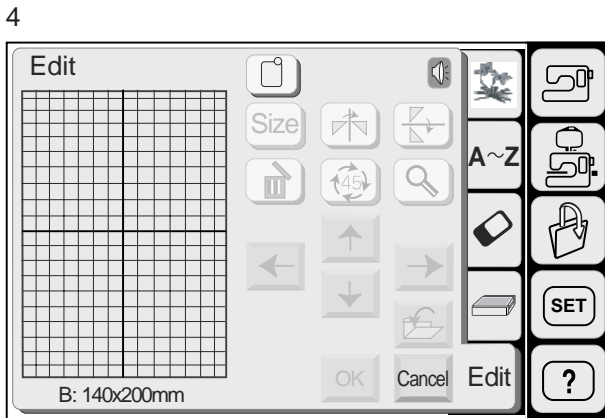

Press the OK key and the editing screen for the selected hoop will open.

- 4 Editing Screen for the Hoop B
- 5 Editing Screen for the Hoop A (F)

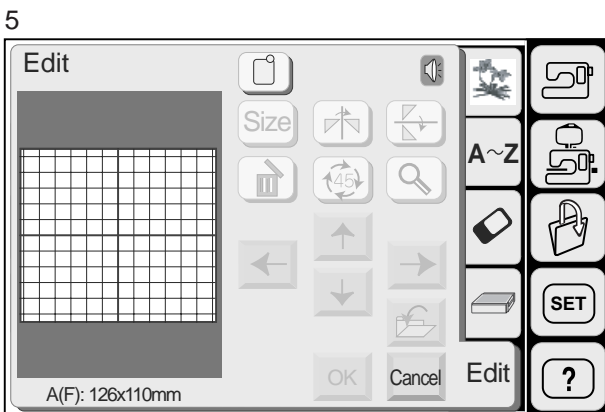

Selecting the pattern to edit

The Patterns from the built-in designs, monograms, PC cards and Memory Cards can be edited.

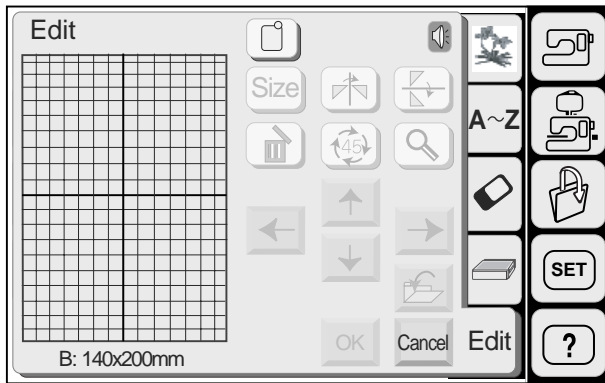

To select the pattern to edit, press the pattern selection key of the desired pattern on the editing screen.

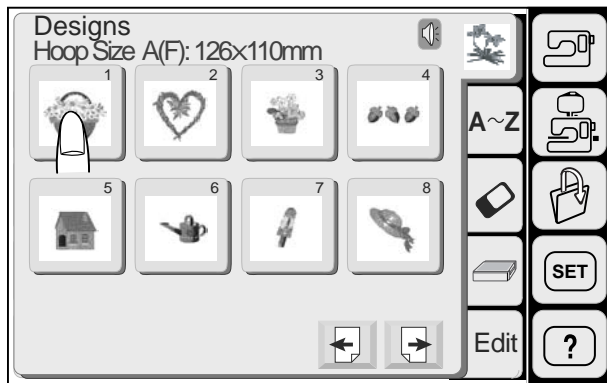

The selected pattern will be framed.

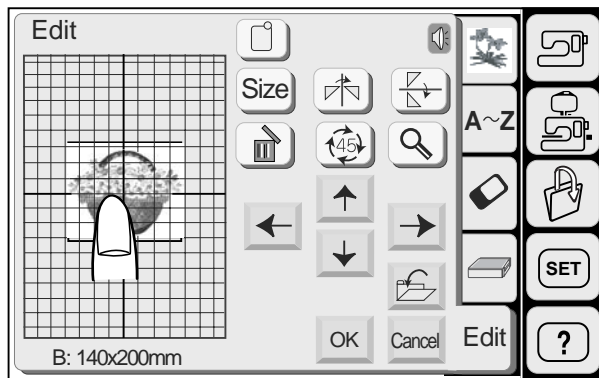

Moving a pattern

To move the embroidery pattern on the editing screen, press and drag the pattern to a desired location with your fingertip.

NOTE:

Do not drag the pattern on the screen with a sharp pointed object.

You can move the selected pattern also by pressing the Layout keys.

Press the Layout Keys to move the pattern to the desired position on the Edit screen.

The carriage will not move when you press the layout keys since the pattern position will move relatively to the hoop, not to the machine.

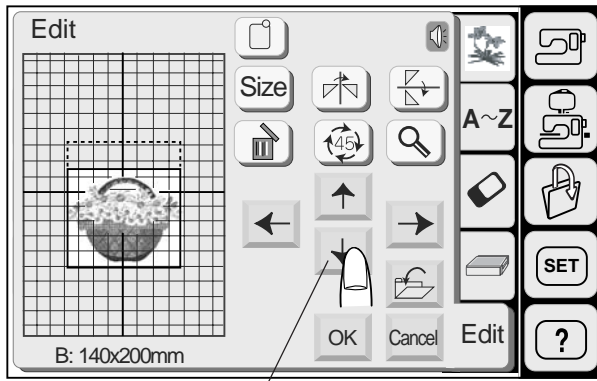

1

1 Layout Key

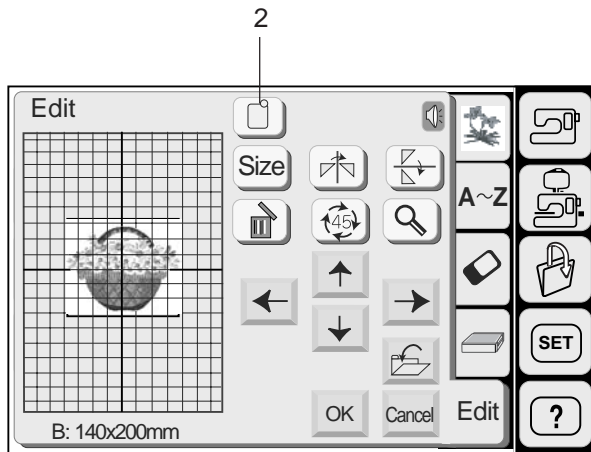

2

Selecting the hoop

In the editing window, you need to select the appropriate size of the embroidery hoop by pressing the hoop selection key.

There are two hoop size selections:

Embroidery Hoop A, 12.6 cm (4 3/8") by 11 cm (4 3/8")

Embroidery Hoop B, 20 cm (8") by 14 cm (5 1/2")

2 Hoop Selection Key

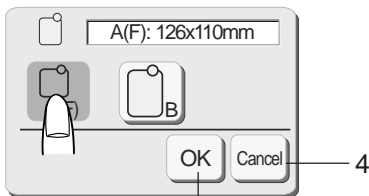

3

Select the desired hoop.

Press the OK key and the Editing window for the selected hoop will appear.

3 OK Key

Press the Cancel key to return to the default setting (Hoop B).

4 Cancel Key

5 Editing Screen for the Hoop A

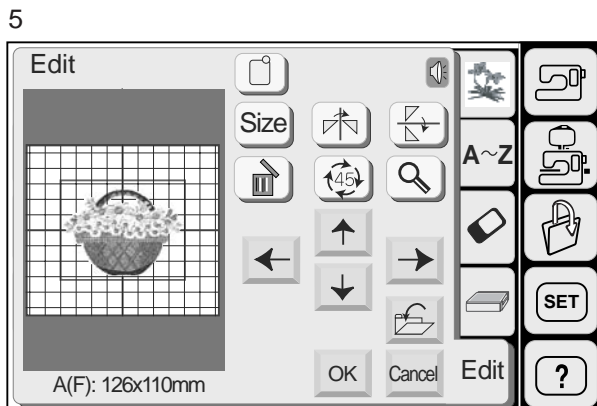

5

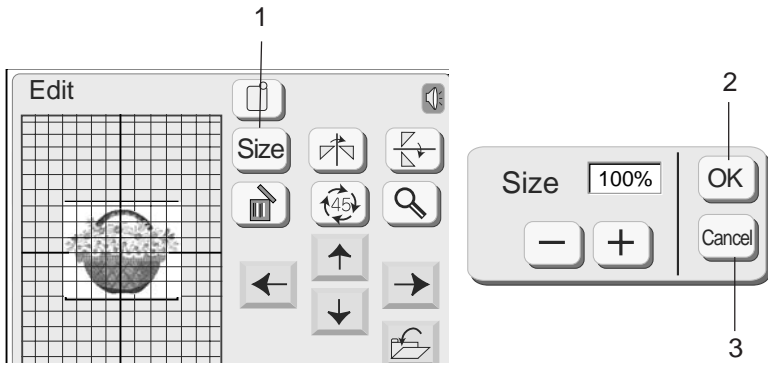

Resizing a pattern

When you press the size key, the size adjusting window will appear.

- 1 Size Key

You can change the size of embroidery patterns from 90% to 120% of the original pattern size. The size will change 10% each time you press the plus or minus key.

Press the **+** key to enlarge the size of the pattern. Press the **-** key to reduce the size of the pattern.

When you press the OK **OK** key, the embroidery pattern in the new size will appear on the Edit screen.

When you press the Cancel **Cancel** key, the embroidery pattern size will not change and the Edit screen will reappear.

- 2 OK Key
- 3 Cancel Key

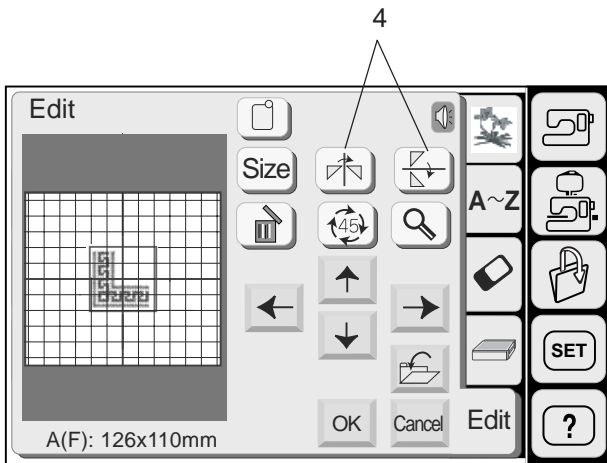

Flipping a pattern

When you press the Mirror Image keys, you may embroider a mirror image of the pattern.

- 4 Mirror Image Keys

Press the **↔** key to flip the pattern horizontally.

Press the **↕** key to flip the pattern vertically.

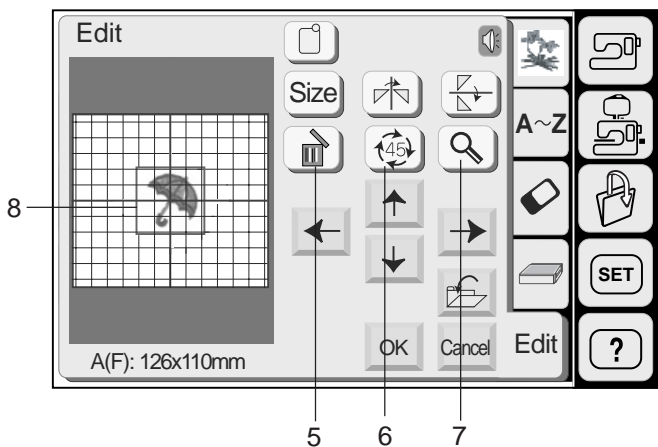

Deleting a pattern

Press the Delete key to delete the selected pattern.

- 5 Delete Key

Rotating the pattern

Press the Rotate key to rotate the selected pattern. The pattern will rotate 45 degrees clockwise when pressing this key.

- 6 Rotate Key

Magnifying a pattern image

Press the Magnifier key to show a magnified image of the selected pattern.

Press the Return **↩** key to return to the previous screen.

- 7 Magnifier Key
- 8 Original image
- 9 Magnified image

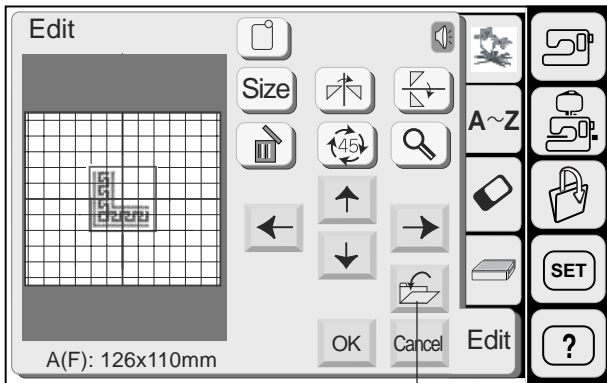

1

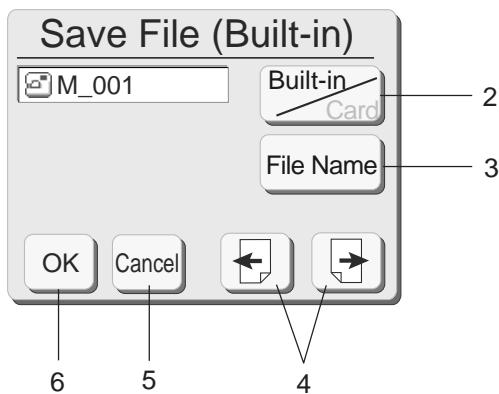

6

5

4

Saving a File

An original design created in the Editing Mode can be saved as a file in the internal memory or an ATA PC card.

Press the Save File key, the Save File window will open.

1 Save file Key

You can select the location to where you want to save the file.

Press the  key, to select the location either in the internal memory of the sewing machine or an ATA PC card.

2 Built-in/Card Key

The file name will be automatically assigned starting from M_001 in order. Press the File Name  key if you wish to assign a new name to the file.

3 File Name key

When you press the   keys, you will be able to see the saved files on the previous and next pages.

4 Page keys



Press the OK  key to save the file and the screen will return to the original screen.

If you do not want to save the file, press the Cancel  key to return to the previous window.

5 Cancel Key

6 OK Key

CAUTION:

Do not turn the power off or eject the card when the warning sign   or hourglass is displayed on the visual touch screen. Otherwise, data stored in the memory may be lost or damaged.



Assigning the a name

You can assign a file name in the file name window.

Press the File Name key to open the file name window.

The character keys are displayed in the window. Press the character keys to enter the desired name. Only 8 characters can be entered.

Press the Back Space key to delete the last character.

Press the Cancel key and the screen will return to the save file window.

Press the OK key to save the file under the new name.

The file will be saved with the new name.

- 7 B. S key
- 8 Cancel key
- 9 OK key

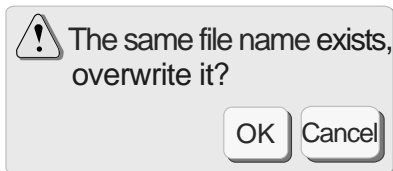
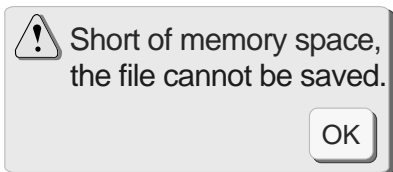

NOTES:

When the memory is full, a warning message will appear.

Press the key and go to the open file window then delete the file that you do not need.

When you save a file under the same name, a warning message will appear.

Press the OK key to overwrite the existing file.

Press the Cancel key if you do not wish to overwrite it. You may need to change the file name and save the file under the different name.

Combining a built-in design and monogram

Example: To combine built-in design 41 and the word “Bear”

Select the pattern 41 from the built-in designs.

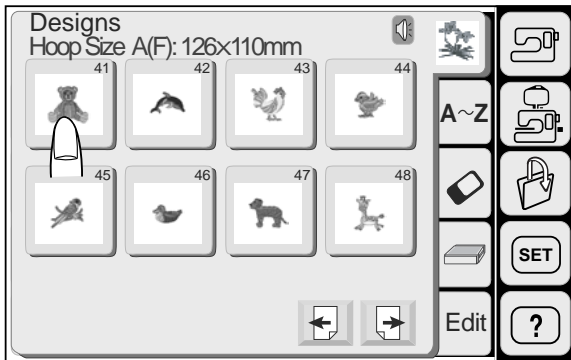

Press the Edit key.
The pattern image will appear in the editing window.

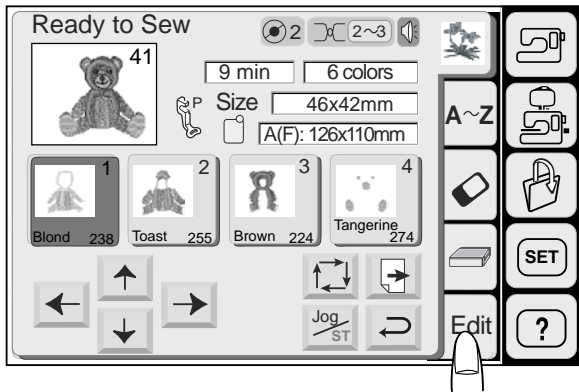

Press the Monogram key.

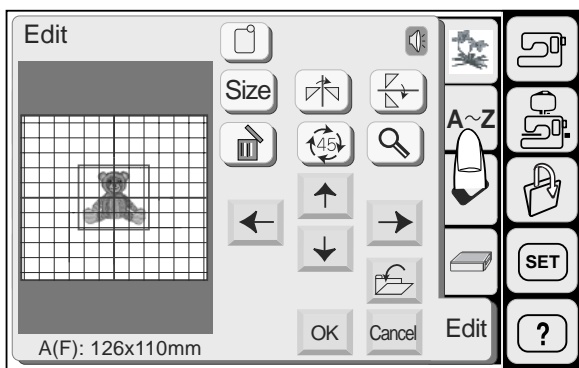

Select “B” (Upper case letter in Gothic style).

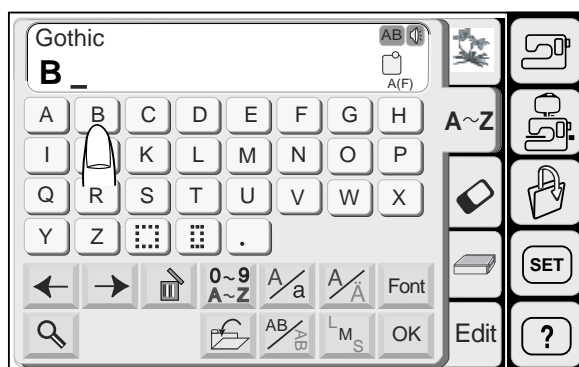

Press the Letter Case key to select lower case letters.

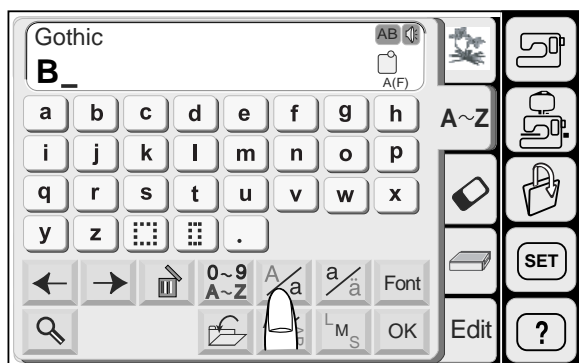



Select “e”, “a” and “r”.

Press the OK key.
The word “Bear” will appear in the editing window.

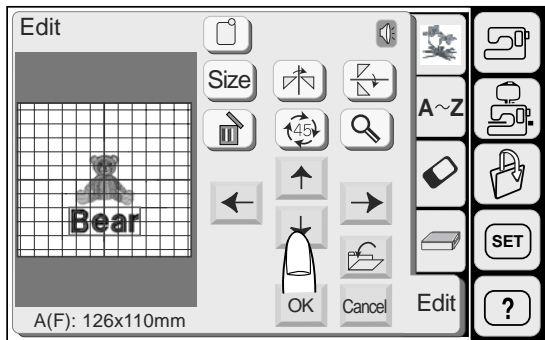

Move the word under the pattern by dragging it or with the layout keys.

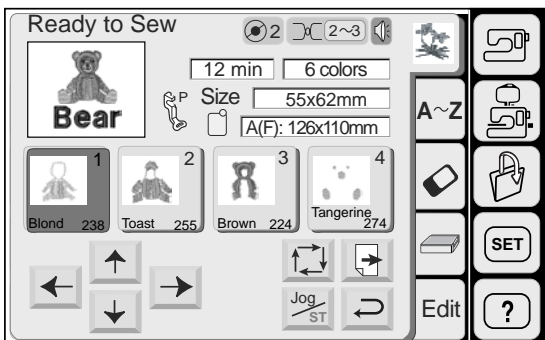

Press the OK key and the display will change to the embroidery screen.
Start the machine to sew the combined design.



1 Stitched Result of the Combined Design

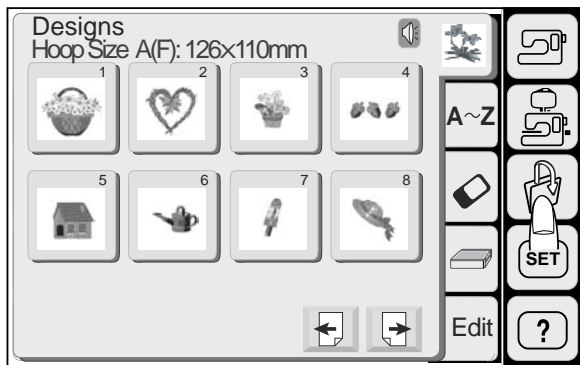

Opening a Saved File

You can open a file to sew embroidery patterns that you have saved.

When you press the open file key, the open file window will appear.

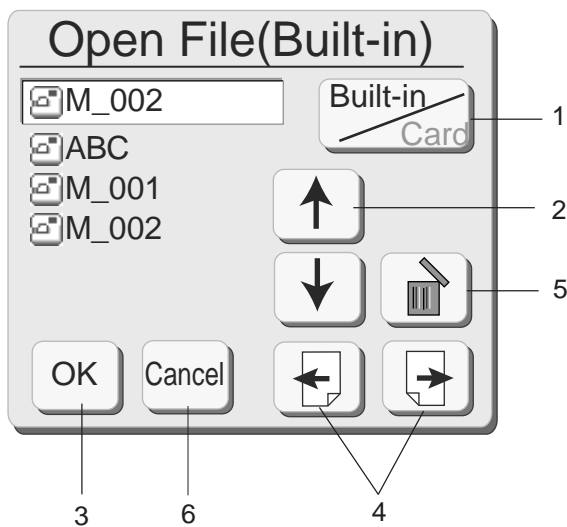

Press the key to select the location of the file, either in the internal memory of the machine or in an ATA PC card.

Press the keys to select the desired file to open.

Press the OK key to open the selected file.

The pattern combination of the file will be displayed on the screen.

- 1 Built-in/Card Key
- 2 Arrow Keys
- 3 OK Key

Pressing the keys will show the saved files in the next or previous page.

- 4 Page Keys

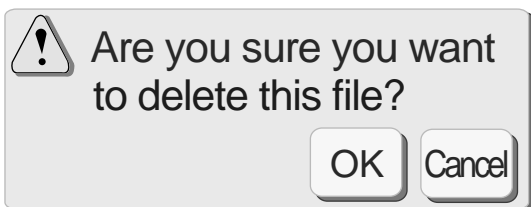

Deleting a saved file

When you need to delete the saved file, select the file to delete then press the Delete key.

- 5 Delete Key

The confirmation window will appear.

Press the OK key if you are sure you want to delete it.

When you press the Cancel key, the file will not be deleted.

- 6 Cancel Key

On-screen Help

You can view on-screen help for the basic operations of the machine.

Press the Help key.
The help index window will appear.

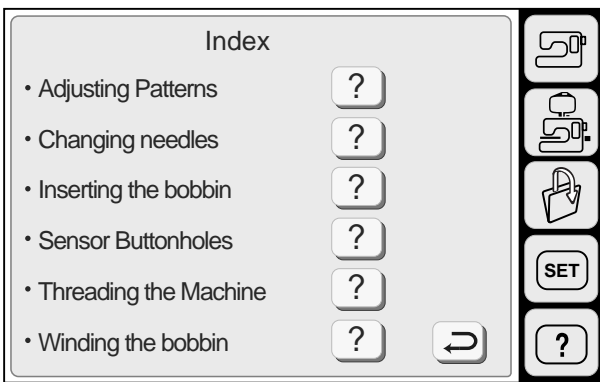
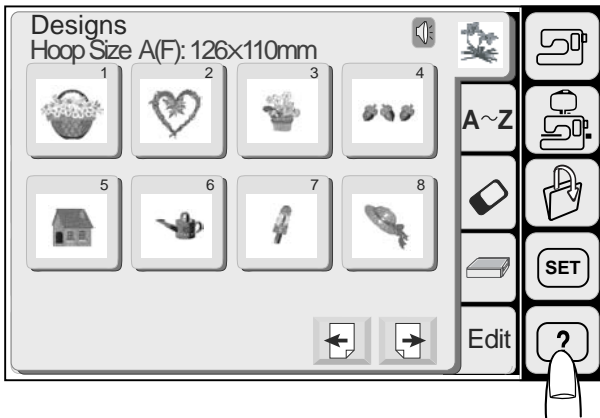

Select a help topic by pressing one of the **[?]** keys.

The illustrated help of the selected topic will be displayed on the screen.

NOTE:
Press the Return **[↩]** key to go back to the previous screen.

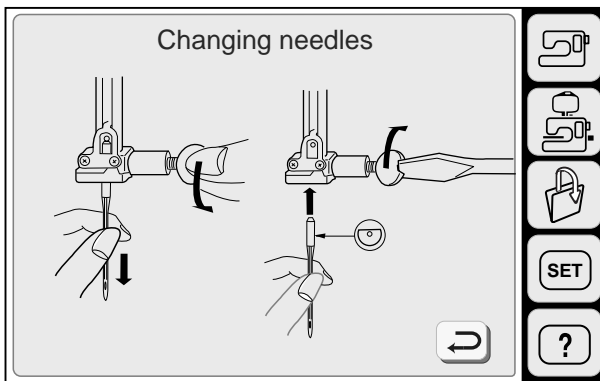

CARE AND MAINTENANCE

WARNING:

Turn the power switch off and unplug the machine before cleaning.

NOTE:

Do not dismantle the machine in any way other than what is explained on this page.

Cleaning the Hook Race and Feed Dog

Remove the Hook Cover Plate by sliding the hook cover plate release button to the right. Take out the bobbin. Remove dust and lint with a lint brush. (You may also use a vacuum cleaner.)

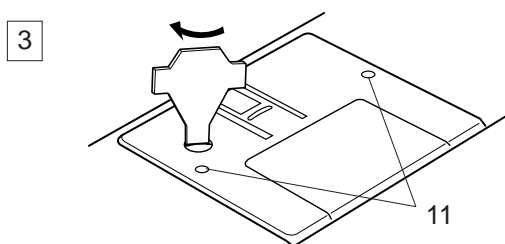
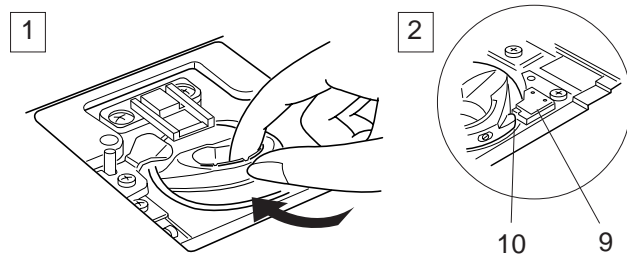
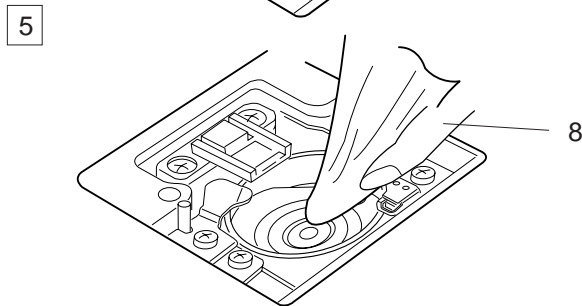
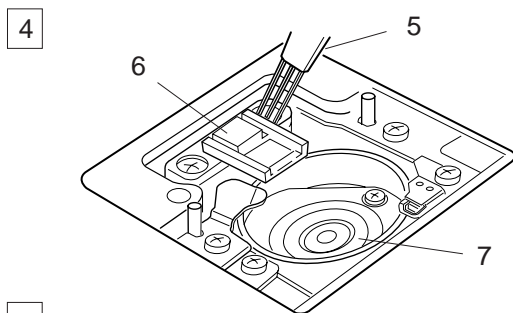
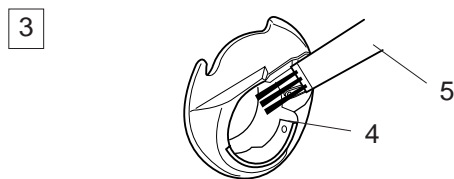
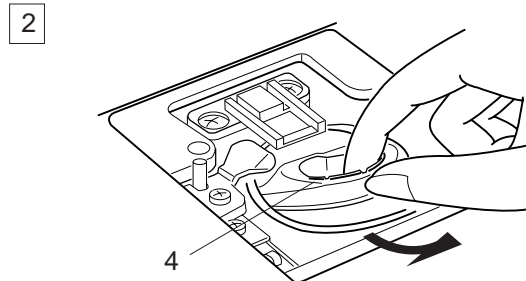
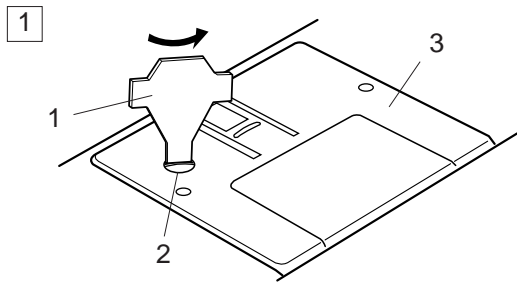

1 Remove the Set Screw on the needle plate with the screwdriver supplied with the machine. Remove the Needle Plate.

2 Take out the bobbin. Lift up the Bobbin Holder and remove it.

3 Clean the Bobbin Holder with a Lint Brush.

4 Clean the Feed Dog and Hook Race with the Lint Brush.

5 Clean the Hook Race with a dry cloth. (You may also use a vacuum cleaner.)

- 1 Screwdriver
- 2 Setscrew
- 3 Needle Plate
- 4 Bobbin Holder
- 5 Lint Brush
- 6 Feed Dog
- 7 Hook Race
- 8 Soft Dry Cloth

Assemble the hook race

1 Insert the Bobbin Holder.

2 The Knob of the bobbin holder should fit next to the Stopper in the hook race.

3 Reattach the needle plate, aligning the Needle Plate Guide Pins with the Guide Holes on the needle plate and tighten the screw.

- 9 Stopper
- 10 Knob
- 11 Guide Holes

NOTE:

After cleaning the machine, make sure the needle and presser foot are attached.

Replacing the Light Bulb

WARNING:

Turn the power off before replacing the light bulb. The bulb could be HOT, wait until it has cooled down before touching it.

To remove:

Remove the cap and setscrew. Remove the faceplate.

- 1 Cap
- 2 Setscrew
- 3 Faceplate

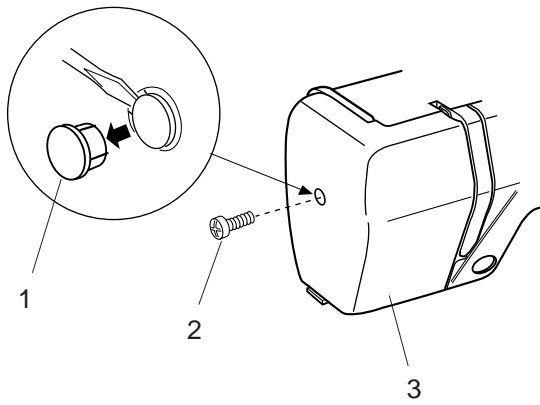

Pull out the bulb from the socket.

- 4 Lamp Socket
- 5 Light bulb

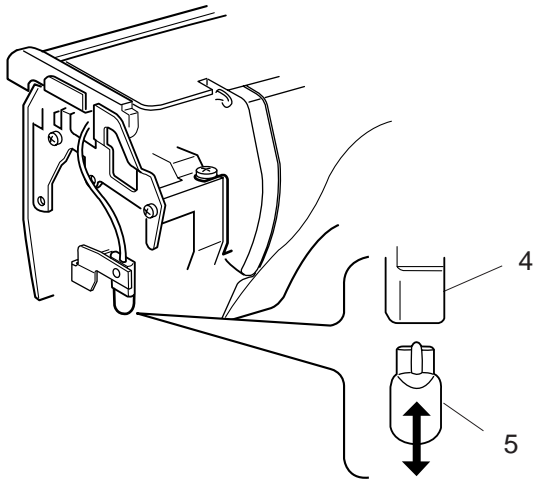

To replace:

Insert the bulb into the opening of the socket. Attach the faceplate with the setscrew, and attach the cap.

Troubleshooting

Problem	Cause	Reference
The machine is noisy.	<ol style="list-style-type: none"> 1. Threads have been caught in the hook mechanism. 2. The feed dog is packed with lint. 	<p>See page 101.</p> <p>See page 101.</p>
The needle thread breaks.	<ol style="list-style-type: none"> 1. The needle thread is not threaded properly. 2. The needle thread tension is too tight. 3. The needle is bent or blunt. 4. The needle is inserted incorrectly. 5. The thread is too heavy for the needle. 6. The needle thread has not set in the thread holder when embroidery sewing started. 	<p>See page 15.</p> <p>See page 19.</p> <p>See page 18.</p> <p>See page 18.</p> <p>See page 18.</p> <p>See page 78.</p>
The bobbin thread breaks.	<ol style="list-style-type: none"> 1. The bobbin thread is not threaded properly in the bobbin holder. 2. Lint has collected in the bobbin holder. 3. The bobbin is damaged and doesn't turn smoothly. 	<p>See page 14.</p> <p>See page 101. Replace the bobbin.</p>
The needle breaks.	<ol style="list-style-type: none"> 1. The needle is inserted incorrectly. 2. The needle is bent or blunt. 3. The needle clamp screw is loose. 4. The needle thread tension is too tight. 5. The fabric is not drawn to the rear when sewing is finished. 6. The needle is too fine for the fabric being sewn. 	<p>See page 18.</p> <p>See page 18.</p> <p>See page 18.</p> <p>See page 19.</p> <p>See page 28.</p> <p>See page 18.</p>
Visual Touch Screen is not clear.	<ol style="list-style-type: none"> 1. The contrast of the screen is not adjusted properly. 	<p>See page 22.</p>
PC Card does not work.	<ol style="list-style-type: none"> 1. The PC Card is not inserted correctly. 	<p>See page 89.</p>
Skipped stitches	<ol style="list-style-type: none"> 1. The needle is inserted incorrectly. 2. The needle is bent or blunt. 3. The needle and/or threads are not suitable for the work being sewn. 4. A BLUE TIPPED needle is not being used for sewing stretch, very fine and synthetics. 5. The needle thread is not threaded properly. 6. A defective (rusted, burred needle eye) needle is used. 7. The embroidery hoop is not set properly. 8. The fabric is not pulled tightly enough on the embroidery hoop. 	<p>See page 18.</p> <p>See page 18.</p> <p>See page 18.</p> <p>See page 18.</p> <p>See page 15. Change the needle.</p> <p>See page 78.</p> <p>See page 77.</p>
Seam puckering	<ol style="list-style-type: none"> 1. The needle tension is too tight. 2. The needle thread or the bobbin thread is not threaded correctly. 3. The needle is too heavy for the fabric being sewn. 4. The stitch length is too long for the fabric. 5. The presser foot pressure is not adjusted correctly * When sewing extremely lightweight materials place interfacing underneath the fabric. 6. The fabric is not pulled tightly enough on the embroidery hoop. 	<p>See page 19.</p> <p>See pages 14, 15.</p> <p>See page 18. Make stitches denser See page 20.</p> <p>See page 77.</p>

Problem	Cause	Reference
Slipping fabric	<ol style="list-style-type: none"> 1. The presser foot pressure is not adjusted correctly 2. The correct presser foot is not being used. 	<p>See page 20. See page 11</p>
The cloth is not feeding smoothly.	<ol style="list-style-type: none"> 1. The feed dog is packed with lint. 2. The presser foot pressure is too weak. 3. The stitches are too fine. 4. The fabric is not fed when sewing is starting. 5. The feed dog is lowered. 6. The correct presser foot is not used. 	<p>See page 101. See page 20. Make stitches coarser. See page 27. See page 20. See page 11.</p>
The machine does not run.	<ol style="list-style-type: none"> 1. The machine is not plugged in. 2. A thread is caught in the hook race. 3. The control circuit is not working correctly. 4. The Start/Stop button is used for ordinary sewing with foot control plugged in. 	<p>See page 6. See page 101. Turn the switch off and turn it on again. See page 7.</p>
Strange sounds occur when the machine is switched on.	<ol style="list-style-type: none"> 1. Something is caught between the carriage and the arm. 2. The carriage is touching something around the machine. 	<p>Remove the object. See page 78.</p>
Patterns are distorted.	<ol style="list-style-type: none"> 1. The correct presser foot is not used. 2. The needle thread tension is too light. 3. The stitch length is not suitable for the fabric being sewn. 4. Feed balancing dial is not properly set. 5. Interfacing is not used for sewing stretch and very fine fabrics. 6. The embroidery hoop Attaching Knob is loose. 7. The carriage is bumping into something around the machine. 8. The fabric is not pulled tightly enough on the embroidery hoop. 9. The fabric is caught or pulled for some reason when sewing embroidery. 	<p>See page 11. See page 19. See pages 30, 33. See page 74. Use an interfacing. See page 78. See page 78. See page 77. Stop the machine and free the fabric.</p>
The automatic buttonhole stitches are not balanced.	<ol style="list-style-type: none"> 1. The stitch length is not suitable for the fabric being sewn. 2. The feed balancing dial is not set properly. 3. Interfacing is not used with stretch fabric. 	<p>See pages 30, 33. See page 74. Use an interfacing.</p>
Pattern selection keys do not work.	<ol style="list-style-type: none"> 1. The bobbin winder spindle is in the winding position. 2. The control circuit is not working correctly. 3. The key position is out of alignment. 	<p>See page 13. Turn the switch off and turn it on again. See page 24.</p>

STITCH CHART

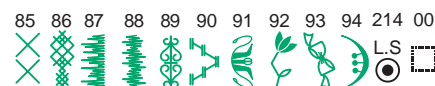
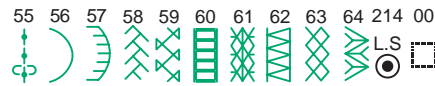
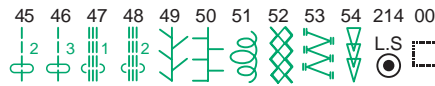
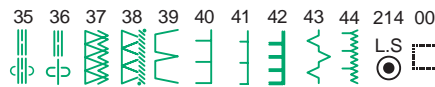
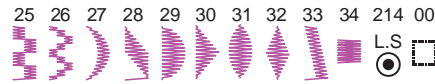
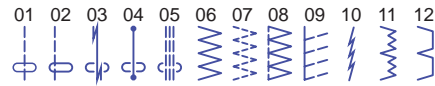

Block

A	B	C	D	E	F	G	H	I	J	K	L	M	N	
O	P	Q	R	S	T	U	V	W	X	Y	Z	□	□	.
a	b	c	d	e	f	g	h	i	j	k	l	m	n	
o	p	q	r	s	t	u	v	w	x	y	z	□	□	.
0	1	2	3	4	5	6	7	8	9	&	_	\$	@	
.	·	,	?	¿	!	¡	‘	’	<	>	-	□	□	
Ä	Â	Á	À	Ã	Å	Ë	Ê	É	È	Ï	Î	Í	Ì	Ñ
Ö	Ô	Ó	Ò	Õ	Ü	Ú	Ù	Û	Æ	Œ	Ç	Ø	ß	
ä	â	á	à	ã	å	ë	ê	é	è	ï	î	í	ì	ñ
ö	ô	ó	ò	õ	ü	ú	ù	û	æ	ij	œ	ç	ø	ß

DESIGN CHART

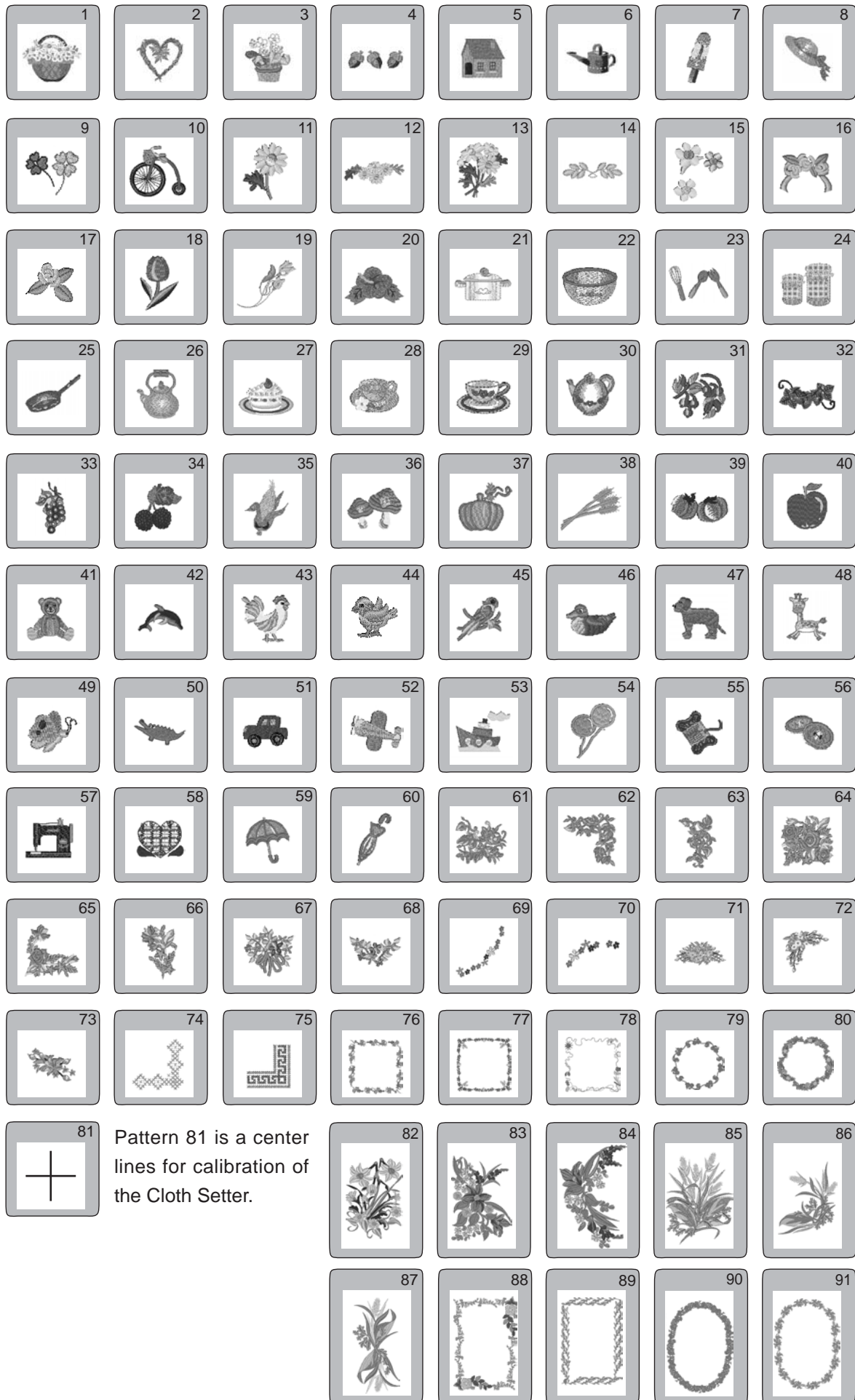

DESIGN CHART

Gothic

A	B	C	D	E	F	G	H	I	J	K	L	M	N	
O	P	Q	R	S	T	U	V	W	X	Y	Z	□	□	.
a	b	c	d	e	f	g	h	i	j	k	l	m	n	
o	p	q	r	s	t	u	v	w	x	y	z	□	□	.
0	1	2	3	4	5	6	7	8	9	&	-	\$	@	
.	•	,	?	¿	!	¡	'	'	<	>	-	□	□	
Ä	Â	Á	À	Ã	Å	Ë	Ê	É	È	Ï	Î	Í	Ì	Ñ
Ö	Ô	Ó	Ò	Õ	Ü	Û	Ú	Ù	Æ	Œ	Ç	Ø	ß	
ä	â	á	à	ã	å	ë	ê	é	è	ï	î	í	ì	ñ
ö	ô	ó	ò	õ	ü	û	ú	ù	æ	ij	œ	ç	ø	ß

Script

A	B	C	D	E	F	G	H	I	J	K	L	M	N	
O	P	Q	R	S	T	U	V	W	X	Y	Z	□	□	.
a	b	c	d	e	f	g	h	i	j	k	l	m	n	
o	p	q	r	s	t	u	v	w	x	y	z	□	□	.
0	1	2	3	4	5	6	7	8	9	&	-	\$	@	
.	•	,	?	¿	!	¡	'	'	<	>	-	□	□	
Ä	Â	Á	À	Ã	Å	Ë	Ê	É	È	Ï	Î	Í	Ì	Ñ
Ö	Ô	Ó	Ò	Õ	Ü	Û	Ú	Ù	Æ	Œ	Ç	Ø	ß	
ä	â	á	à	ã	å	ë	ê	é	è	ï	î	í	ì	ñ
ö	ô	ó	ò	õ	ü	û	ú	ù	æ	ij	œ	ç	ø	ß

Cheltenham

A	B	C	D	E	F	G	H	I	J	K	L	M	N	
O	P	Q	R	S	T	U	V	W	X	Y	Z	□	□	.
a	b	c	d	e	f	g	h	i	j	k	l	m	n	
o	p	q	r	s	t	u	v	w	x	y	z	□	□	.
0	1	2	3	4	5	6	7	8	9	&	-	\$	@	
.	•	,	?	¿	!	¡	'	'	<	>	-	□	□	
Ä	Â	Á	À	Ã	Å	Ë	Ê	É	È	Ï	Î	Í	Ì	Ñ
Ö	Ô	Ó	Ò	Õ	Ü	Û	Ú	Ù	Æ	Œ	Ç	Ø	ß	
ä	â	á	à	ã	å	ë	ê	é	è	ï	î	í	ì	ñ
ö	ô	ó	ò	õ	ü	û	ú	ù	æ	ij	œ	ç	ø	ß

3-letters / 2-letters



JANOME SEWING MACHINE CO., LTD
