

# **INSTRUCTION BOOK**

MODEL **712T**

---

## TABLE OF CONTENTS

---

### SECTION I ESSENTIAL PARTS

Names of Parts .....	2 ~ 3
Standard Accessories .....	3
How to Install the Spool Pin .....	4
Fundamentals of Operation .....	4

### SECTION II GETTING READY TO SEW

Thread and Needle Chart .....	5
Changing Needles .....	6
Raising or Lowering the Presser Foot .....	7
To Detach and Attach the Foot Holder .....	7
To Snap the Presser Foot On and Off .....	7
Removing the Bobbin .....	8
Setting Spool .....	8
Winding the Bobbin .....	9
Inserting the Bobbin .....	10
Threading the Machine .....	11
Drawing up Bobbin Thread .....	12
Balancing Needle Thread Tension .....	12
* Auto-tension .....	12
* Manual Needle Thread Tension .....	12
Pattern Selector Dial .....	13
Stitch Length Dial .....	13
* Selecting Stitch Length .....	13
* Selecting Stretch Stitch Patterns .....	13

Dropping the Feed Dogs .....	14
Reverse Stitch Lever .....	14

### SECTION III SEWING

Straight Stitch .....	15 ~ 16
Zigzag Stitch .....	16
Overcasting .....	17
Triple Stitch .....	17
Blind Hemming .....	18
Buttonhole .....	19 ~ 20
Tricot Stitch .....	20
Zipper Application .....	21 ~ 22
Feather Stitch .....	23
Stretch Stitch Patterns .....	23
Rolled Hem .....	24

### SECTION IV CARE OF YOUR MACHINE

Cleaning the Bobbin Holder .....	25
Cleaning the Hook Race and Feed Dog .....	25 ~ 26
Resetting the Bobbin Holder and Needle Plate .....	26
Oiling the Machine .....	27
Troubleshooting .....	28 ~ 29

## SECTION I ESSENTIAL PARTS

### • Names of Parts

1. Reverse stitch lever
2. Stitch length dial
3. Bobbin winder stopper
4. Bobbin winder spindle
5. Spool pin
6. Pattern selector dial
7. Thread tension dial
8. Bobbin winder thread guide
9. Upper thread guide
10. Thread take-up lever
11. Face plate
12. Thread cutter
13. Presser bar
14. Foot holder
15. Thumb screw
16. Feed dog
17. Needle plate
18. Bobbin
19. Needle clamp
20. Needle clamp screw
21. Needle
22. Slide plate

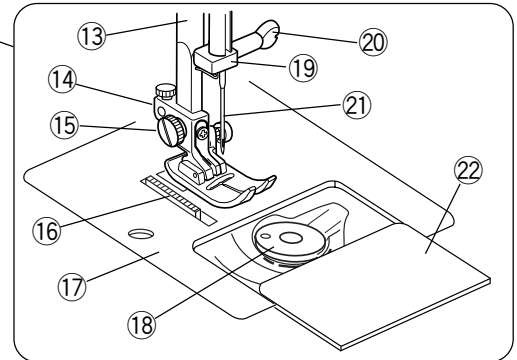
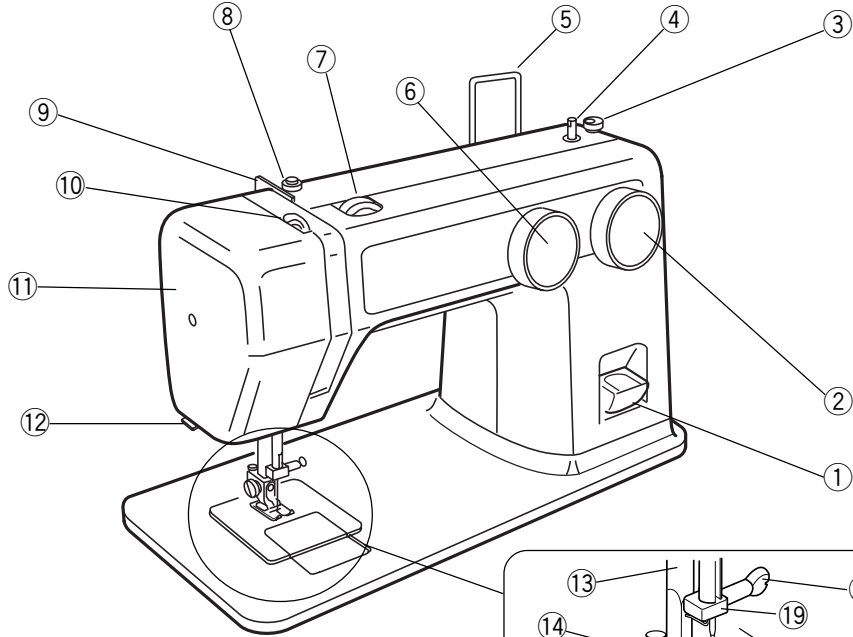

- 23. Handwheel
- 24. Stop motion knob
- 25. Presser foot lifter

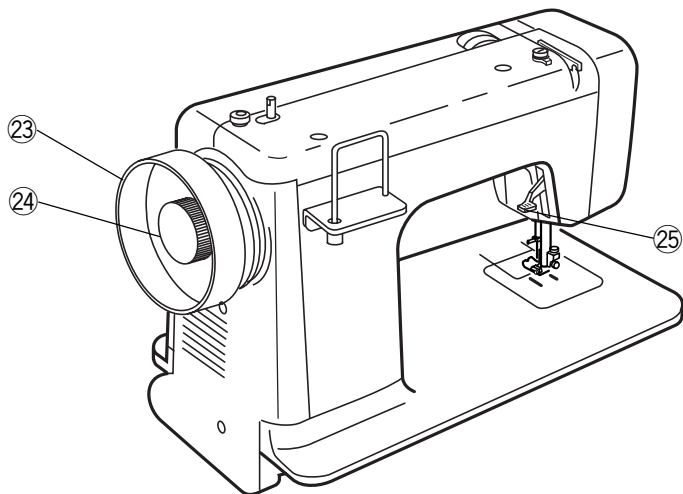

## • Standard Accessories

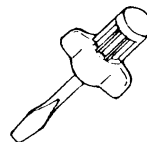

Screwdriver

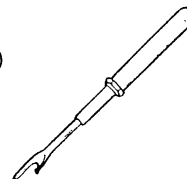

Seam ripper

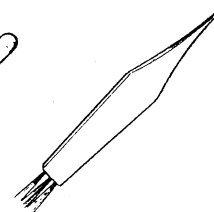

Lint brush

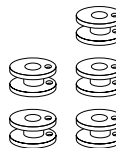

Bobbins

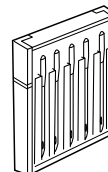

Set of needles

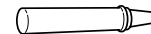

Oil



E: Zipper foot

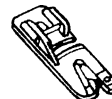

D: Hemmer foot



C: Overedge foot

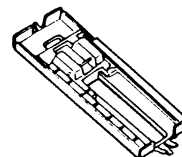

J: Sliding buttonhole foot



G: Blind stitch foot

## • How to Install the Spool Pin

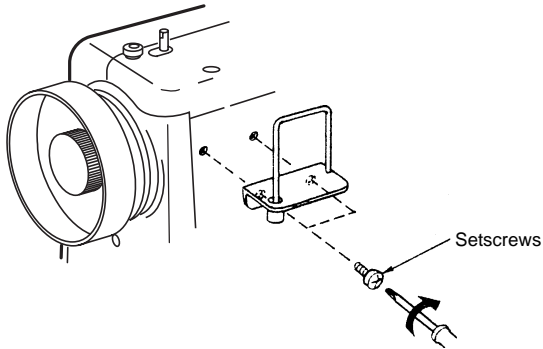

Spool pin and two setscrews are packed separately to prevent damage in transit.

After unpacking, attach the spool pin holder with a screwdriver, as shown in illustration.

## • Fundamentals of Operation

### For Your Safety

1. While in operation, always keep your eyes on the needle, and do not touch any moving parts such as the take-up lever, handwheel or needle.
2. Do not run the machine:
  - \* When making any adjustment in the needle area, such as threading needle, changing needle, or threading bobbin, etc.
  - \* When attaching or removing parts.
  - \* When cleaning the machine.

### Before Using the Machine

- Wipe the machine with a clean cloth to remove any dust or oil.
- To replace presser foot and needle, follow the guides in the instruction book.
- When setting up the machine for sewing, test the stitches on a small piece of the fabric with the threads that will be used for actual sewing.

### For Longer Life of the Machine

- Do not expose the machine to direct sunlight for long periods of time.
- Do not store the machine in an area of high humidity.
- Handle the machine with care to avoid dropping or bumping.

## SECTION II GETTING READY TO SEW

### • Thread and Needle Chart

	Fabrics	Threads	Needle Size
<b>Light weight</b>	Crepe de Chine, Voile Lawn, Organdy, Georgette, Tricot	Fine Silk Fine Cotton Fine Synthetic Fine Cotton Covered Polyester	9 or 11
<b>Medium weight</b>	Linens, Cotton, Pique, Serge, Double Knits, Percale	50 Silk 50 to 80 Cotton 50 to 60 Synthetic Cotton Covered Polyester	11 or 14
<b>Heavy weight</b>	Denim, Tweed, Gabardine, Coating, Drapery and Upholstery Fabric	50 Silk 40 to 50 Cotton 40 to 50 Synthetic Cotton Covered Polyester	14 or 16

- In general, fine thread and needles are used for sewing thin fabrics, and thicker threads and needles are used for sewing heavy fabrics.

Always test thread and needle size on a small piece of fabric which will be used for actual sewing.

- Use the same thread for needle and bobbin.

- When sewing stretch, very fine fabric or synthetics, use a BLUE TIPPED needle. The blue tipped needle effectively prevents skipped stitches.

- When sewing very fine fabrics, use a piece of stabilizer to prevent thread distortion.

### ( To Select a Suitable Needle )

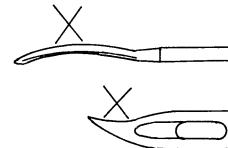

- \* A number indicating the size of needle is marked on the stem.

The higher the number, the thicker the needle.

- \* A BLUE TIPPED needle is supplied with the machine.
- \* Do not use any needle which is bent or blunt.

## • Changing Needles

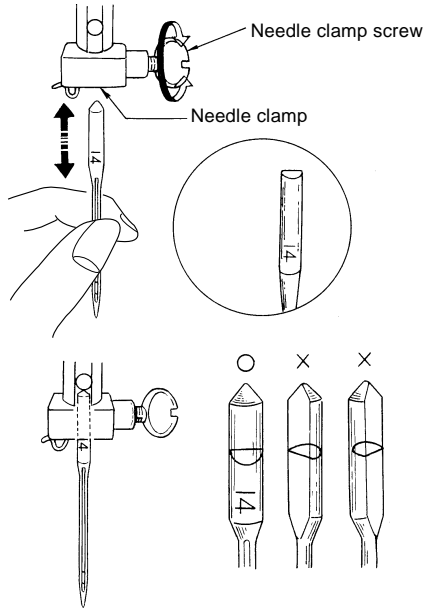

Raise the needle by turning the handwheel toward you and lower the presser foot.

Loosen the needle clamp screw by turning it toward you.

Remove the needle from the clamp.

Insert the new needle into the needle clamp with the flat side facing to the back.

When inserting the needle into the clamp, push it up as far as it will go and tighten the clamp screw firmly with the screwdriver.

## • Raising or Lowering the Presser Foot

The presser foot lifter raises or lowers your presser foot.

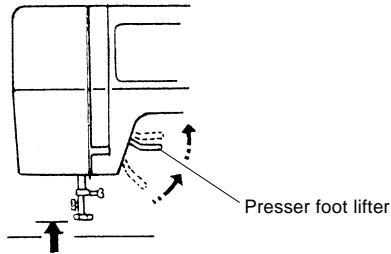

## • To Detach and Attach the Foot Holder

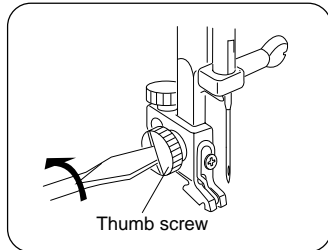

### <To Detach>

Remove the thumb screw by turning it counter clockwise with the screwdriver.

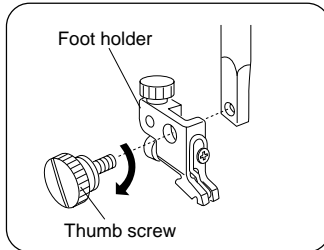

### <To Attach>

Match the hole in the foot holder with the threaded hole in the presser bar. Fit the thumb screw into the hole. Tighten the thumb screw by turning it clockwise.

## • To Snap the Presser Foot On and Off

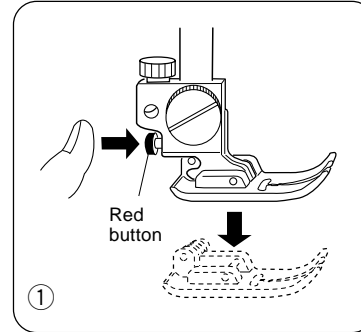

- ① Press the red button on the back of the foot holder. The presser foot will drop off.

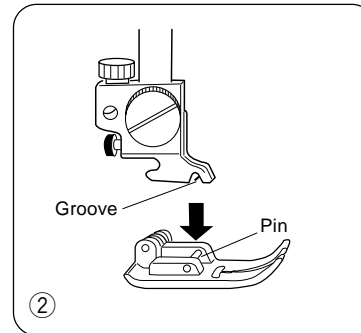

- ② Place the presser foot so the pin on the foot lies just under the groove of the foot holder. Lower the presser foot lifter to lock the foot in place.



## • Removing the Bobbin

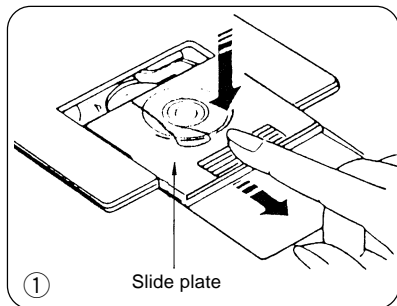

- ① Gently push the slide plate down and slide it toward you.

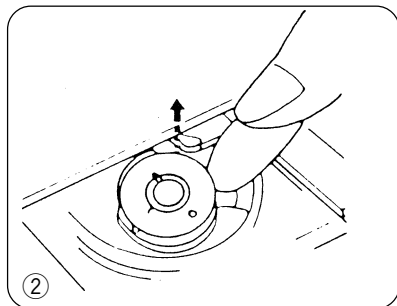

- ② Lift out the bobbin, as shown.

## • Setting Spool

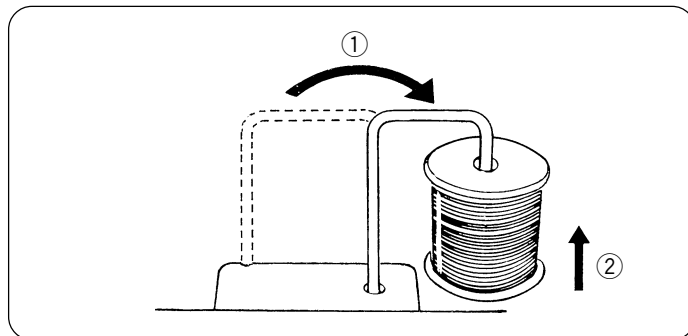

- ① Turn the spool pin.
- ② Set the spool from the bottom end of the spool pin as illustrated.

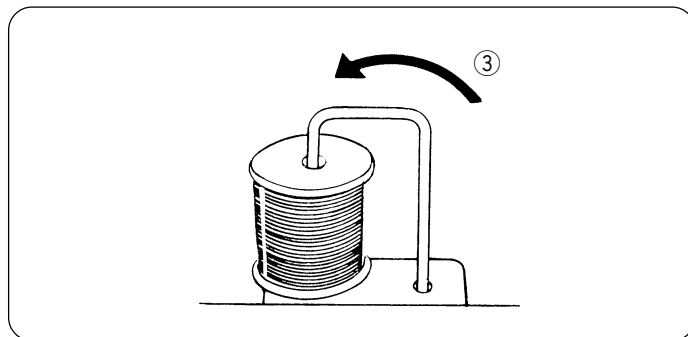

- ③ Return the spool pin to its original position.

## • Winding the Bobbin

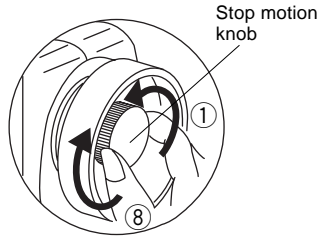

- 1 Turn the stop motion knob counterclockwise to disengage clutch.

- 3 Bobbin winder thread guide

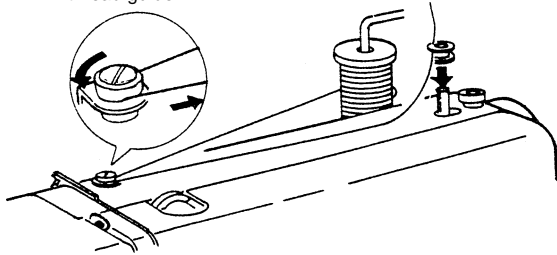

- 2 Draw the thread from the spool.
- 3 Guide the thread around the bobbin winder thread guide.

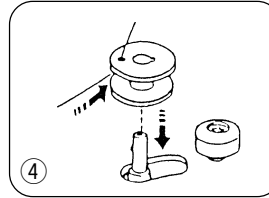

- 4 Insert the thread through the hole in the bobbin from inside to outside as shown.

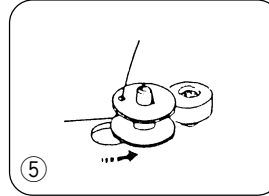

- 5 Put the bobbin on the bobbin winder spindle, and push it to the right.

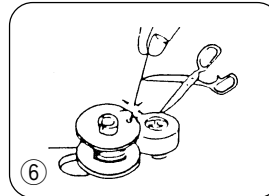

- 6 While holding the free end of the thread with your hand, pedal the machine. Stop the machine when the bobbin has made a few turns, and cut the thread close to the hole in the bobbin.

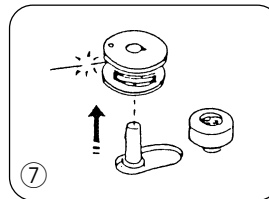

- 7 Pedal the machine and wind the thread until the bobbin stops. Move the bobbin winder spindle to its original position (left), and cut the thread.

- 8 Turn the stop motion knob clockwise to engage clutch.

\* The machine will not sew until the stop motion knob is tightened.

## • Inserting the Bobbin

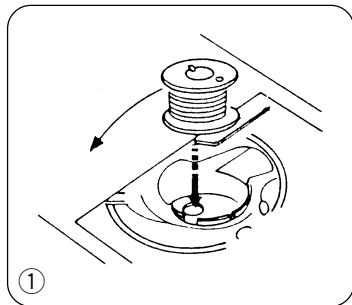

- ① Place the bobbin in the bobbin holder with the thread end unwinding in the clockwise direction.

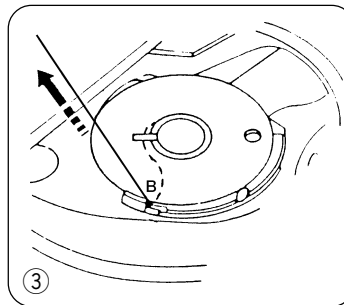

- ③ Continue to draw the thread lightly until the thread slips into notch "B". Pull out about 15 cm (6") of thread.

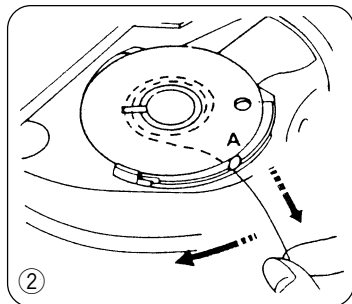

- ② Guide the thread into the notch "A" on the front side of the bobbin holder. Draw the thread to the left, sliding it between the tension spring blades.

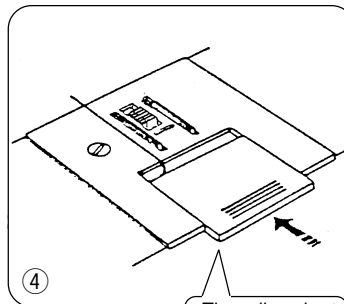

- ④ Close the side plate. Check the threading by referring to the chart shown on the side plate.

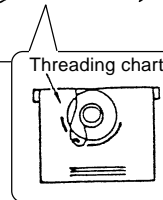

## • Threading the Machine

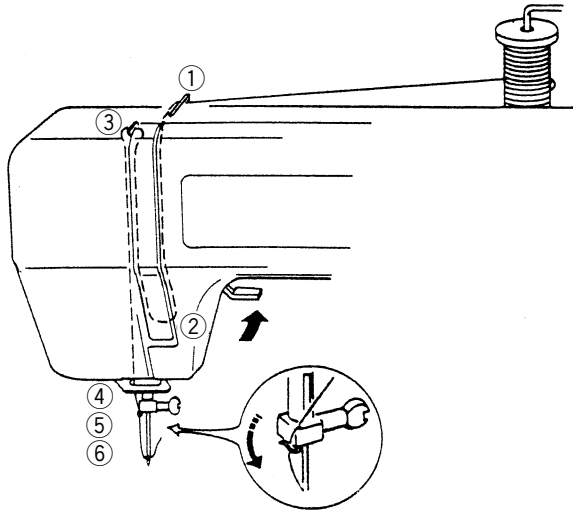

Raise the thread take-up lever to its highest position by turning the handwheel towards you. Raise the presser foot with the presser foot lifter and pass the thread in the order from ① to ⑥.

- ① Draw the thread into the thread guide using both hands.
- ② While holding the thread near the spool, draw the thread down into the tension area and then around the check spring holder.
- ③ Firmly draw the thread from right to left over the take-up lever and down into the take-up lever eye.
- ④ Then draw the thread down and slip it into the lower thread guide.
- ⑤ Draw the thread down and slip it into the needle bar thread guide on the left.
- ⑥ Thread the needle eye from front to back.

**NOTE:** You may want to cut the end of the thread with sharp scissors for easier needle threading.

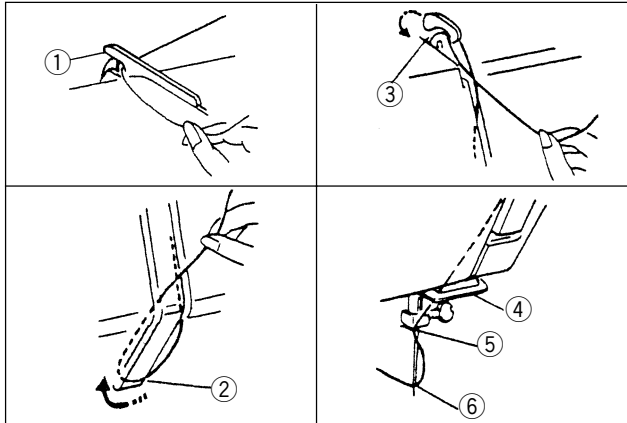

## • Drawing up Bobbin Thread

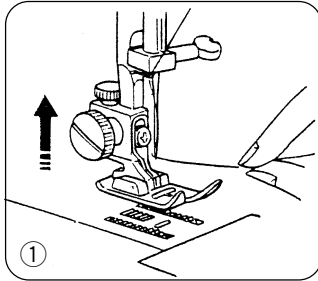

- ① Raise the presser foot and hold the needle thread lightly with your left hand.

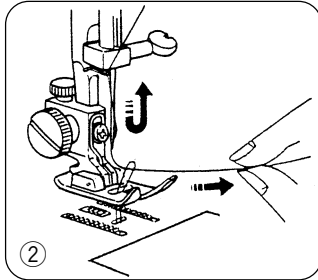

- ② Turn the handwheel towards you with your right hand until the needle goes down, and continue to turn the handwheel until the take-up lever is at its highest position. Lightly pull on the needle thread to draw up a loop of the bobbin thread.

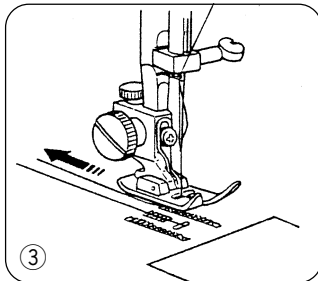

- ③ Pull 15 cm (6") of both threads back and under the presser foot.

## • Balancing Needle Thread Tension

### \* Auto-tension

Set "AUTO" for ordinary sewing to get well-balanced tension.

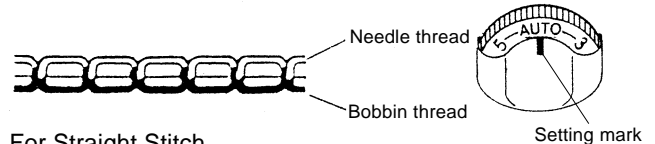

#### ◦ For Straight Stitch

The ideal straight stitch will have threads locked between the two layers of fabric.

#### ◦ For Zigzag Stitch

In the correct zigzag stitch, the bobbin threads will not show on the right side of fabric and the needle threads will show slightly on the wrong side of fabric.

### \* Manual Needle Thread Tension

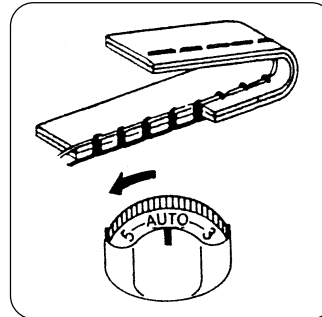

Loosen the needle thread tension by moving the dial to a lower number.

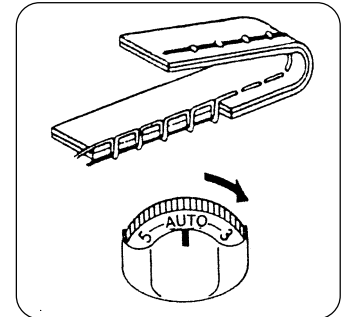

Tighten the needle thread tension by moving the dial to a higher number.

## • Pattern Selector Dial

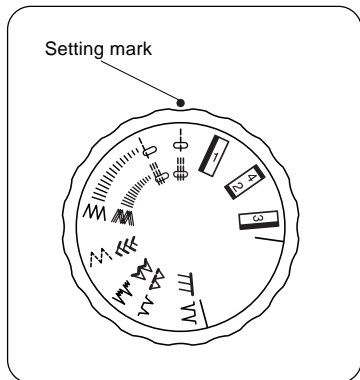

Turn the handwheel with your hand until the tip of needle is out of fabric. Select the stitch by turning the pattern selector dial.

**NOTE:** Do not turn the pattern selector dial while needle is in material.

Pattern							
Stitch length dial		1 ~ 4	0.3 ~ 4	0.5 ~ 2	1 ~ 3		2 ~ 3
Stretch stitch patterns							
Stitch length dial		S. S.					

## • Stitch Length Dial

### \* Selecting Stitch Length

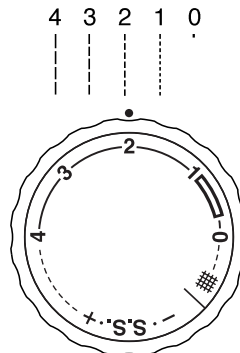

The higher the number, the longer the stitch length. You can select the suitable stitch length for most fabrics.

### \* Selecting Stretch Stitch Patterns

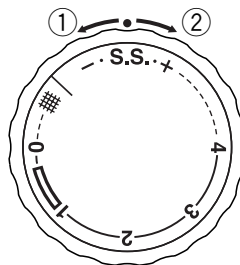

When sewing stretch stitch, set the length dial at "S.S.". If forward and reverse feeds become unbalanced due to the type of fabric, correct the balance as follows: When patterns are compressed, correct it by turning the dial in the direction ① so that the setting mark indicates "S.S." to "+". When patterns are drawn out, correct it by turning the dial in the direction ② so that the setting mark indicates "S.S." to "-".

- **Dropping the Feed Dogs**

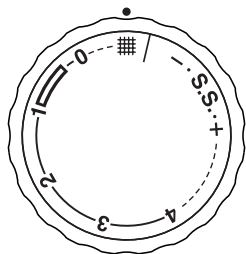

To drop the feed dogs, turn the stitch length dial to the “” mark.

- **Reverse Stitch Lever**

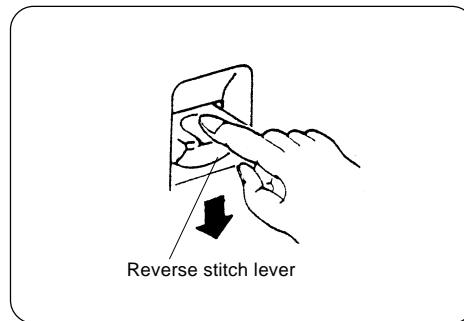

Fabric is fed in reverse while the lever is pressed. When it is released, fabric is fed forward.

## SECTION III SEWING

### • Straight Stitch

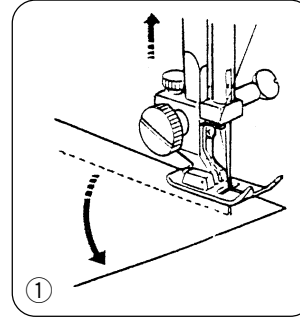
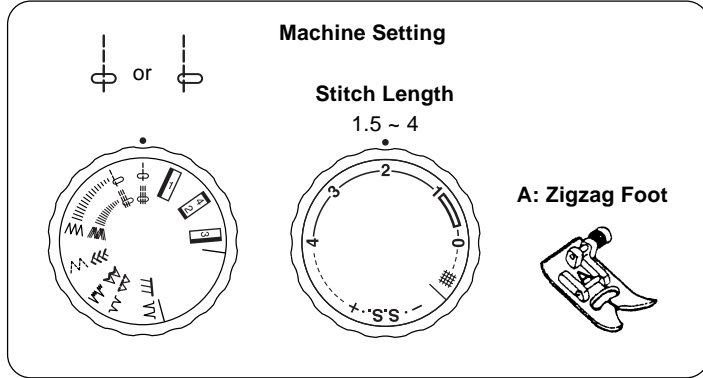

### <<Changing Sewing Direction>>

- ① Bring the needle down into the fabric, and raise the presser foot.

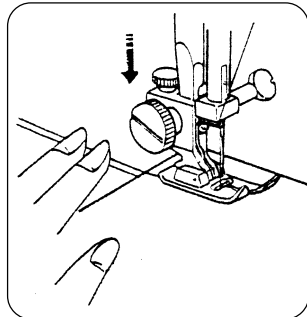

### << Starting Sewing >>

While holding the threads with your left hand, turn the handwheel toward you to bring the needle into the fabric where you wish to start sewing.

Lower the presser foot, and then start sewing slowly.

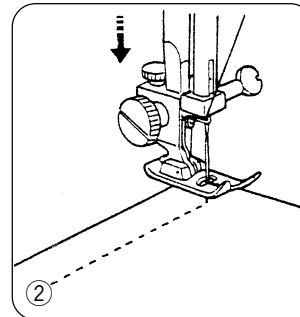

- ② Then pivot the fabric to the desired direction. Lower the foot to start sewing.



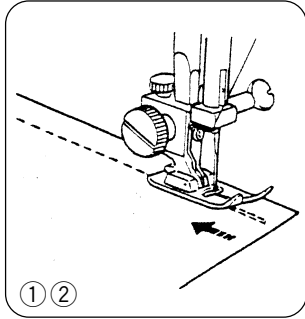

### <<Securing Seams>>

- ① For fastening the end of seams, press the reverse stitch lever and sew several reverse stitches.
- ② Turn the handwheel so that the take-up lever is at its highest position. Raise the presser foot and draw the fabric out to the rear.

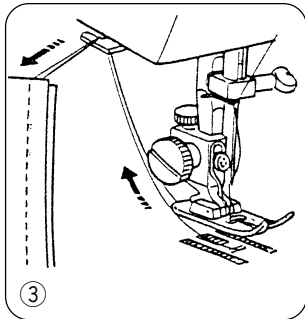

- ③ Cut the threads with the thread cutter, leaving the thread ends the proper length for starting the next seam.

### • Zigzag Stitch

**Machine Setting**

**Stitch Length**  
0.3 ~ 4

**A: Zigzag Foot**

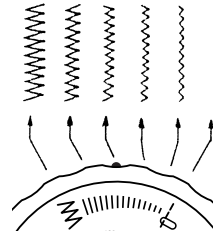

Zigzag width can be adjusted within the range illustrated by the symbol.

## • Overcasting

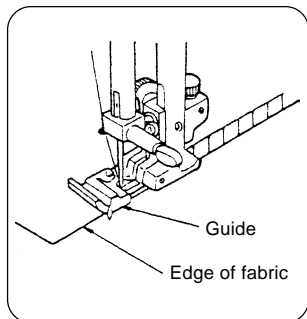
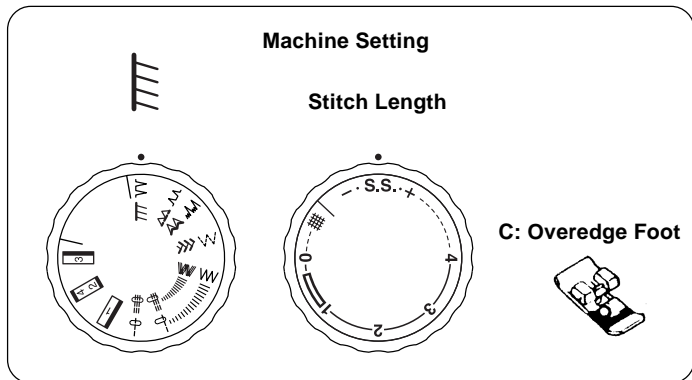

### Here's How

Place the fabric under the presser foot so that the stitches are made over the edge.

**NOTE:** When using stretch knit fabric, use a blue tip needle, which effectively prevents skipped stitches.

## • Triple Stitch

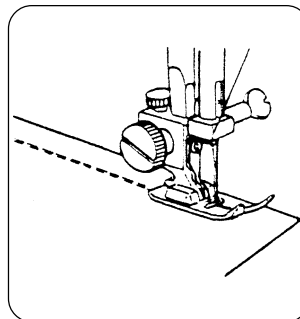
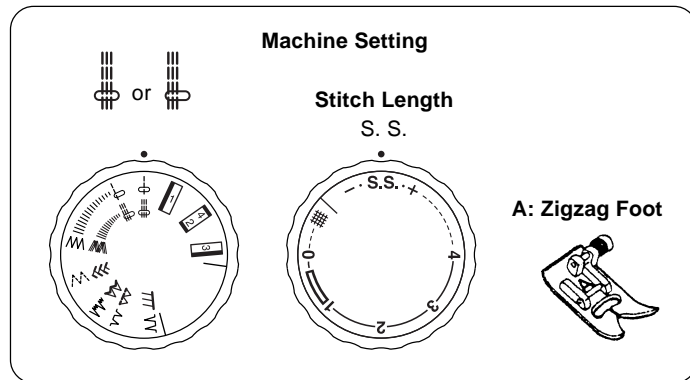

This stitch is formed with two stitches forward and one stitch backward. Because of this, the seam is very strong and cannot be ripped out easily. Garments should be basted for fitting before using this stitch.

## • Blind Hemming

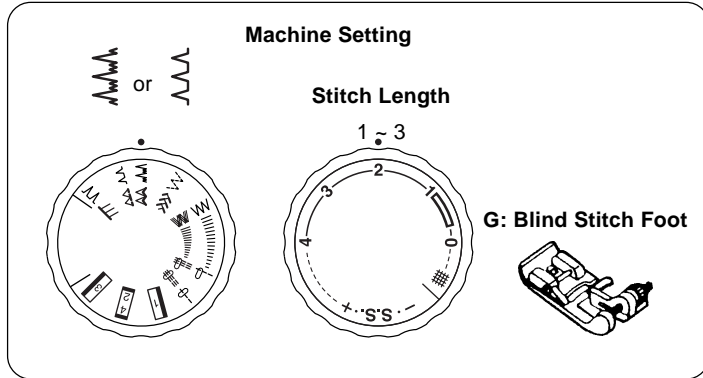

### <<How to Fold the Fabric>>

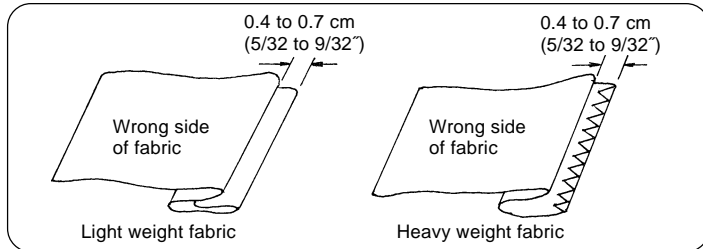

On heavy weight fabrics that ravel, the raw edge should be overcast first. On lightweight fabrics the raw edge can be turned under and pressed.

Fold the hem the desired amount and pin in place.  
Fold hem under the fabric as illustrated.

### <<How to Sew>>

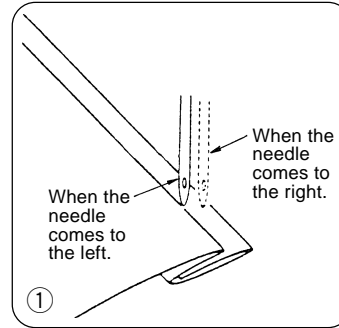

① Position the fabric on the machine so that the needle just pierces the folded edge of the fabric when the needle comes over to the extreme left side. Lower the presser foot.

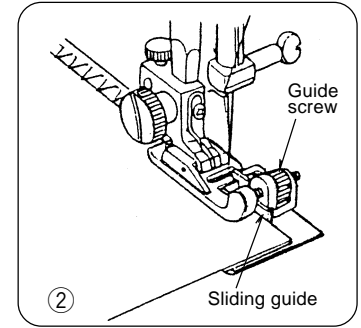

② Turn the guide screw and move the sliding guide against the folded edge. Sew the folded edge guiding along the sliding guide.

### <<How to Set the Guide>>

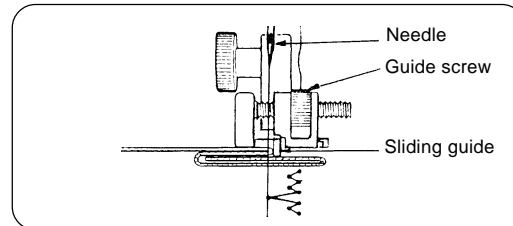

## • Buttonhole

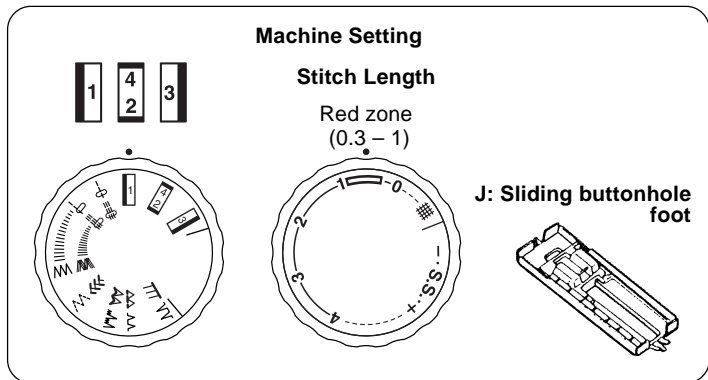

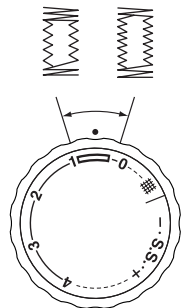

Always make a practice buttonhole on a scrap of fabric you plan to use. Try the buttonhole with the button you will use.

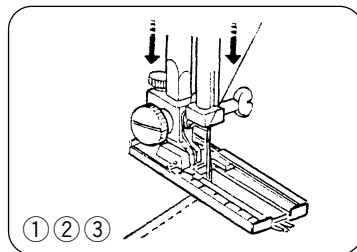

The symbol “” (red zone) on the stitch length dial indicates the range of adjustment for the buttonhole.

To adjust for coarser stitch for the buttonhole, turn the dial toward “1”. For denser stitch for the buttonhole, turn the dial toward “0”.



- ① Set the pattern selector dial at “”.
- ② Lead both threads to the left.
- ③ Lower the needle into the fabric, where the buttonhole is to start, and lower the foot.

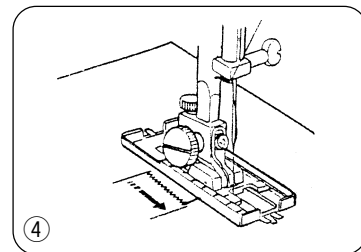

- ④ Sew down the left side of the buttonhole to the bottom end. Raise the needle.

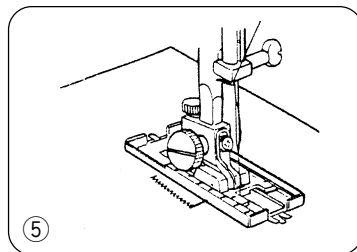

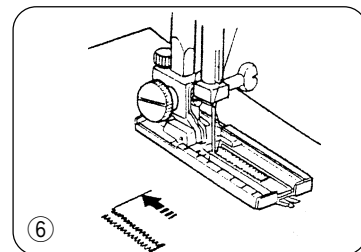

- ⑤ Set the pattern selector dial at “” , and sew 5 stitches of bartack, then raise the needle from the fabric.

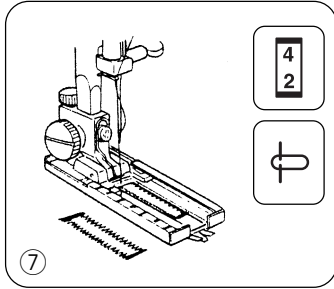

- ⑥ Set the pattern selector dial at “” . Sew the right side of the buttonhole. Stop the machine when you are directly opposite the first stitch on the left side, and raise the needle.



- ⑦ Set the pattern selector dial at “”.
- Sew 5 stitches of bartack, and raise the needle from the fabric.
- Then set the pattern selector dial at “” and sew a few stitches to secure the seam.

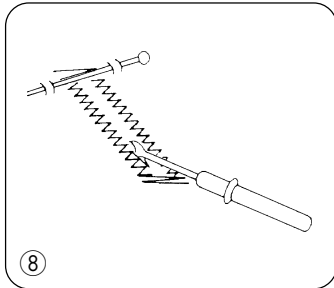

- ⑧ Remove the fabric from the machine, and cut the sewing threads.
- Pierce a pin inside the bartack. Then cut the opening with a seam ripper.
- Be careful not to cut the stitches.

## • Tricot Stitch

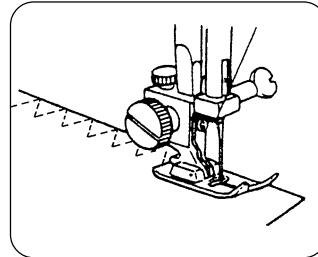
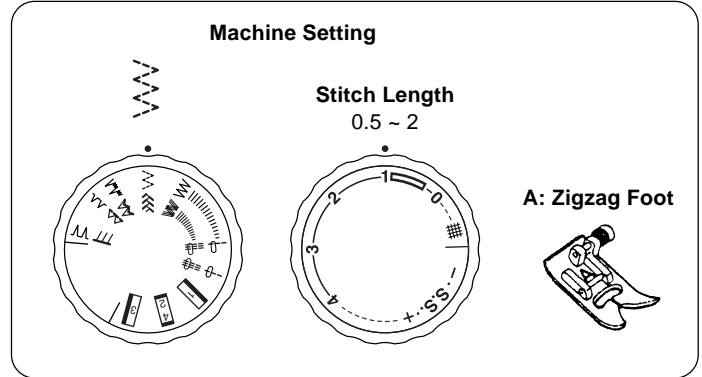

The tricot stitch is used to finish seam allowance on synthetics and other fabrics that tend to pucker.

The stitch is excellent for darning and mending tears in fabric as well.

## • Zipper Application

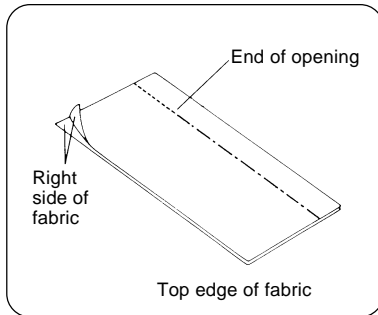
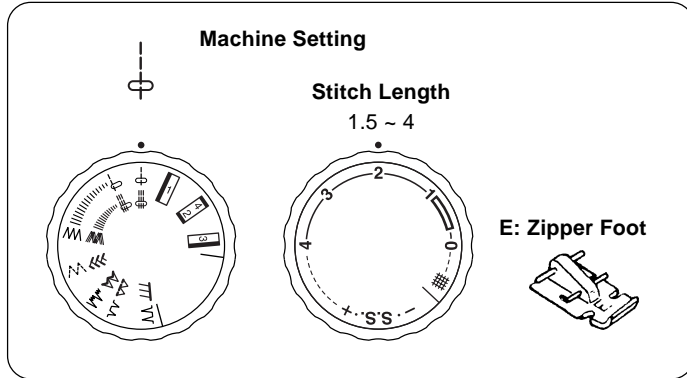

### <<Fabric Preparation>>

Put the right side of the fabric together and sew to the end of the zipper opening. Use the reverse to lock the stitches.

Baste the zipper opening with stitch length at “4” and top thread tension at “3”.

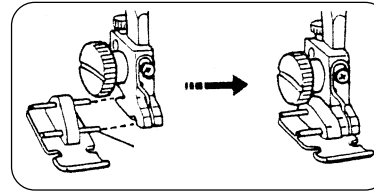

### <<To attach the zipper foot>>

- To sew on the left side of the zipper, attach the zipper foot with the pin on the right hand side.

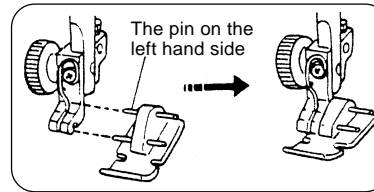

- To sew on the right side of the zipper, attach the zipper foot with the pin on the left hand side.

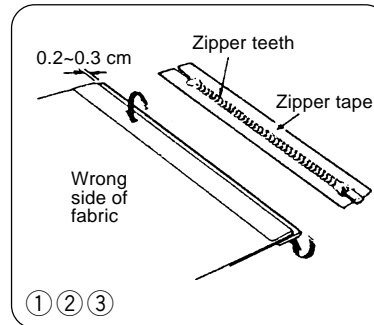

### <<To Sew>>

- ① Set the stitch length at 2 and the top thread tension at “AUTO”. Fold back the left seam allowance as shown.
- ② Turn under the right seam allowance to form a 0.2 to 0.3 cm (1/8”) fold.
- ③ Place the zipper teeth next to the 0.2 to 0.3 cm (1/8”) fold with the bottom end of the zipper matching the bottom end of the zipper opening. Pin in the place.

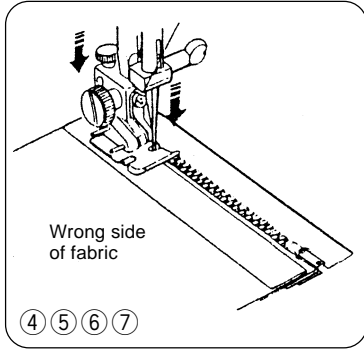

- ④ Attach the zipper foot with the pin on the right hand side.
- ⑤ Lower the zipper foot at the bottom of the zipper so that the needle pierces the fold and the zipper tape.
- ⑥ Sew through the fold and the zipper tape to the point where the slider begins.
- ⑦ Lower the needle to hold the fabric and raise the presser foot.

- ⑧ Open the zipper.
- ⑨ Lower the presser foot and stitch the rest of the seam.

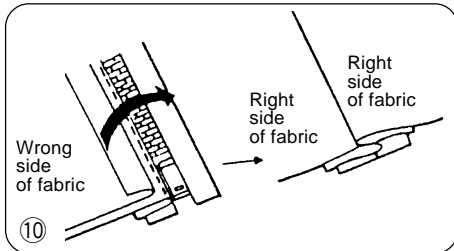
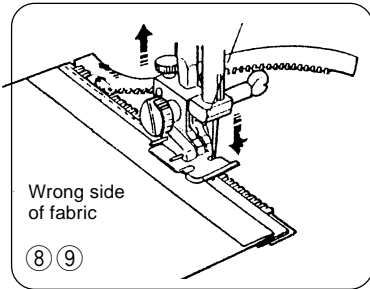

- ⑩ Close the zipper and turn the fabric right side up.

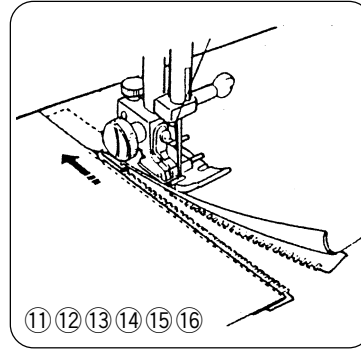

- ⑪ Remove the zipper foot and attach the zipper foot with the pin on the left hand side.
- ⑫ Stitch across the bottom of zipper, below the zipper end.
- ⑬ Turn the corner and continue to guide the foot along the zipper teeth, as shown. Stitch through the fabric and zipper tape.
- ⑭ Stop about 5 cm from the top of the zipper.
- ⑮ Lower the needle into the fabric and raise the presser foot.
- ⑯ Remove the basting stitches and open the zipper.

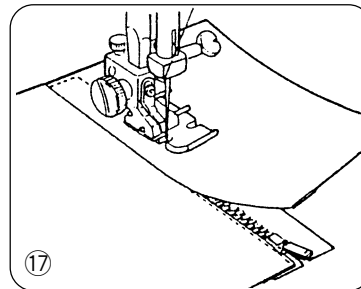

- ⑰ Lower the foot and stitch the rest of the seam. Make sure the fold is even.

## • Feather Stitch

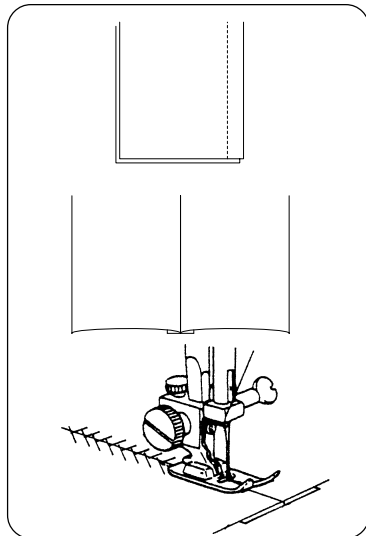
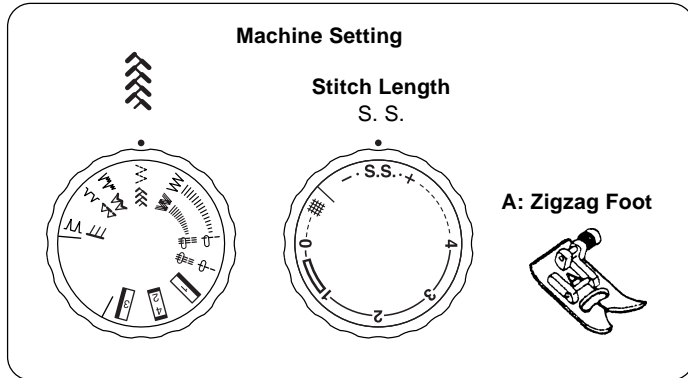

Place right sides of fabric together and seam along the edge.

Spread the fabric open flat with the right side of the fabric facing up.

Sew feather stitch slowly guiding the fabric so the needle catches the folded edge on each side.

## • Stretch Stitch Patterns

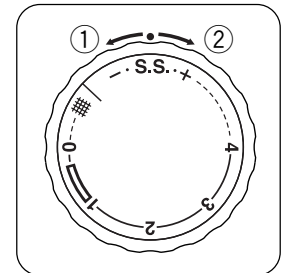
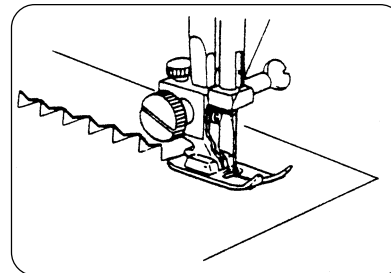
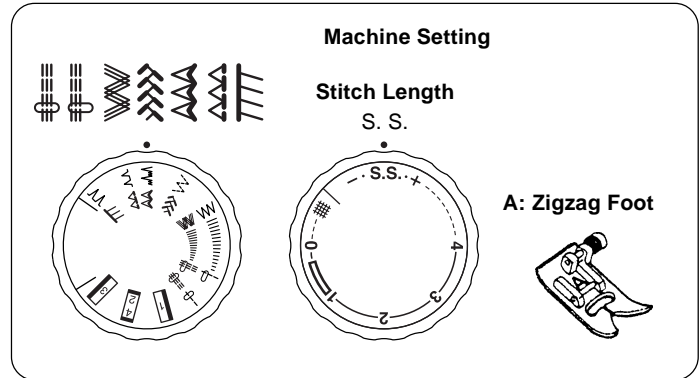

When forward and reverse feeds become unbalanced due to the type of fabric, correct the balance by turning the stitch length dial as follows:

When patterns are compressed, correct it by turning the dial in the direction ①.

When patterns are drawn out, correct it by turning the dial in the direction ②.



## • Rolled Hem

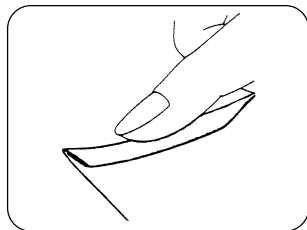
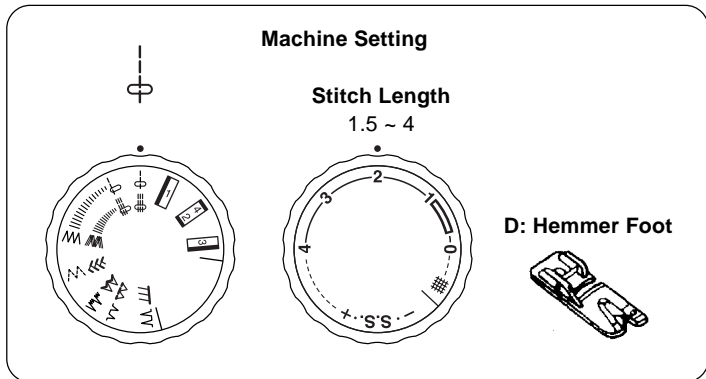

Make a double 0.25 cm (1/8") fold approximately 8 cm (3") in length.

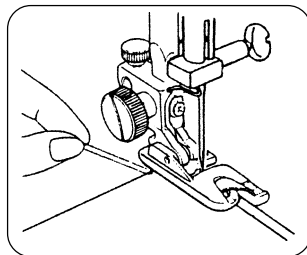

Lower the needle into the fabric at the point where sewing is to begin, then lower the hemmer foot.

Sew 3 or 4 stitches while pulling the needle and bobbin threads.

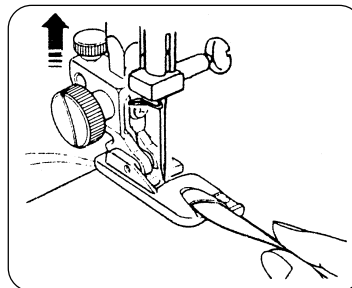

Lower the needle into the fabric and lift the hemmer foot. Insert the folded portion of the fabric into the curl of the hemmer foot.

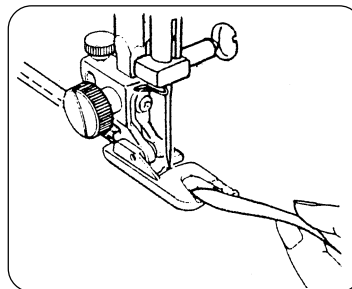

Lower the hemmer foot, and then sew by lifting up the edge of the fabric to keep it feeding smoothly and evenly.

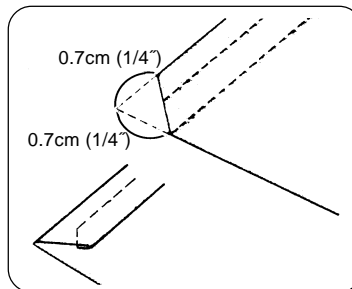

To reduce bulk, trim about 0.7 cm (1/4") from corners as illustrated.

## SECTION IV CARE OF YOUR MACHINE

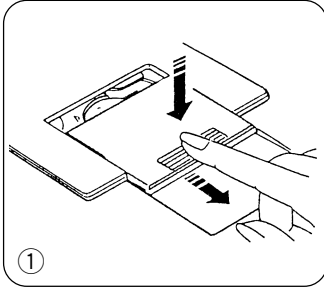

\* Before cleaning, turn the handwheel toward you to raise the needle.

### • Cleaning the Bobbin Holder

① While pushing the front end of slide plate, slide it toward you as far as it will go.

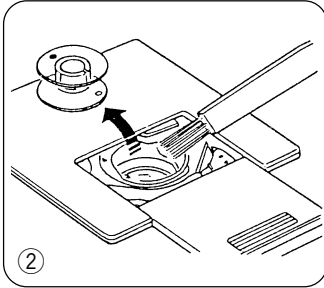

② Take out the bobbin, and remove lint with a lint brush.

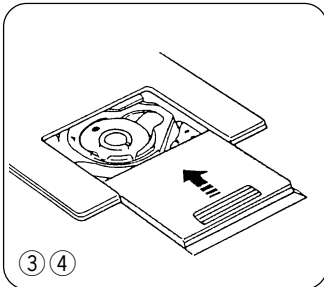

③ Insert the bobbin.

④ Close the slide plate.

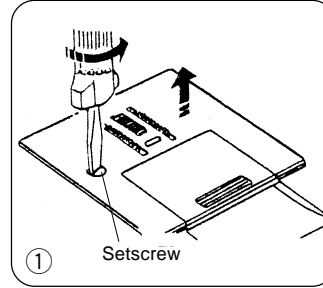

### • Cleaning the Hook Race and Feed Dog

① Remove the needle and presser foot. Remove the setscrew on the left hand side of the needle plate with the screwdriver.

Remove the needle plate.

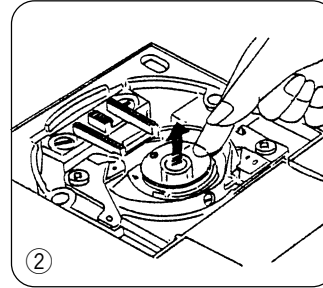

② Take out the bobbin.

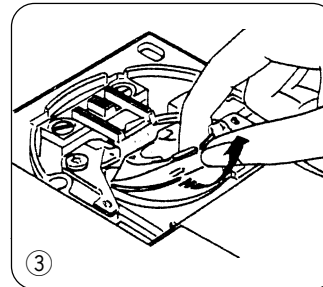

③ Lift up the front end of bobbin holder to remove it.

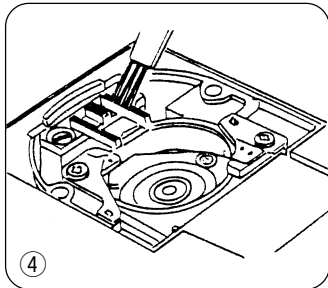

- ④ Brush off the lint on the feed dogs.

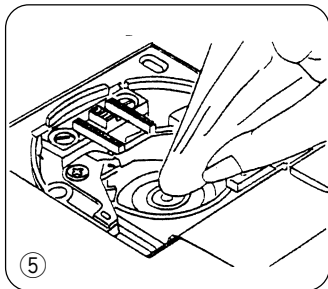

- ⑤ Wipe the hook race with a soft dry cloth.

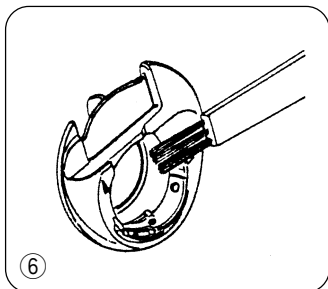

- ⑥ Clean the bobbin holder with a lint brush and a soft dry cloth.

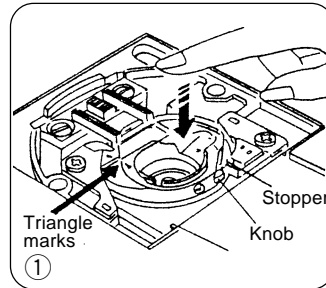

### • Resetting the Bobbin Holder and Needle Plate

- ① Line up the triangle marks and position the bobbin holder so that the knob fits next to the stopper in the hook race.

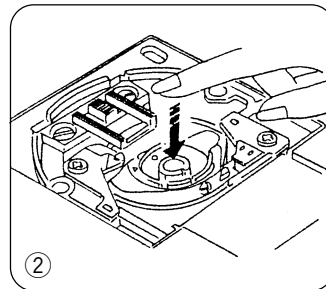

- ② Put the bobbin in.

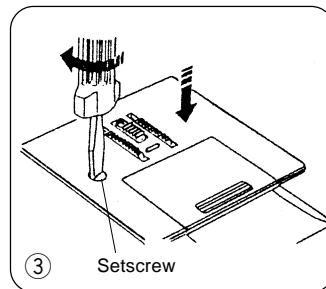

- ③ Attach the needle plate with setscrew. Insert the needle, and attach the presser foot.

## • Oiling the Machine

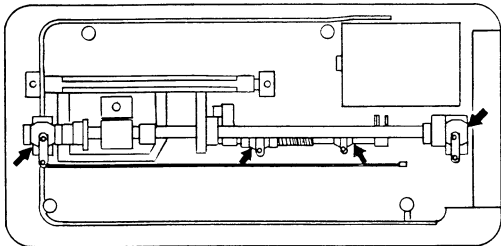
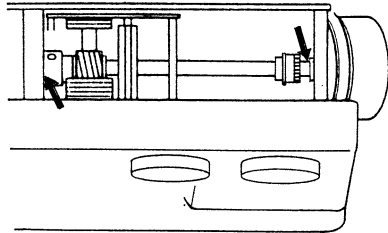
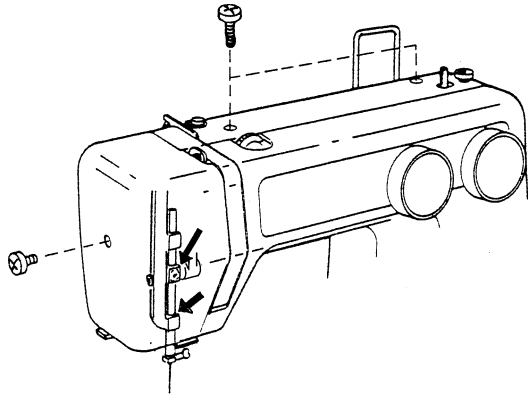

For a machine in constant use, oil two or three times a year.

If the machine does not work smoothly due to standing idle for some time, apply a few drops of oil at the oiling points, and run the machine rapidly for a minute.

Wipe excess oil before sewing.

Unscrew and remove the face plate.

Apply a few drops of fine quality sewing machine oil to the points indicated by the arrows in the illustration.

Remove the two screws and take off the top cover.

Apply a few drops of fine quality sewing machine oil to the points indicated by the arrows in the illustration.

Lay the machine over on its back and apply a few drops of fine quality sewing machine oil to the points indicated by the arrows in the illustration.

• Troubleshooting

Condition	Cause	Reference
<b>The machine does not run smoothly and is noisy.</b>	<ol style="list-style-type: none"> <li>1. Threads have been caught in hook mechanism.</li> <li>2. The feed dog is packed with lint.</li> </ol>	See Pages 25 ~ 26
<b>The needle thread breaks.</b>	<ol style="list-style-type: none"> <li>1. The needle thread is not threaded properly.</li> <li>2. The needle thread tension is too tight.</li> <li>3. The needle is bent or blunt.</li> <li>4. The needle is incorrectly inserted.</li> <li>5. The fabric is not being drawn to the back when sewing is finished.</li> <li>6. The thread is either too heavy or too fine for the needle.</li> </ol>	See Page 11 See Page 12 See Page 5 See Page 6 See Page 16 See Page 5
<b>The bobbin thread breaks.</b>	<ol style="list-style-type: none"> <li>1. The bobbin thread is not threaded properly in the bobbin holder.</li> <li>2. Lint has collected in the bobbin holder and/or tension spring.</li> <li>3. The bobbin does not rotate smoothly.</li> </ol>	See Page 10 See Pages 25 ~ 26 Replace the bobbin.
<b>The needle breaks</b>	<ol style="list-style-type: none"> <li>1. The needle is incorrectly inserted.</li> <li>2. The needle is bent or blunt.</li> <li>3. The needle clamp screw is loose.</li> <li>4. The tension of the needle thread is too tight.</li> <li>5. The fabric is not drawn to the back when sewing is finished.</li> <li>6. The needle is too fine for the fabric being sewn.</li> <li>7. The pattern selector dial had been turned while the needle was in the material.</li> </ol>	See Page 6 See Page 5 See Page 6 See Page 12 See Page 16 See Page 5 See Page 13
<b>Skipped stitches</b>	<ol style="list-style-type: none"> <li>1. The needle is incorrectly inserted.</li> <li>2. The needle is bent or blunt.</li> <li>3. The needle and/or threads are not suitable for the work being sewn.</li> <li>4. A BLUE TIP needle is not used for sewing stretch, very fine fabrics and synthetics.</li> <li>5. The needle thread is not threaded properly.</li> </ol>	See Page 6 See Page 5 See Page 5 See Page 5  See Page 11

Condition	Cause	Reference
<b>Seam Puckering</b>	1. The needle thread tension is too tight. 2. The needle thread and/or bobbin thread is not threaded properly. 3. The needle is too heavy for the cloth being sewn. 4. The stitches are too coarse for the fabric being sewn. * When sewing extremely lightweight materials, place a sheet of paper underneath the fabric.	See Page 12 See Pages 10 ~ 11 See Page 5 See Page 13
<b>Stitches form loops below the work.</b>	1. The needle thread tension is too loose. 2. The needle is either too heavy or too fine for the thread. 3. The needle thread is not threaded properly.	See Page 12 See Page 5 See Page 11
<b>The cloth is not feeding smoothly.</b>	1. The feed dog is packed with lint. 2. The stitches are too fine. 3. The feed dog is not raised after “Drop feed” has been used.	See Pages 25 ~ 26 See Page 13 See Page 14
<b>The machine does not work.</b>	1. A thread is caught in the hook race. 2. Stop motion knob is not tightened.	See Pages 25 ~ 26 See Page 9
<b>The buttonhole stitches are not balanced.</b>	1. The stitch length is not suitable for the fabric being sewn. 2. The work is being pulled or held back.	See Page 13 Do not force the fabric for guiding.
<b>The machine is noisy.</b>	1. The machine is in need of oil. 2. Dust and lint have collected in the hook mechanism. 3. The feed dog is packed with lint.	See Page 27 See Pages 25 ~ 26 See Pages 25 ~ 26



To operate the machine, a treadle operated sewing table is required.

## “INSTALLATION INSTRUCTIONS”

1. Lay the machine backwards with bottom towards you and loosen setscrews.
2. After loosening set screws, position and set the machine onto hinges.
3. Tighten setscrews and swing the machine forward into place.

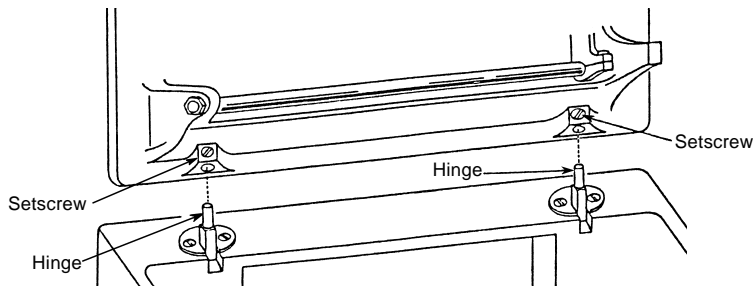

Bottom view of machine showing the position of setscrews

**To install the machine onto a sewing table, refer to the instructions with your sewing table for more details.**