

Instruction Book

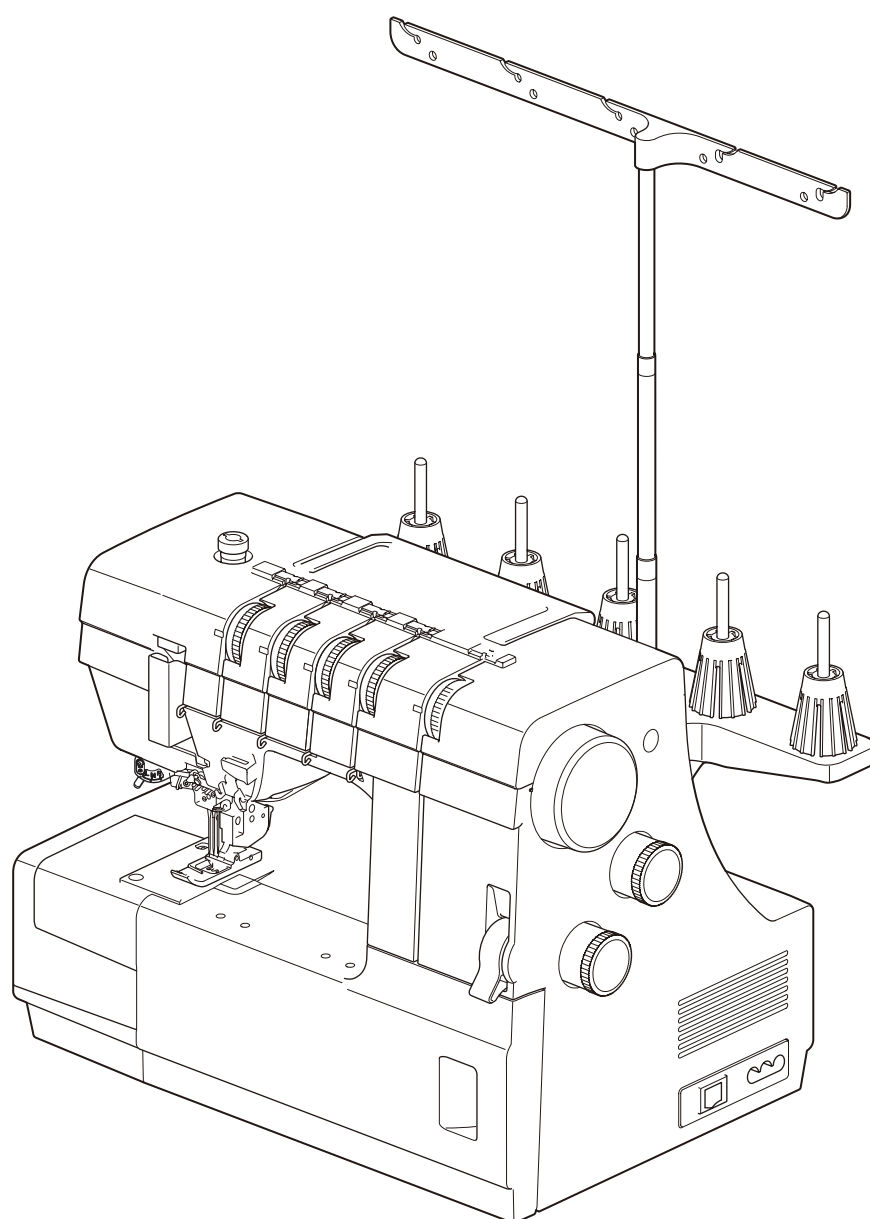

IMPORTANT SAFETY INSTRUCTIONS

When using an electrical appliance, basic safety precautions should always be followed, including the following:

This sewing machine is designed and manufactured for household use only.

Read all instructions before using this sewing machine.

DANGER — To reduce the risk of electric shock:

1. An appliance should never be left unattended when plugged in. Always unplug this sewing machine from the electric outlet immediately after using and before cleaning.

WARNING — To reduce the risk of burns, fire, electric shock, or injury to persons:

1. Do not allow to be used as a toy. Close attention is necessary when this sewing machine is used by or near children.
2. Use this appliance only for its intended use as described in this owner's manual. Use only attachments recommended by the manufacturer as contained in this owner's manual.
3. Never operate this sewing machine if it has a damaged cord or plug, if it is not working properly, if it has been dropped or damaged, or dropped into water. Return this sewing machine to the nearest authorized dealer or service center for examination, repair, electrical or mechanical adjustment.
4. Never operate the appliance with any air opening blocked. Keep ventilation openings of this sewing machine and foot controller free from accumulation of lint, dust and loose cloth.
5. Never drop or insert any object into any opening.
6. Do not use outdoors.
7. Do not operate where aerosol (spray) products are being used or where oxygen is being administered.
8. To disconnect, turn all controls to the off ("O") position, then remove plug from outlet.
9. Do not unplug by pulling on cord. To unplug, grasp the plug, not the cord.
10. Keep fingers away from all moving parts. Special care is required around the sewing machine needle and/or cutting blade.
11. Always use the proper needle plate. The wrong plate can cause the needle to break.
12. Do not use bent needles.
13. Do not pull or push fabric while stitching. It may deflect the needle causing it to break.
14. Switch this sewing machine off ("O") when making any adjustment in the needle area, such as threading the needle, changing the needle, threading the bobbin or changing the presser foot, and the like.
15. Always unplug this sewing machine from the electrical outlet when removing covers, lubricating, or when making any other adjustments mentioned in this owner's manual.

SAVE THESE INSTRUCTIONS

For Europe only:

This appliance can be used by children aged from 8 years and above and persons with reduced physical, sensory or mental capabilities or lack of experience and knowledge if they have been given supervision or instruction concerning use of the appliance in a safe way and understand the hazards involved. Children shall not play with the appliance. Cleaning and user maintenance shall not be made by children without supervision.

For outside Europe (except U.S.A.):

This appliance is not intended for use by persons (including children) with reduced physical, sensory or mental capabilities, or lack of experience and knowledge, unless they have been given supervision or instruction concerning use of the appliance by a person responsible for their safety.

Children should be supervised to ensure that they do not play with the appliance.



Please note that on disposal, this product must be safely recycled in accordance with relevant National legislation relating to electrical/electronic products. If in doubt please contact your retailer for guidance. (European Union only)

TABLE OF CONTENTS

ESSENTIAL PARTS

Names of Parts.....	2
Standard Accessories.....	3

GETTING READY TO SEW

Connecting the Machine to the Power Supply.....	4
Controlling Sewing Speed.....	4
How to Turn the Handwheel.....	5
Opening and Closing the Looper Cover.....	5
Extension Table.....	5
Retractable Sewing Light.....	6
Presser Foot Lifter.....	6
Replacing the Presser Foot.....	7
Adjusting the Presser Foot Pressure.....	8
Adjusting the Stitch Length.....	8
Adjusting the Differential Feed Ratio.....	8
Adjusting the Thread Tension.....	9
Changing Needle.....	10
Setting the Thread Guide Bar.....	11
Setting the Spools.....	11
Threading the machine.....	12
Threading the Looper.....	13
Threading the Needles.....	16
Built-in Needle Threader.....	19
Handy Needle Threader.....	21
Threading the Top Cover Stitch Guides and Spreader..	22

STITCH TYPES AND TENSION SETTINGS

Top Cover Stitch.....	26
Balancing the thread tension.....	27
Triple Cover Stitch.....	28
Balancing the thread tension.....	28
Cover Stitch.....	29
Balancing the thread tension.....	30
Chain Stitch.....	31
Balancing the thread tension.....	31
Stitch and Thread Tension Chart.....	32
Standard to Heavy fabrics.....	32
Fine fabrics.....	33
Beginning and End of the seam.....	34
Beginning of the seam.....	34
End of the seam with thread chain.....	35
End of the seam without thread chain.....	36
Beginning of the seam for top cover stitch.....	38
End of the seam for top cover stitch.....	38
Knotting the threads.....	39
Curling problem.....	39
Skipped stitch.....	39
Hemming with the Cover Stitch.....	40
Free Arm Hemming.....	40
Triple Cover Stitch Applications.....	41

CARE OF YOUR MACHINE

Cleaning the Feed Dogs and Looper Area.....	42
Troubleshooting.....	43

ESSENTIAL PARTS

Names of Parts

- ① Differential feed dial
- ② Stitch length dial
- ③ Handwheel
- ④ Spool stand
- ⑤ Spool holder
- ⑥ Spool pin
- ⑦ Thread guide bar
- ⑧ Thread guide post
- ⑨ Carrying handle
- ⑩ Thread guide plate
- ⑪ Looper thread tension dial
- ⑫ Top cover stitch thread tension dial
- ⑬ Right needle thread tension dial
- ⑭ Center needle thread tension dial
- ⑮ Left needle thread tension dial
- ⑯ Presser foot pressure adjusting screw
- ⑰ Retractable sewing light
- ⑱ Looper
- ⑲ Looper release knob
- ⑳ Looper thread take-up lever
- ㉑ Looper cover
- ㉒ Fine mode switching lever
- ㉓ Power switch
- ㉔ Machine socket
- ㉕ Ventilation openings
- ㉖ Needle threader lever
- ㉗ Thread cutter
- ㉘ Presser foot lifter
- ㉙ Presser foot holder
- ㉚ Extension table
- ㉛ Needle plate
- ㉜ Feed dogs
- ㉝ Attachment mount (for attaching optional accessories)
- ㉞ Presser foot
- ㉟ Left needle (Schmetz EL X 705 90/14)
- ㊱ Center needle (Schmetz EL X 705 90/14)
- ㊲ Right needle (Schmetz EL X 705 90/14)
- ㊳ Built-in needle threader
- ㊴ Top cover stitch spreader
- ㊵ Top cover stitch lever
- ㊶ Top cover stitch release lever

NOTE:

To carry the sewing machine, hold the carrying handle with your hand, and support the sewing machine with the other hand.

NOTE:

Sewing machine design and specifications are subject to change without prior notice.

Standard Accessories

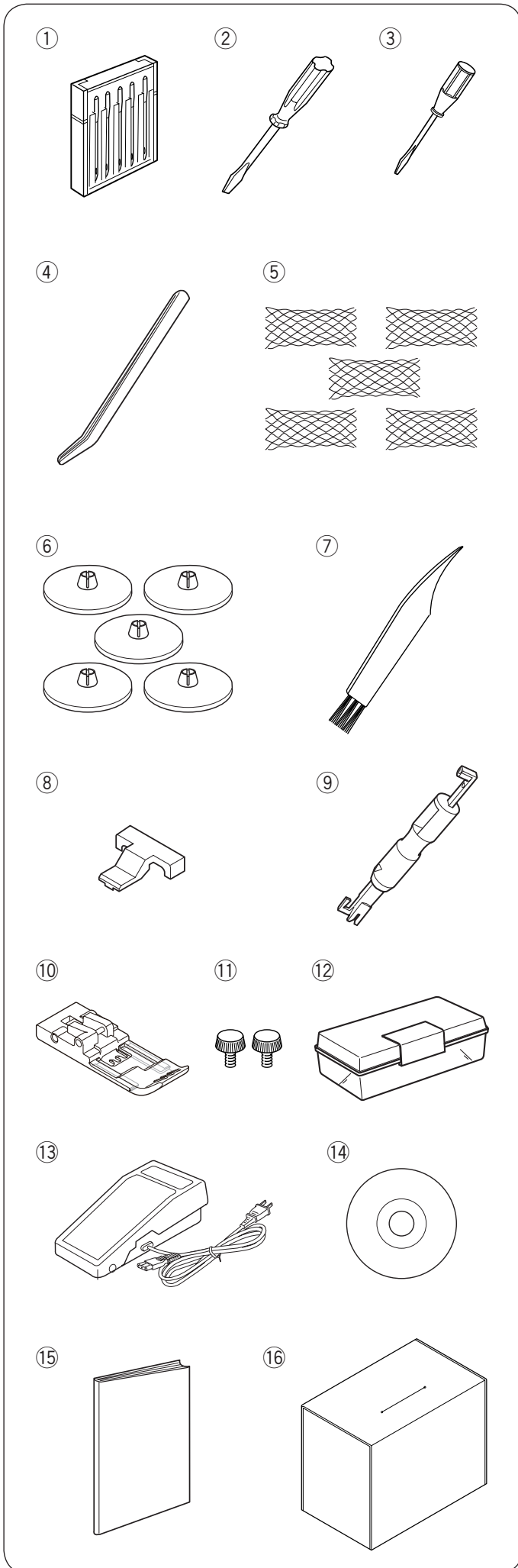

No.	Part Name	Part No.	
①	Set of needles: Schmetz EL X 705 80/12 X 3 Schmetz EL X 705 90/14 X 2	778805005	
②	Screwdriver (Large)	784810002	
③	Screwdriver (Small)	792030005	
④	Tweezers	624801001	
⑤	Net X 5	624806006	
⑥	Spool holder cap X 5	822020503	
⑦	Lint brush	802424004	
⑧	Tension release clip	797813005	
⑨	Needle threader	202024002	
⑩	Clear view foot	778524007	
⑪	Attachment screw (for fixing optional accessories) * Refer to the instruction of optional accessories.	200217134	
⑫	Accessory box	336401400	
⑬	Foot control*	U.S.A. and Canada	C-1028-1
		U.K.	C-2064-1
		Australia	C-2065-1
		Continental Europe	C-2060-1
⑭	Instructional DVD	778803003	
⑮	Instruction book	778800000	
⑯	Soft cover	795801107	

* The foot control included may differ from the illustration.

GETTING READY TO SEW

Connecting the Machine to the Power Supply

! WARNING:

While in operation, always keep your eyes on the sewing area, and do not touch any moving parts such as the thread take-up lever, loopers, handwheel or needle.

Always turn off the power supply:

- when leaving the machine unattended.
- when attaching or removing parts.
- when cleaning the machine.

Do not place anything on the foot control.

Operating Instructions:

The symbol "O" on a switch indicates the "off" position of the switch.

- 1 Turn off the power switch, and connect the machine plug to the machine socket.
- 2 Connect the power supply plug into the wall outlet.
- 3 Turn on the power switch.
 - 1 Power switch
 - 2 Machine plug
 - 3 Machine socket
 - 4 Power supply plug
 - 5 Wall outlet
 - 6 Foot control

NOTE:

Make sure to use the power supply cable that came with the machine.

Wait for a while until the LED light turns on.

For the U.S.A. and Canada only

- Polarized plug (one blade wider than the other): To reduce the risk of electric shock, this plug is intended to fit in a polarized outlet only one way. If it does not fit fully in the outlet, reverse the plug. If it still does not fit, contact a qualified electrician to install the proper outlet. Do not modify the plug in any way.
- Foot controller Model YC-482J is for use with this sewing machine.

Controlling Sewing Speed

Sewing speed can be varied by the foot control.

The harder you press on the control, the faster the machine runs.

Step on the foot control with the presser foot lifter up, and practice controlling the speed.

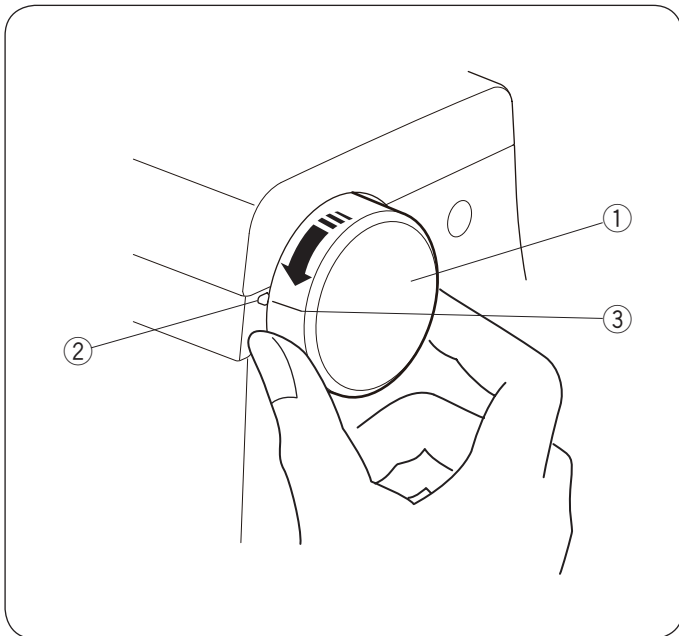

How to Turn the Handwheel

Always turn the handwheel toward you (counterclockwise). Match the mark on the machine with the setting mark on the handwheel when threading needles, turning the fine mode switching lever or raising/lowering the top cover stitch spreader.

- ① Handwheel
- ② Mark
- ③ Setting mark

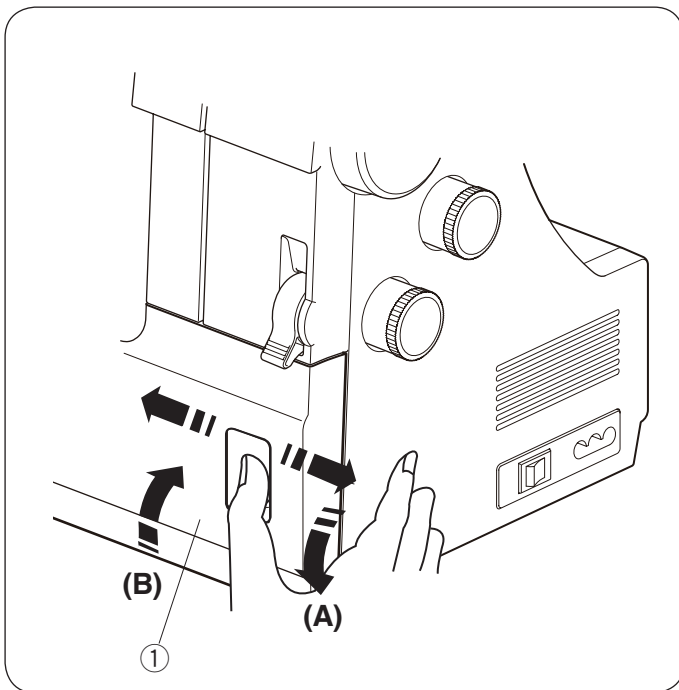

Opening and Closing the Looper Cover

To open: (A)

Hold the looper cover with your thumb and slide it to the right as far as it will go, then pull and open the looper cover toward you.

- ① Looper cover

To close: (B)

Lift the looper cover and push it against the machine. The looper cover snaps into its original position automatically.

NOTE:

Close the looper cover while in use.

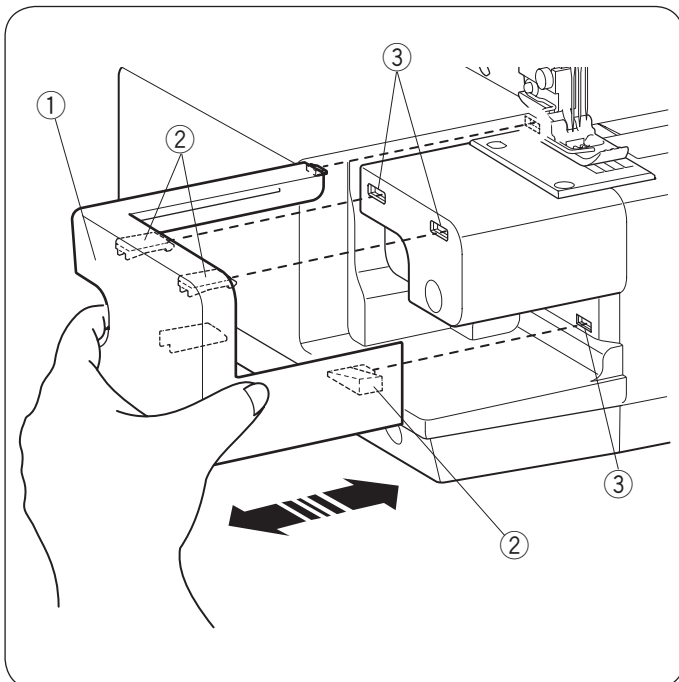

Extension Table

The extension table provides added sewing surface and can be easily removed for free arm sewing (refer to page 40).

Detaching the table:

Pull the table away from the machine.

- ① Extension table

Attaching the table:

Align the pins on the table with the holes in the machine. Push the extension table until it snaps into the machine.

- ② Pin
- ③ Hole

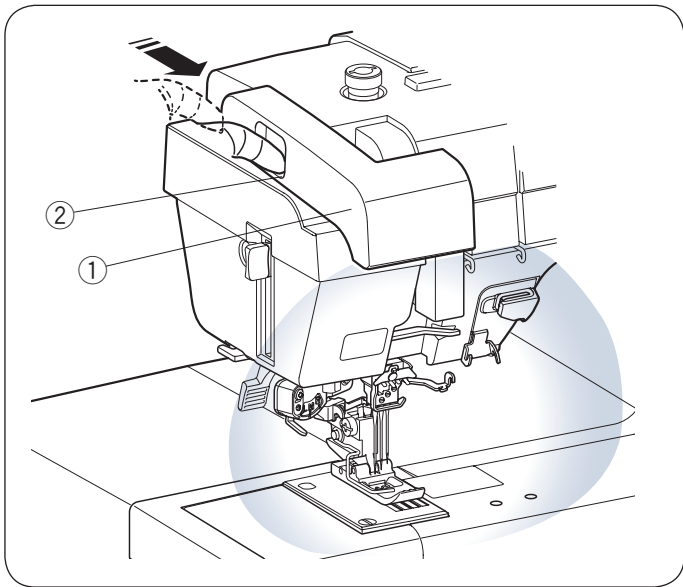

Retractable Sewing Light

In addition to the twin LED lights, the machine is equipped with a retractable light.

Place your finger in the groove and slide the arm towards you. The light will turn on automatically.

- ① Arm
- ② Groove

Push back the arm to turn the light off and store it.

⚠ CAUTION:

Do not hit or exert excessive force on the arm of the retractable sewing light as this may cause damage when it is extended.

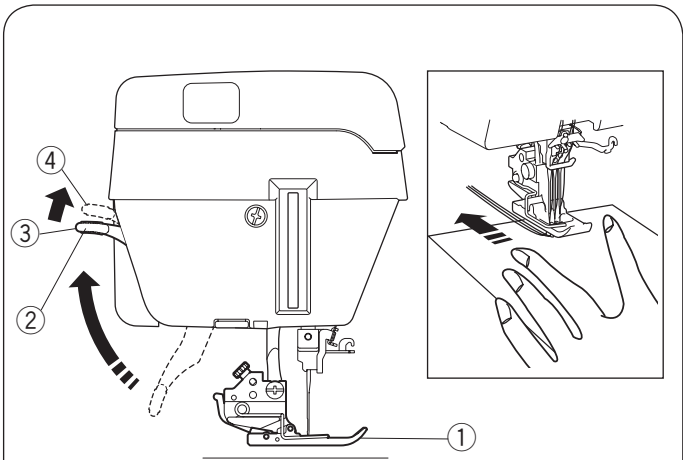

Presser Foot Lifter

The presser foot lifter raises and lowers the presser foot. Raise the presser foot lifter before you thread the machine.

You can raise the foot about 1.5 mm (1/16") higher than the normal up position by exerting more pressure when lifting the presser foot. This allows for changing the needle plate and helps you to place layers of thick fabric.

Always lower the presser foot lifter when you start sewing.

- ① Presser foot
- ② Presser foot lifter
- ③ Normal up position
- ④ Extra lifted position

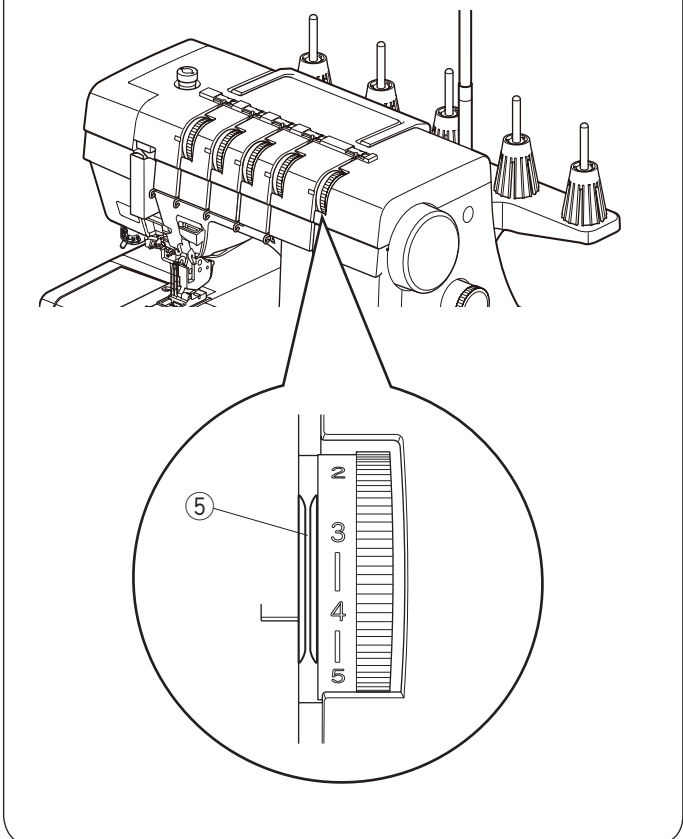

NOTE:

- The left needle may be slightly out from the bottom of the presser foot when inserting heavy fabrics under the presser foot. Be sure to insert the fabric under the presser foot while supporting both sides of the fabric around the presser foot. Same applies when sewing is finished in the middle of heavy weight fabrics.
 - Tension disks open and the thread tension will be released when the presser foot lifter is raised.
- ⑤ Tension disks

Replacing the Presser Foot

CAUTION:

Turn off the power switch when changing the presser foot.

Removing the Presser Foot

Turn off the power switch.

Turn the handwheel toward you to raise the needle to its highest position.

Raise the presser foot lifter.

Press the lever located on the back of the foot holder.

The presser foot will drop off.

- ① Handwheel
- ② Lever
- ③ Foot holder

CAUTION:

Do not push the lever from the top.

Attaching the Presser Foot

Turn off the power switch.

Place the presser foot while lifting the presser foot lifter to the extra lifted position, so that the pin on the foot lies just under the groove of the foot holder (refer to page 6).

Lower the foot holder to lock the foot into place.

Raise the presser foot lifter to check that the presser foot is secure.

- ① Foot holder
- ② Groove
- ③ Pin

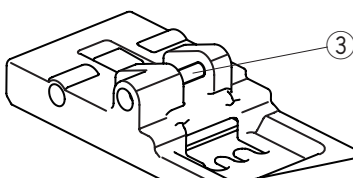
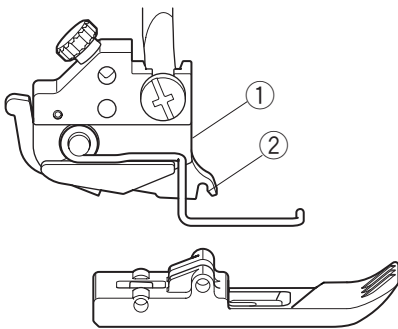
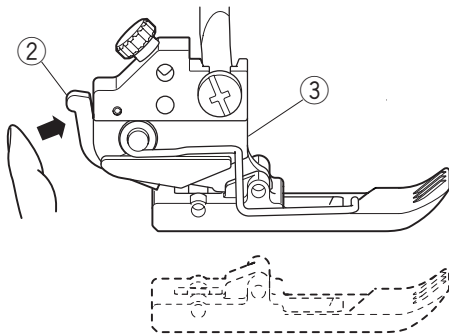
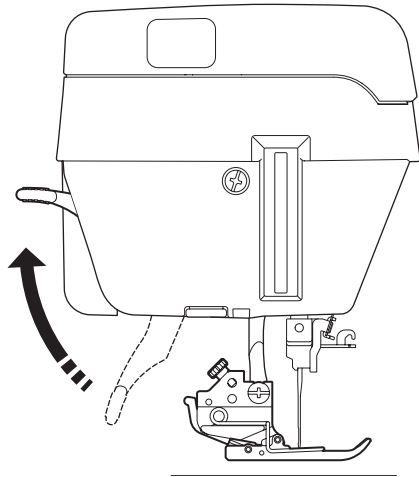
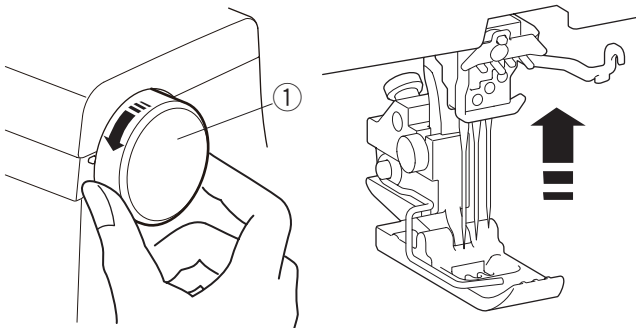

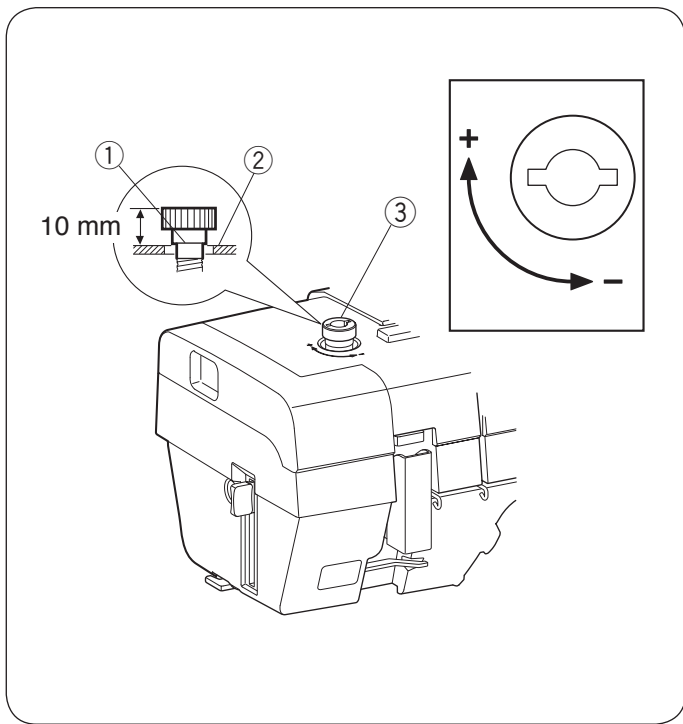

Adjusting the Presser Foot Pressure

It is not necessary to adjust the presser foot pressure for regular sewing.

When sewing heavyweight fabrics, increase the foot pressure by turning the adjusting screw in the direction of “+”.

When sewing lightweight fabrics, decrease the foot pressure by turning the adjusting screw in the direction of “-”.

After sewing, return the adjusting screw to normal position.

For regular sewing, align the line on the screw with the top surface of the machine.

- ① Line
- ② Top surface
- ③ Adjusting screw

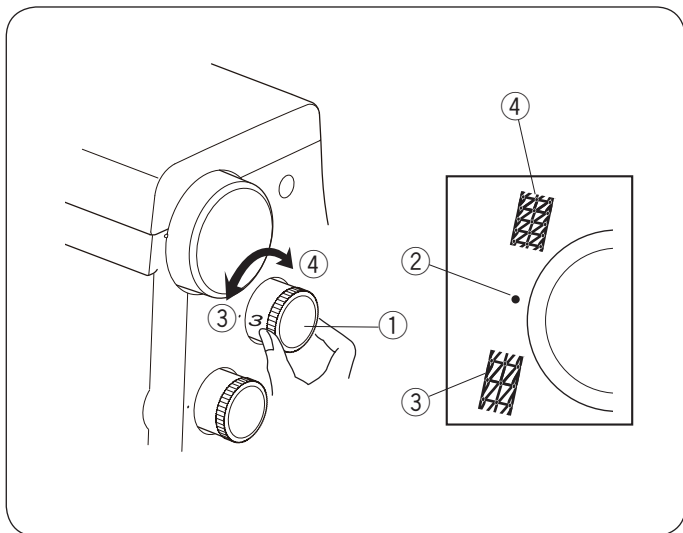

Adjusting the Stitch Length

To adjust the stitch length, turn the stitch length dial.

The larger the number, the longer the stitch length.

The smaller the number, the shorter the stitch length.

• Set the dial at 3 for regular sewing.

- ① Stitch length dial
- ② Setting mark
- ③ To lengthen
- ④ To shorten

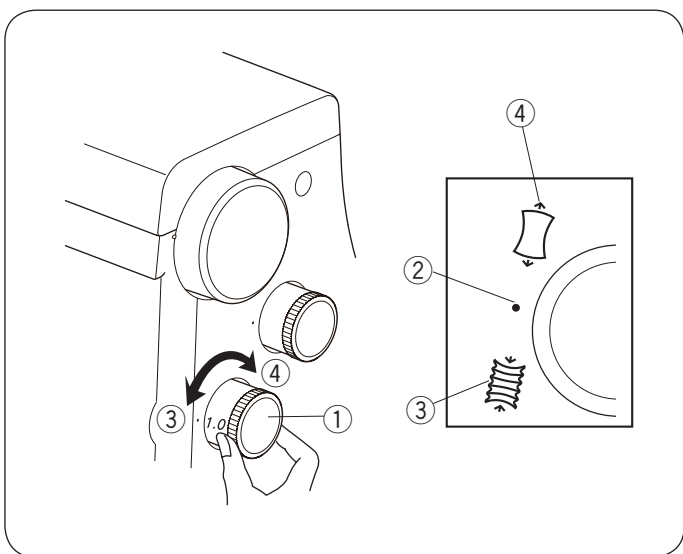

Adjusting the Differential Feed Ratio

The differential feed ratio can be altered by turning the differential feed dial.

The number on the dial indicates the ratio between the main and the sub feed motion.

• Set the dial at 1.0 for regular sewing.

• Set the dial at a lower number when sewing fine fabrics that tend to pucker.

• Set the dial at a higher number when sewing stretch fabrics such as knits, jersey and tricot.

- ① Differential feed dial
- ② Setting mark
- ③ To shrink
- ④ To stretch

Adjusting the Thread Tension

The thread tension can be adjusted by turning the thread tension dials and the fine mode switching lever (refer to page 26 - 33 for thread tension dials).

NOTE:

Match the mark on the machine with the setting mark on the handwheel when turning the fine mode switching lever.

Raise the presser foot lifter before turning the fine mode switching lever.

- ① Handwheel
- ② Mark
- ③ Setting mark

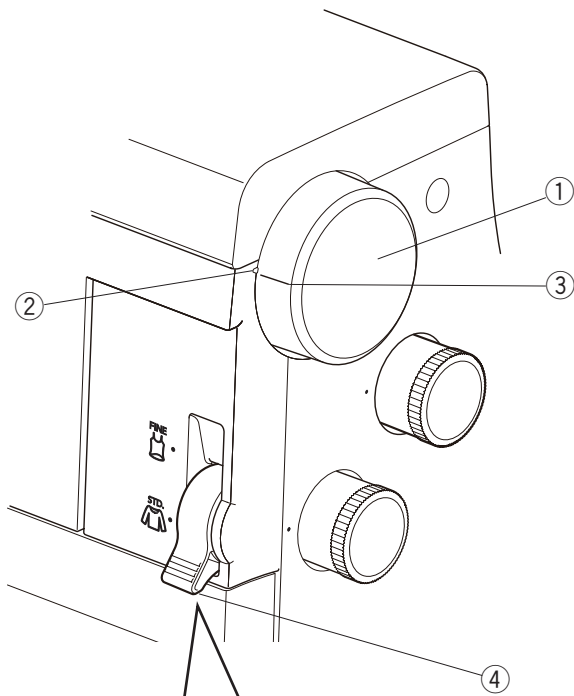

Fine mode switching lever

Turn the fine mode switching lever to STD. for standard to heavy fabrics.

Turn the fine mode switching lever to FINE for fine fabrics.

- ④ Fine mode switching lever
- ⑤ FINE (for fine fabrics)
- ⑥ STD. (for standard/heavy fabrics)

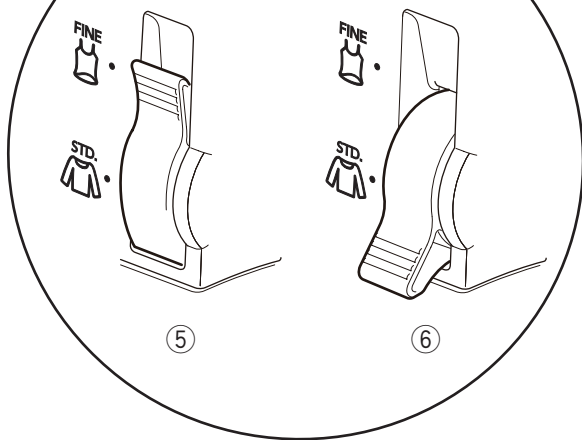

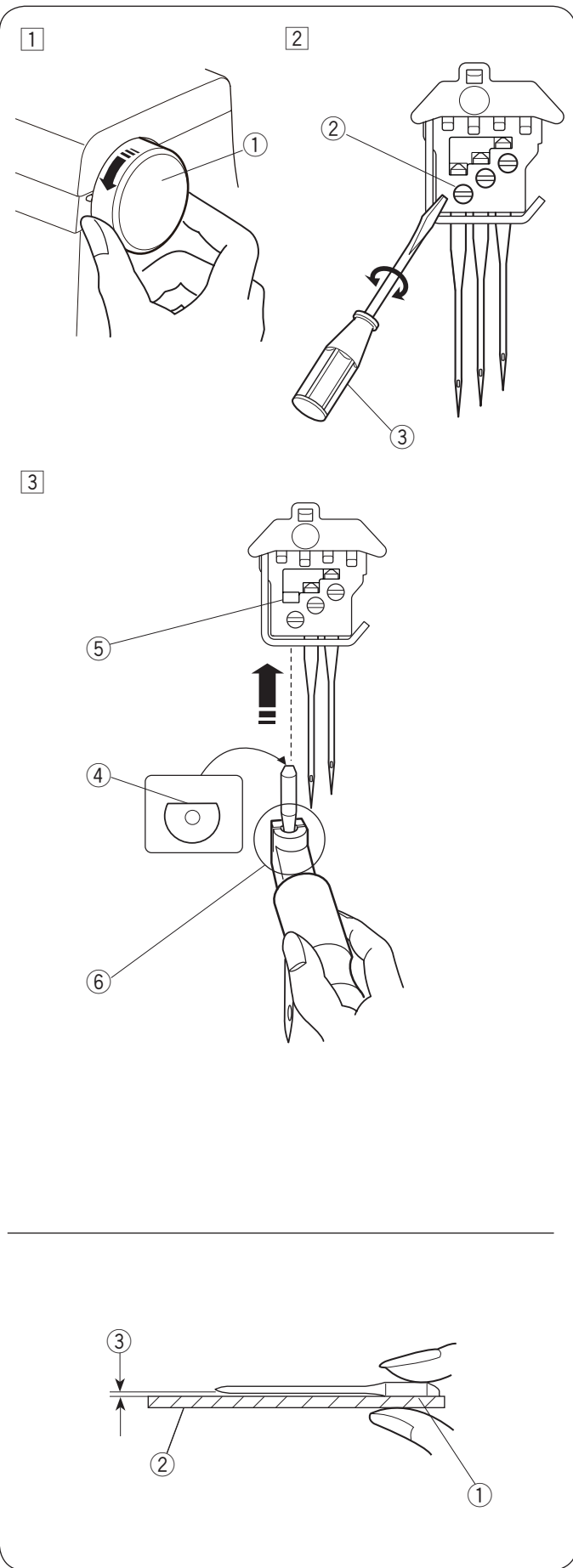

Changing Needle

NOTE:

Use Schmetz EL X 705 80/12 or 90/14 needles.
The machine is installed with Schmetz EL X 705 90/14 needles.

⚠ WARNING:

Turn off the power switch and unplug the machine before changing needles.

- 1 Turn the handwheel toward you to raise the needle to its highest position.
 - 1 Handwheel
- 2 Loosen the needle clamp screw by turning it counterclockwise.
Remove the needle from the needle clamp.
 - 2 Needle clamp screw
 - 3 Small screwdriver
- 3 Insert a needle into the needle clamp with the flat side facing back and push it up against the stopper using the needle holder of the end of the needle threader.
 - 4 Flat side
 - 5 Stopper
 - 6 Needle holder

Tighten the needle clamp screw firmly while supporting the holder in place.

Pull the holder down to remove it.

Checking the needle

To see if the needle is in good condition, place the flat side of the needle onto something flat (needle plate, glass, etc.). The gap between the needle and the flat surface should be consistent. Never use a bent or blunt needle.

- 1 Flat side
- 2 Something flat
- 3 Gap

NOTE:

Never use a bent or blunt needle.

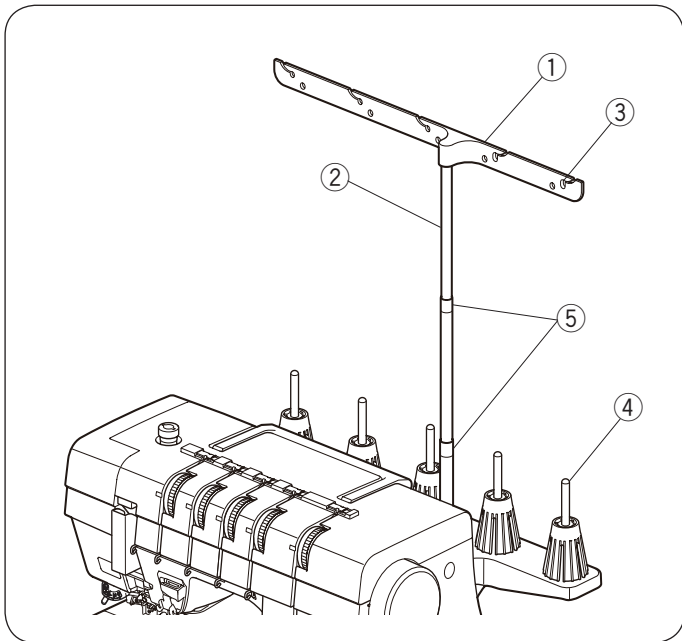

Setting the Thread Guide Bar

Pull the thread guide bar up as far as it will go.

Turn the thread guide post so that the thread guides are right above the spool pins.

- ① Thread guide bar
- ② Thread guide post
- ③ Thread guide
- ④ Spool pin
- ⑤ Stoppers

NOTE:

Be sure to snap both stoppers into places.

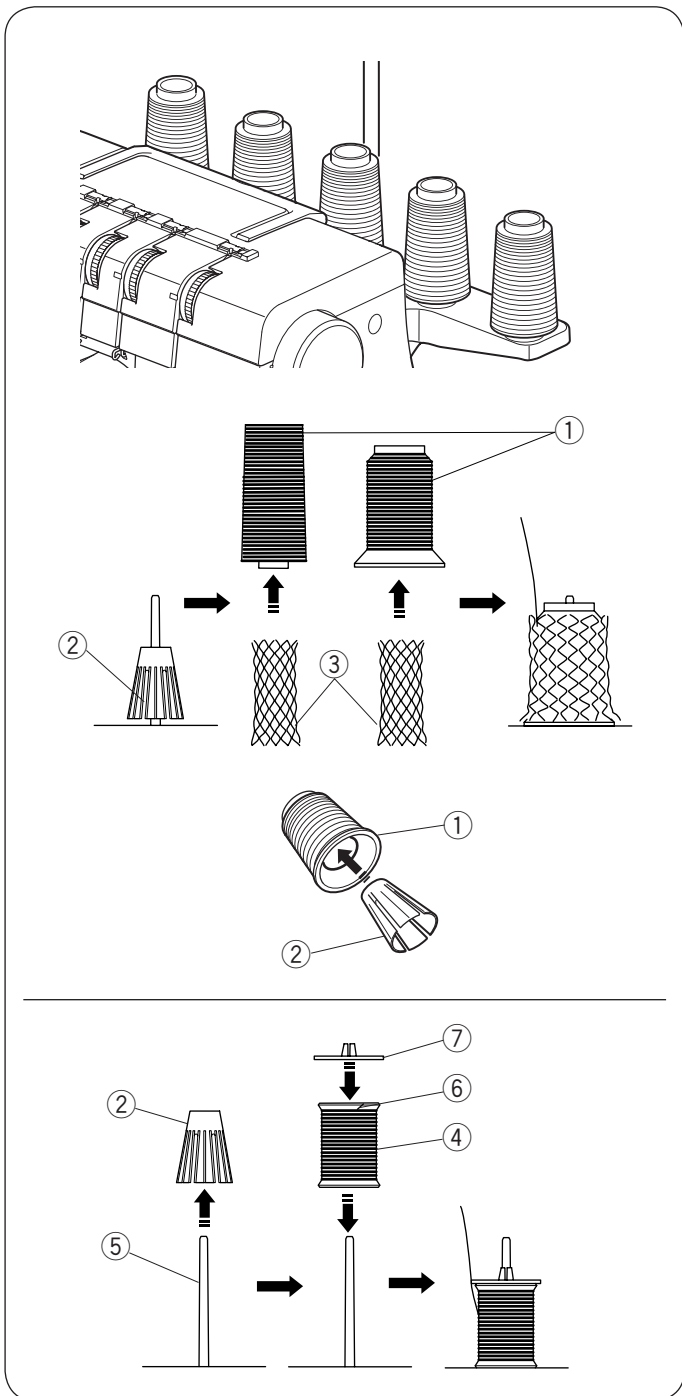

Setting the Spools

You can use two types of spools for this machine.

Spool cones

When using spool cones, attach the spool holders to the spool pins.

If the thread slips down from a spool cone during the threading and/or sewing, put the net over the spool cone as shown to prevent jamming.

- ① Spool cone
- ② Spool holder
- ③ Net

NOTE:

If the spool cone is unstable, insert the spool holder into the spool cone all the way before setting it to the spool pin.

Small spools

When using small spools, remove the spool holders from the spool pins.

- ② Spool holder
- ④ Small spool of thread
- ⑤ Spool pin

Place the spool with its slit side up, and put the spool holder cap on top of it.

- ⑥ Slit
- ⑦ Spool holder cap

Threading the machine

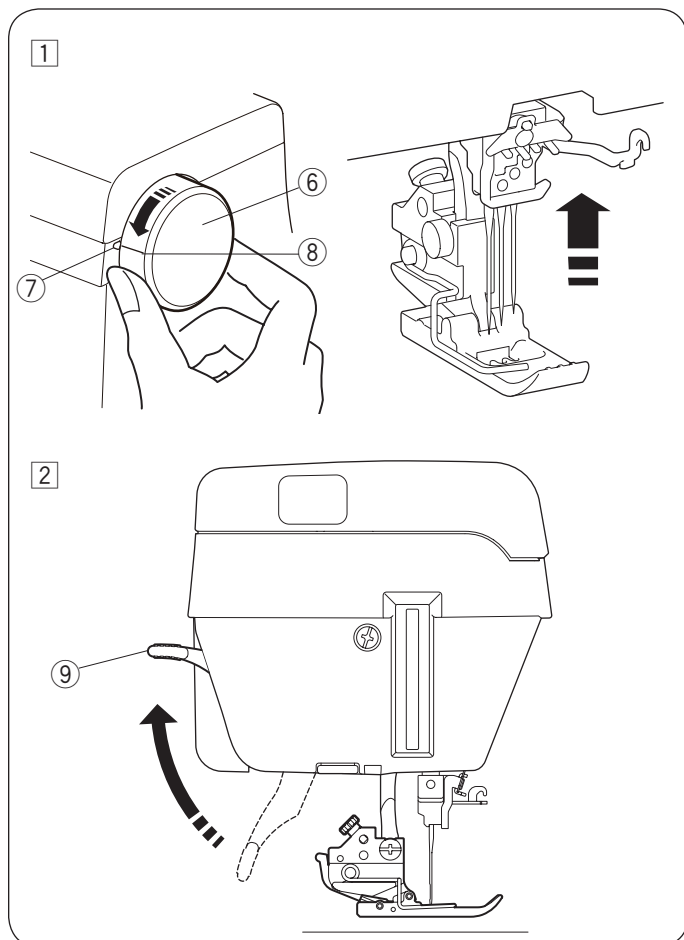
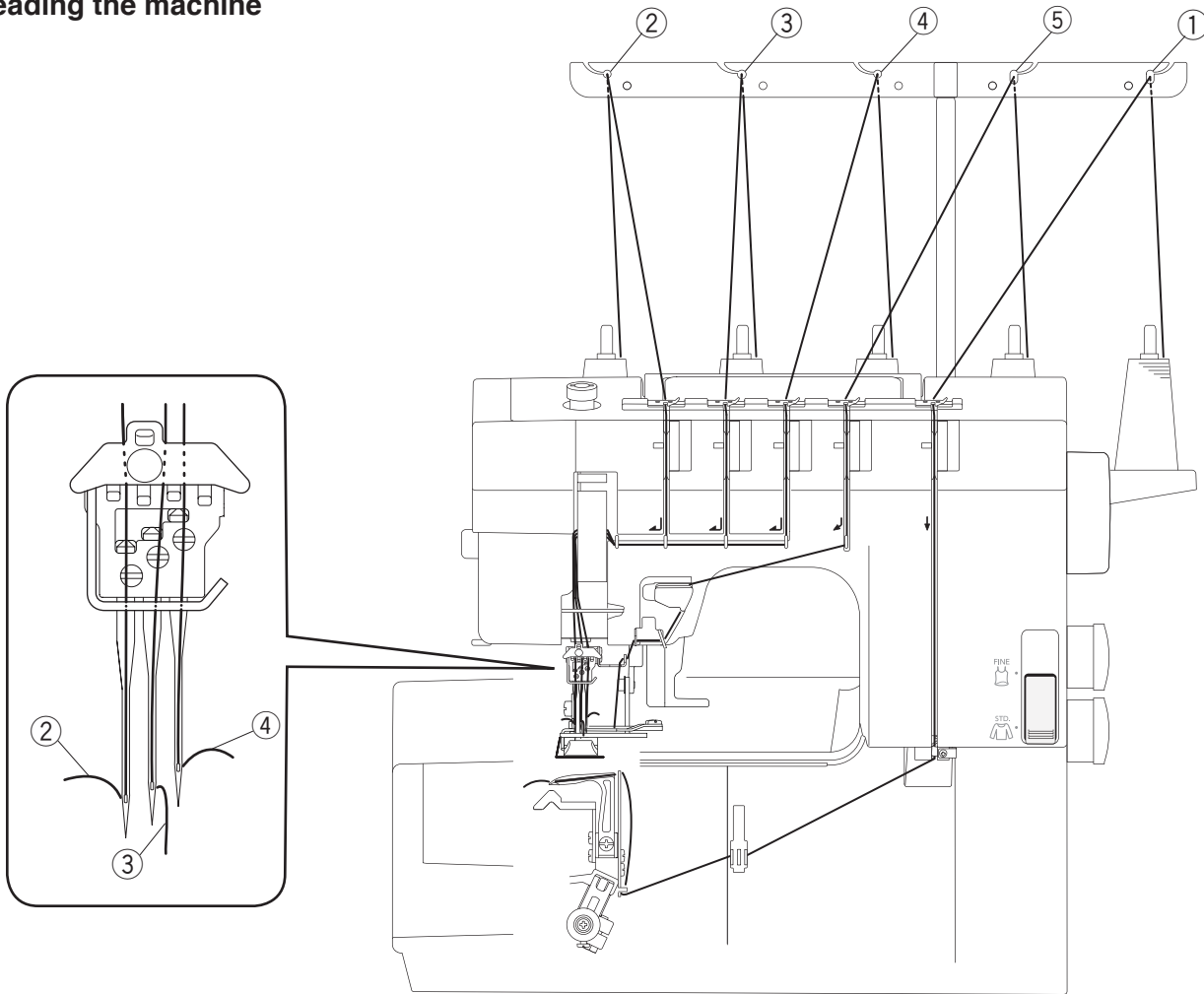

! WARNING:

Turn off the power switch before threading the machine.

Threading preparation

- ① Looper thread
 - ② Left needle thread
 - ③ Center needle thread
 - ④ Right needle thread
 - ⑤ Top cover stitch thread
- ① Raise the needle to the highest position by turning the handwheel toward you to match the mark on the machine with the setting mark on the handwheel.
- ⑥ Handwheel
 - ⑦ Mark
 - ⑧ Setting mark

NOTE:

When threading the machine always raise the presser foot lifter.

- ② Raise the presser foot lifter.
- ⑨ Presser foot lifter

Threading the Loper

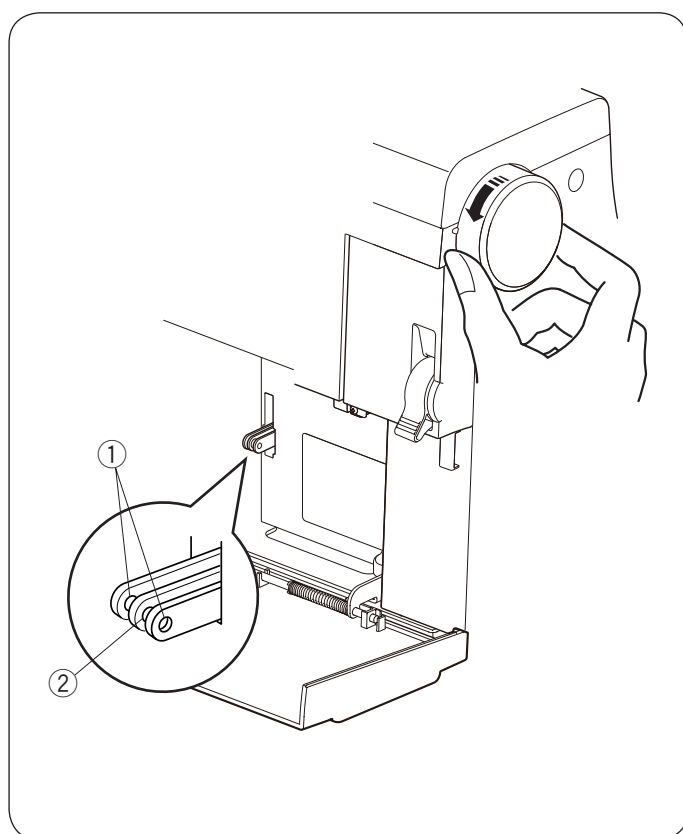
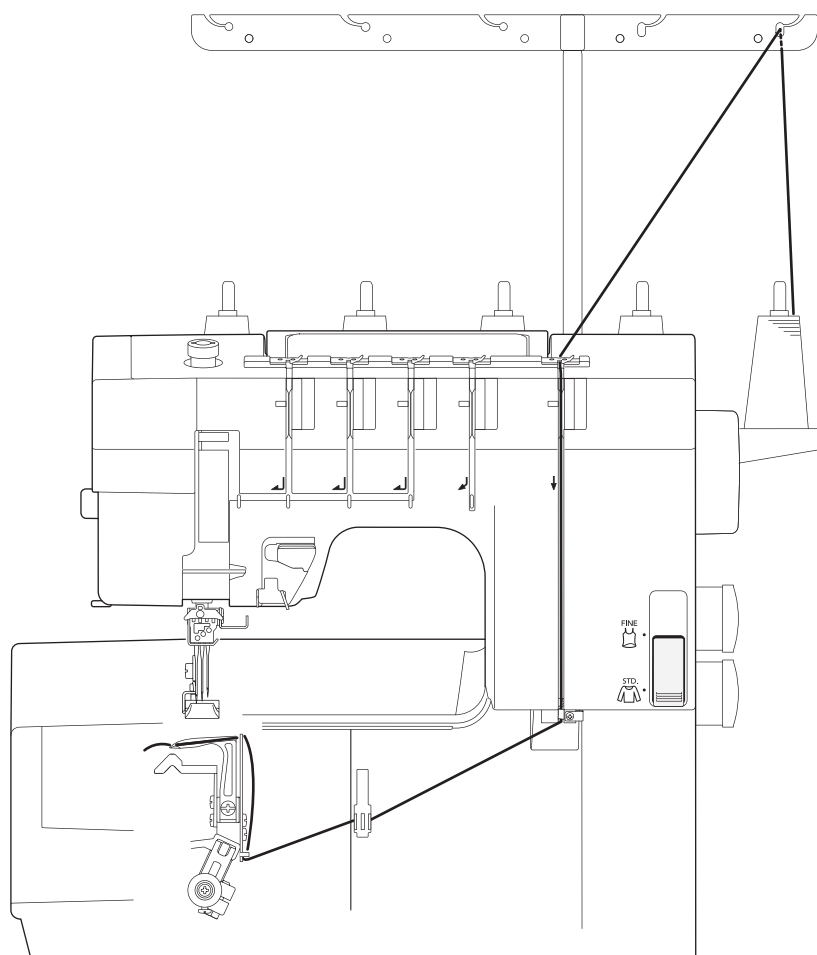

Open the looper cover by sliding it to the right (refer to page 5).

Turn the handwheel toward you to align both guide holes with the eye of the looper thread take-up lever as shown.

- ① Guide holes
- ② Eye of looper thread take-up lever

1

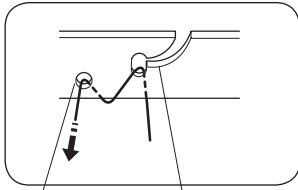
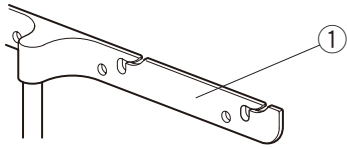

3 2

2

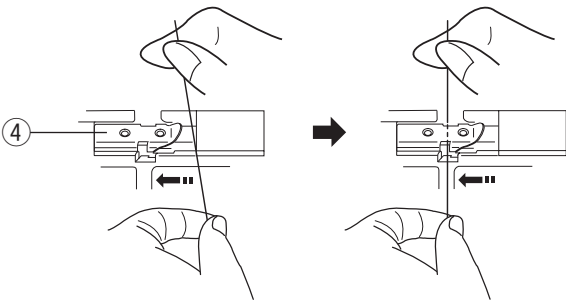

4

3 4

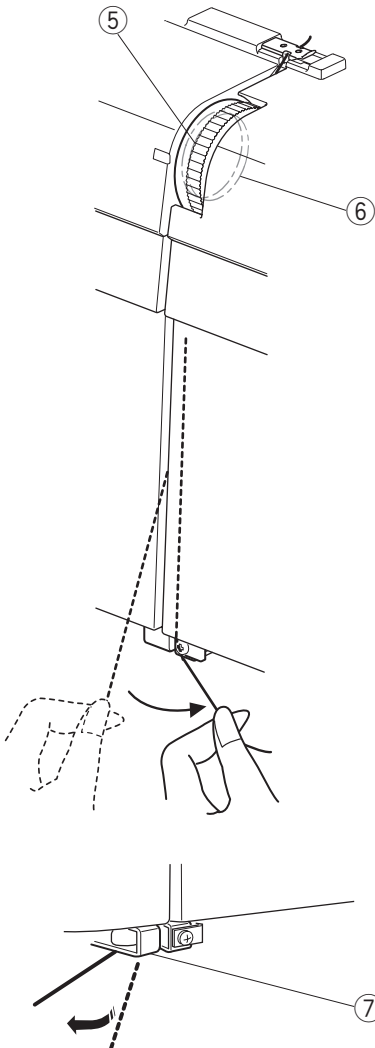

5

6

7

Thread the looper in the following steps:

1 Draw the thread through the right side thread guide from back to front as shown.

1 Thread guide bar

NOTE:

If the thread slips out from the thread guide notch, pass the thread through the thread guide hole again as shown.

2 Notch

3 Hole

2 Slide the thread into the thread guide plate on the machine as shown.

4 Thread guide plate

3 Draw the thread along the slit and pass it through the tension dial.

5 Tension dial

6 Tension disks

NOTE:

Hold the thread at both ends and tug gently to ensure the thread is correctly inserted between the tension disks.

4 Draw the thread down into looper thread guide (A).

7 Looper thread guide (A)

NOTE:

Pull the thread to pass it through looper thread guide (A) until it locks in place while holding the thread at the thread guide plate.

5

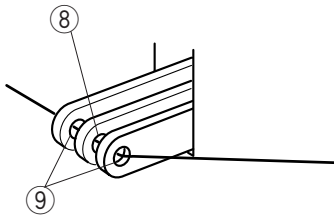

6 7

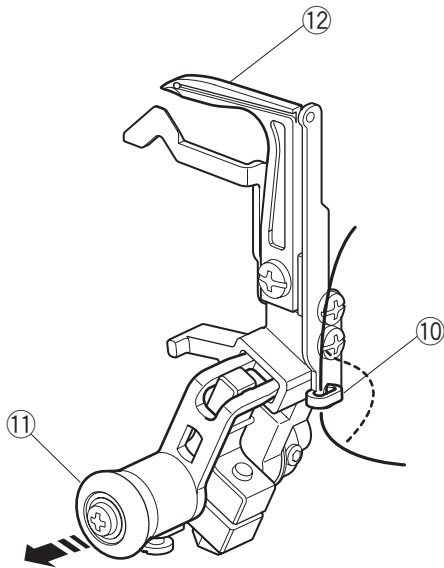

8 9

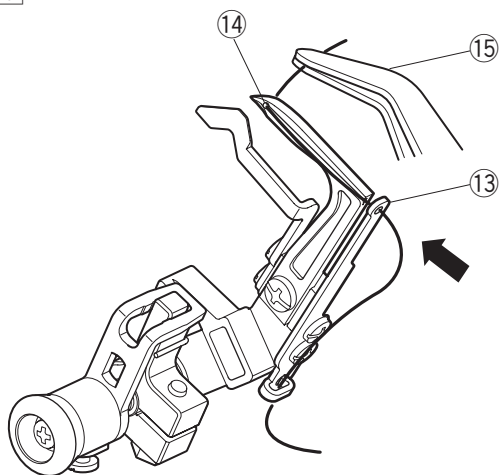

10

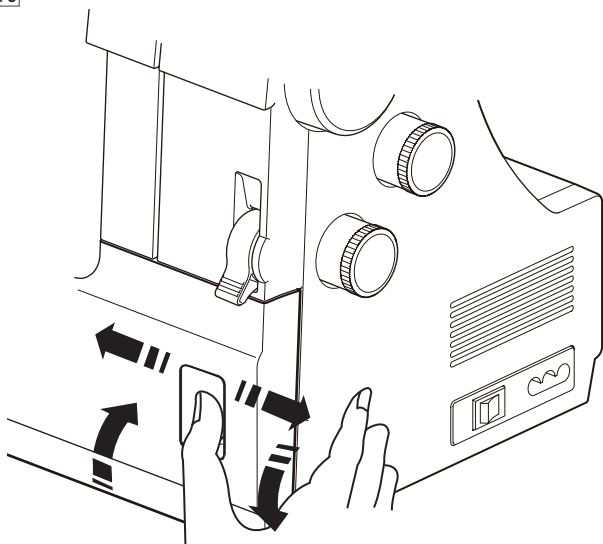

- 5 Turn the handwheel toward you several times to align the eye of the looper take-up lever and both guide holes.

Pass the thread through the eye of the looper take-up lever and both guide holes.

- 8 Looper take-up lever
- 9 Guide holes

- 6 Slip the thread behind looper thread guide (B) from the right.

- 10 Looper thread guide (B)

- 7 Pull the looper release knob and the looper will slant to the right for easy access.

- 11 Looper release knob
- 12 Looper

- 8 Pass the thread through the eye of looper thread guide (C) then through the eye of looper.

Draw the thread end 4" (10 cm) to the back.

- 13 Looper thread guide (C)
- 14 Eye of the looper

NOTE:

You may use a pair of tweezers.

- 15 Tweezers

- 9 Push the looper in the direction of the arrow, back to the original position.

- 10 Close the looper cover.

Threading the Needles

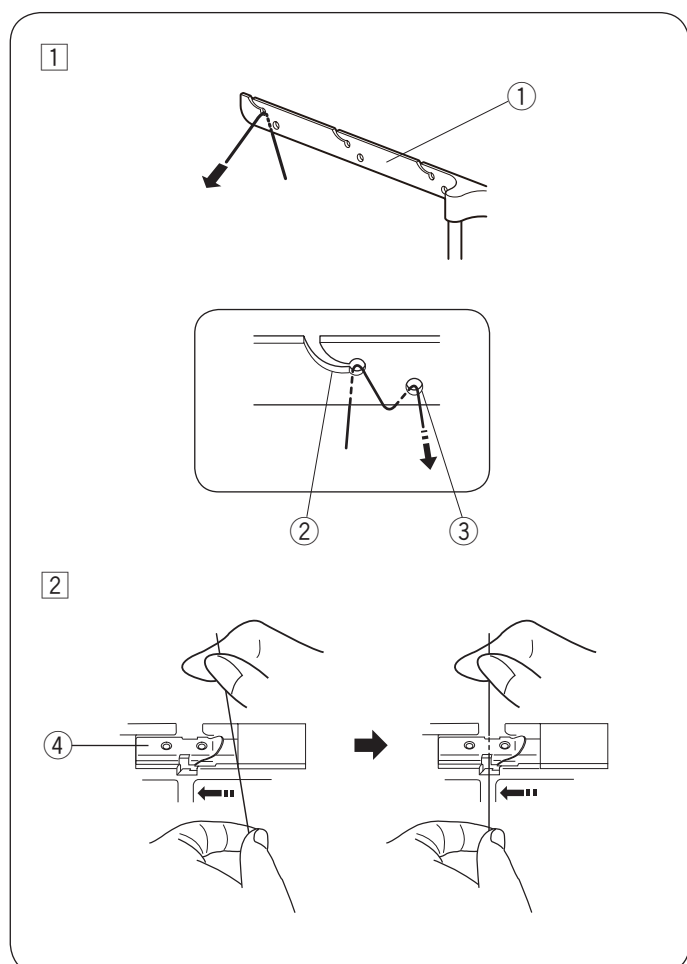
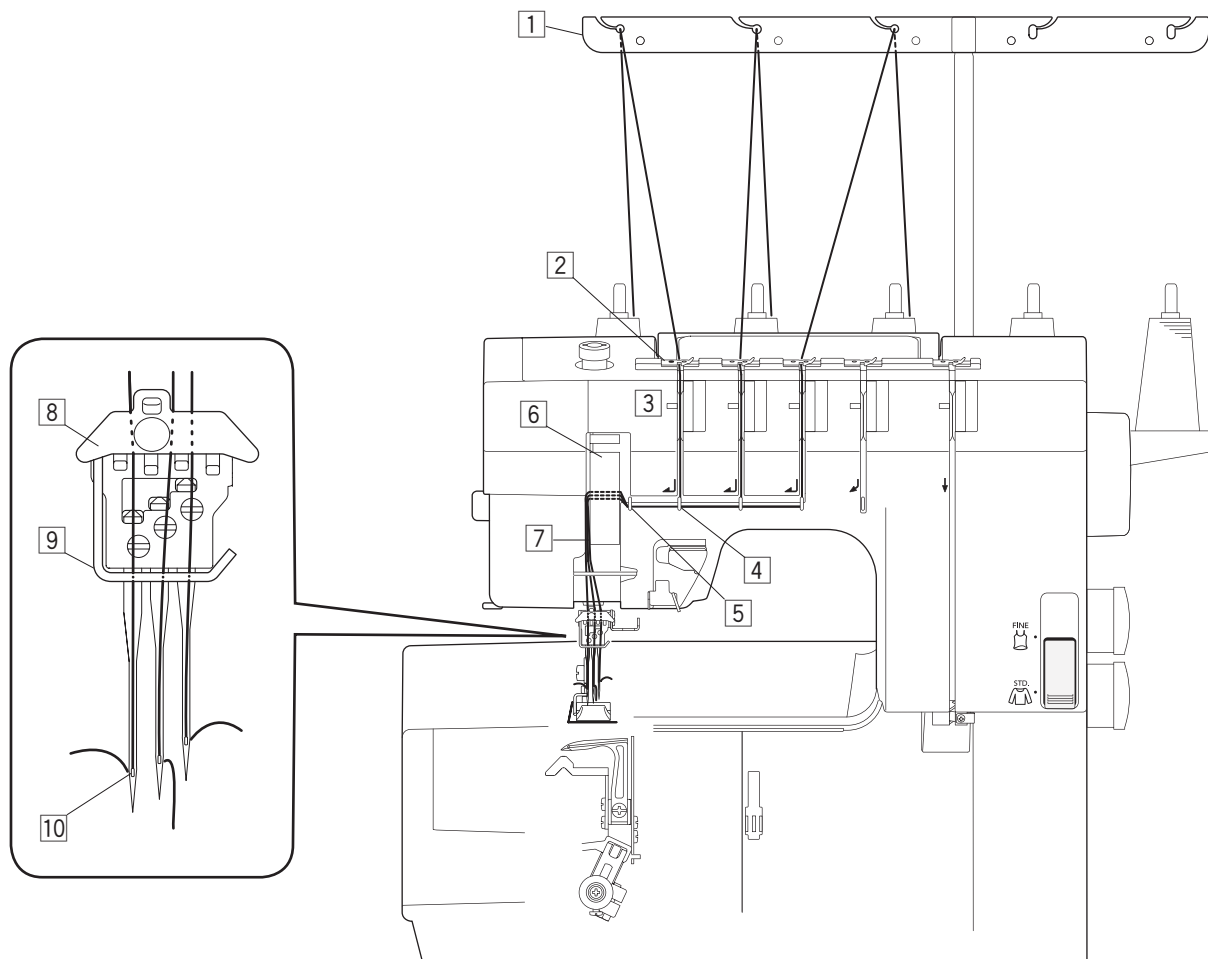

Thread each needle in the following steps:

- 1 Draw the thread through the left side thread guide from back to front as shown.

① Thread guide bar

NOTE:

If the thread slips out from the thread guide notch, pass the thread through the thread guide hole again as shown.

② Notch
③ Hole

- 2 Slide the thread into the thread guide plate on the machine as shown.

④ Thread guide plate

3 4

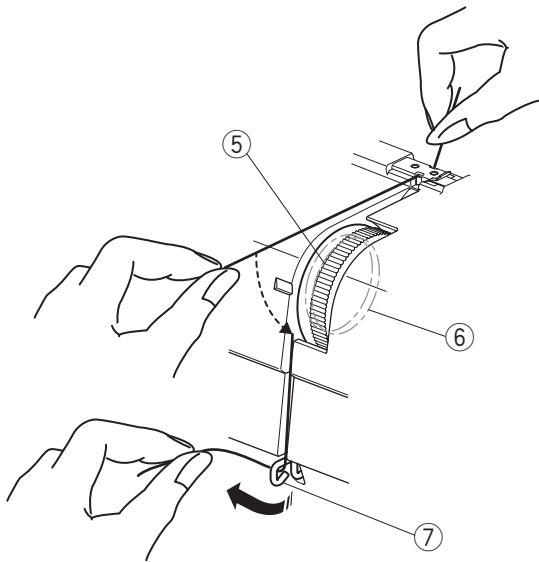

3 Draw the thread along the slit and pass it through the tension dial.

- 5 Tension dial
- 6 Tension disks

NOTE:

Hold the thread at both ends and tug gently to ensure the thread is correctly inserted between the tension disks.

4 Pass the thread through thread guide (A) from the right.

- 7 Thread guide (A)

5 6 7

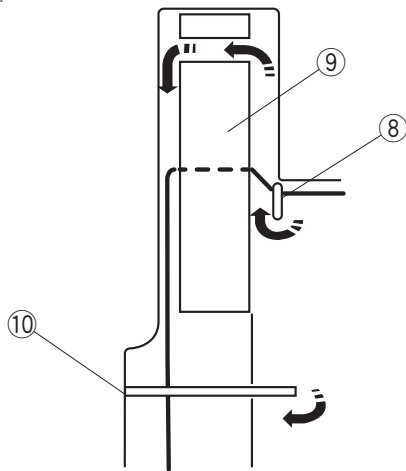

5 Draw the thread to the left and pass it through thread guide (B).

6 Draw the thread up and slip it behind the take-up lever cover.

- 8 Thread guide (B)
- 9 Take-up lever cover

7 Pull the thread down and slip it behind thread guide (C) from the right.

- 10 Thread guide (C)

(A)

8

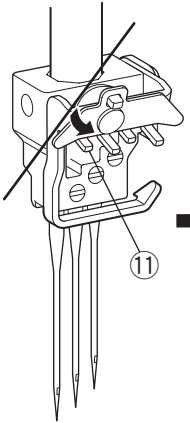

9

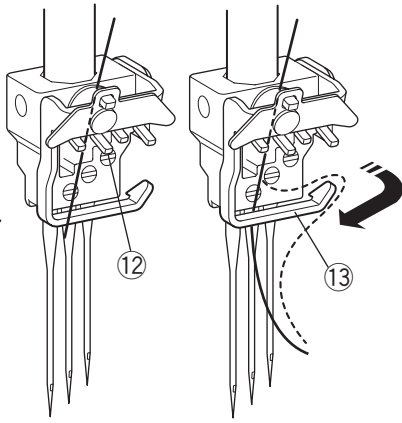

9

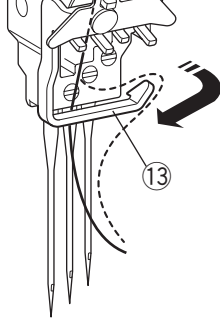

(B)

8

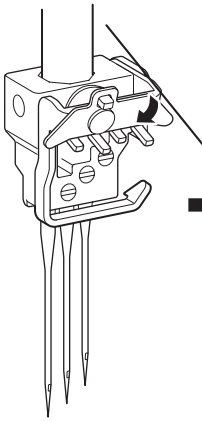

9

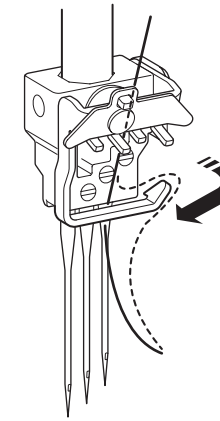
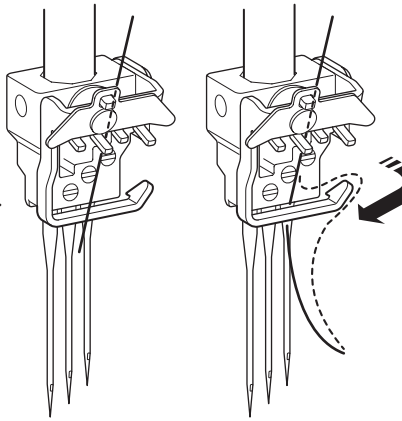

(C)

8

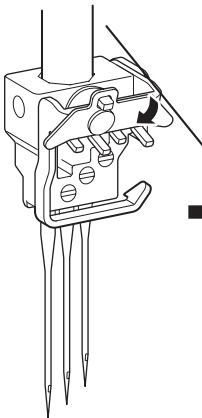

9

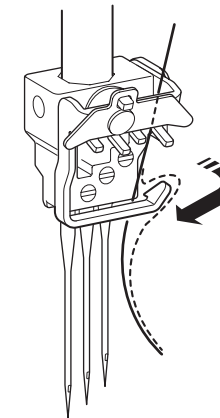
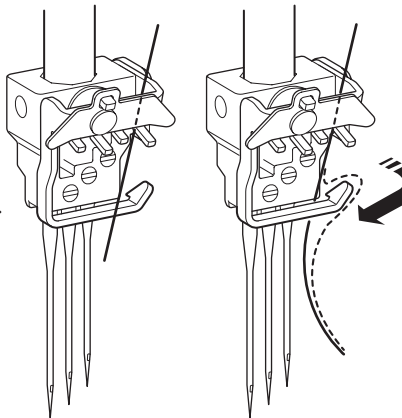

8 Thread each needle as follows:

Left Needle (A):

Pass the thread behind the thread guide plate from the left. Pass the thread between the first and second prongs from the left.

- ① Thread guide plate
- ② Prongs
- ③ Needle bar thread guide

Center needle (B):

Pass the thread behind the thread guide plate from the right. Pass the thread between two inner prongs.

Right needle (C):

Pass the thread behind the thread guide plate from the right. Pass the thread between the first and second prongs from the right.

9 Slip all the threads behind the needle bar thread guide from the right.

10 Thread each needle with the threader (refer to "Built-in Needle Threader" on pages 19-20).

1

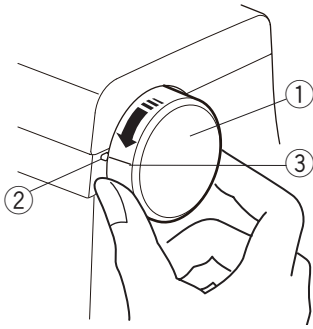

2

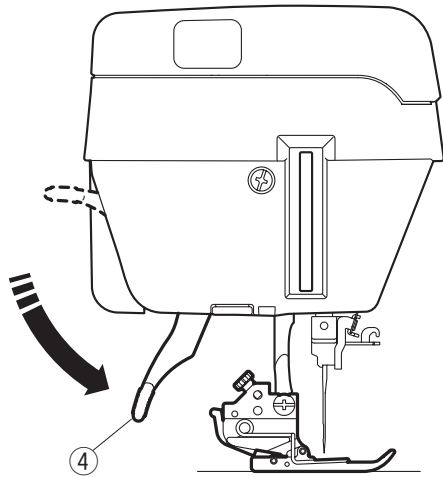

3

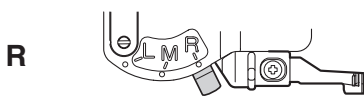
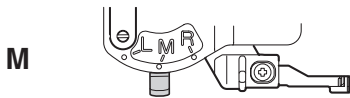
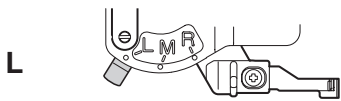
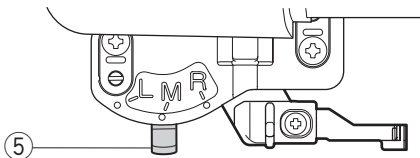

Built-in Needle Threader

Thread the needles with the built-in needle threader.

CAUTION:

Turn off the power switch before threading the machine.

Make sure the top cover stitch spreader is stored to the machine when using the built-in needle threader (refer to page 38).

NOTE:

Do not use #30 or thicker threads.

1 Turn the handwheel toward you to match the mark on the machine with the setting mark on the handwheel.

- ① Handwheel
- ② Mark
- ③ Setting mark

2 Lower the presser foot lifter.

- ④ Presser foot lifter

3 **L:** Set the needle threader switch lever to L when threading the left needle.

M: Set the needle threader switch lever to M when threading the center needle.

R: Set the needle threader switch lever to R when threading the right needle.

- ⑤ Needle threader switch lever

4

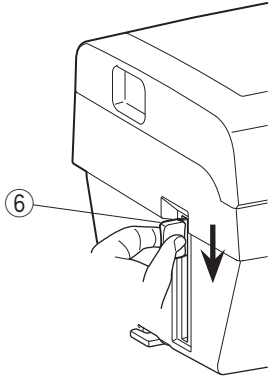

4 Pull down the needle threader lever as far as it will go.

6 Needle threader lever

5

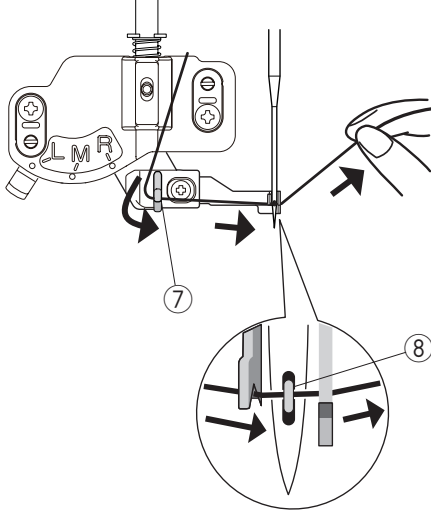

5 Draw the thread along the guide on the needle threader lever from the left and under the hook.

7 Guide

8 Hook

6

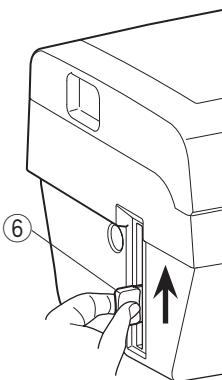

6 Slowly raise the threader lever so that a loop of the thread is pulled up through the needle.

6 Needle threader lever

9 Loop

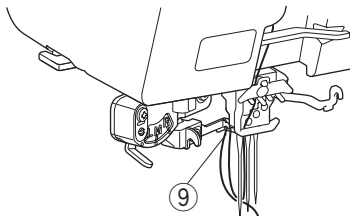

7

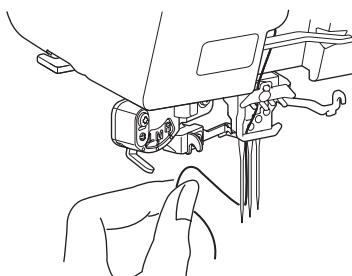

7 Pull the thread loop and draw out the thread end to the rear through the needle eye.

Handy Needle Threader

1

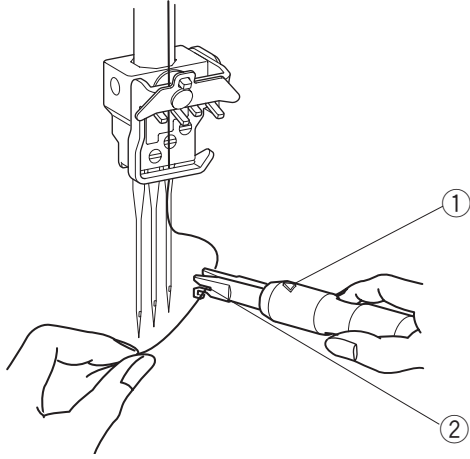

- 1 Hold the grip of the threader with the triangle mark up. Insert the thread into the slit of the Y-shaped notch.

- ① Triangle mark
- ② Y-shaped notch

2 3

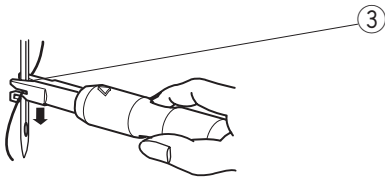

- 2 Place the V-shaped notch over the needle just above the needle eye.

- 3 Slide the threader down along the needle while pushing it against the needle, until the threader pin enters into the needle eye.

- ③ V-shaped notch

4

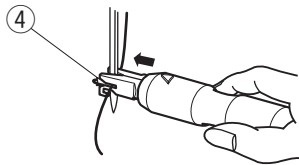

- 4 Push the threader and the thread will go through the needle eye.

- ④ Threader pin

5

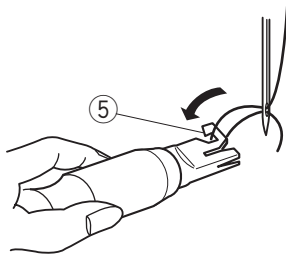

- 5 Remove the threader from the needle. Then pick up the loop of the thread with the hook. Pull the thread end out to the back.

- ⑤ Hook

Threading the Top Cover Stitch Guides and Spreader

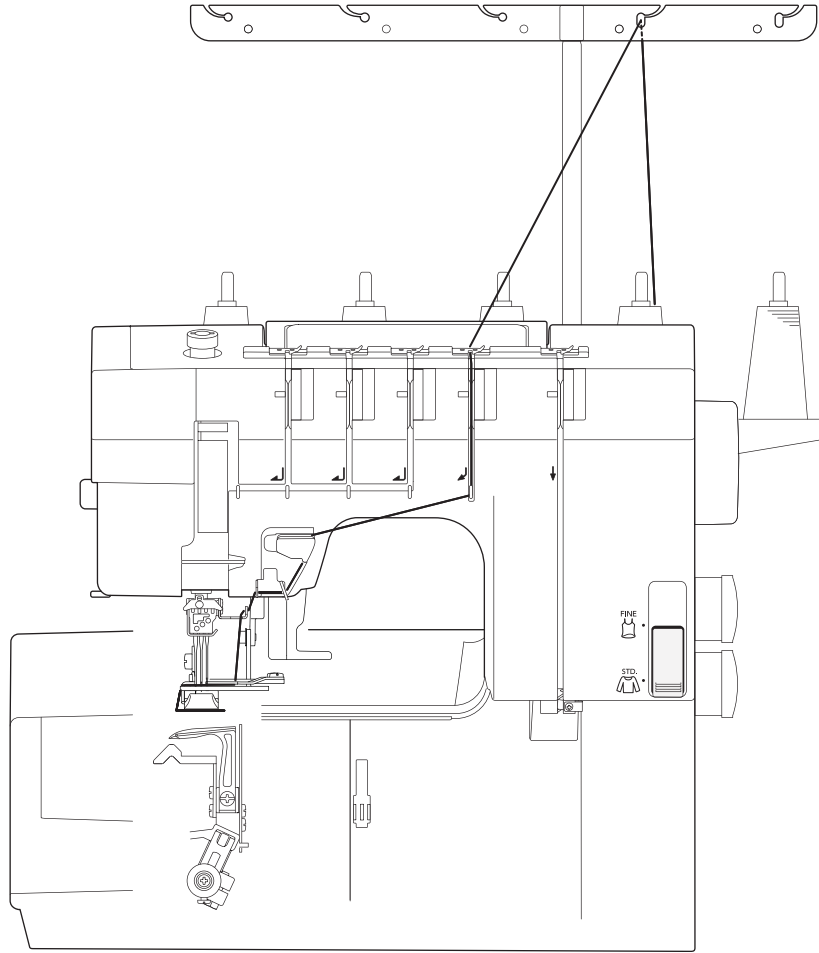

Threading preparation

NOTE:

Raise the top cover stitch spreader when using the built-in needle threader.

- 1 Raise the needle to the highest position by turning the handwheel toward you to match the mark on the machine with the setting mark on the handwheel.

- ① Handwheel
- ② Mark
- ③ Setting mark

- 2 Raise the presser foot lifter.

- ④ Presser foot lifter

- 3 Turn the fine mode switching lever to STD. to sew the top cover stitch.

- ⑤ Fine mode switching lever

- 4 Insert a piece of scrap fabric.

Lower the presser foot lifter and sew 3 to 5 cover stitches.

Raise the needle to the highest position by turning the handwheel toward you to match the mark on the machine with the setting mark on the handwheel.

Raise the presser foot lifter.

Lower the top cover stitch lever to set the top cover stitch spreader.

- ⑥ Top cover stitch lever
- ⑦ Top cover stitch spreader

1

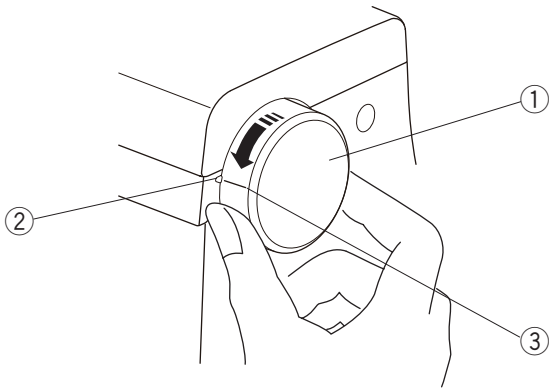

2

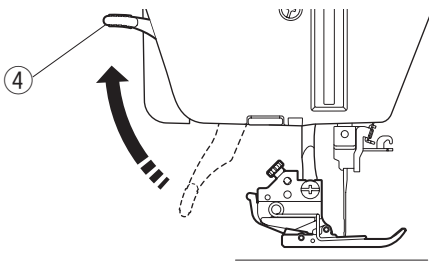

3

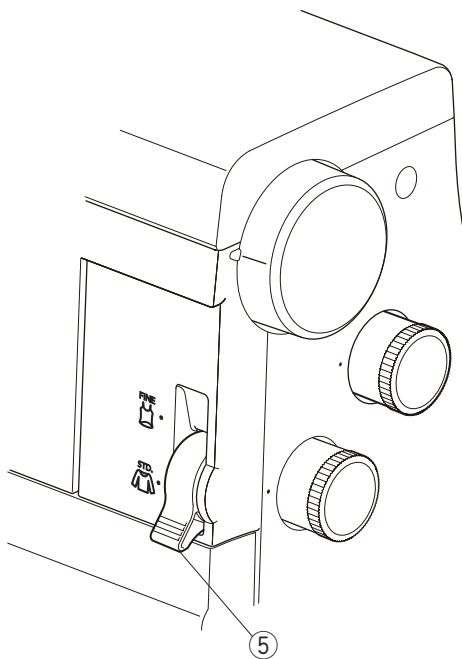

4

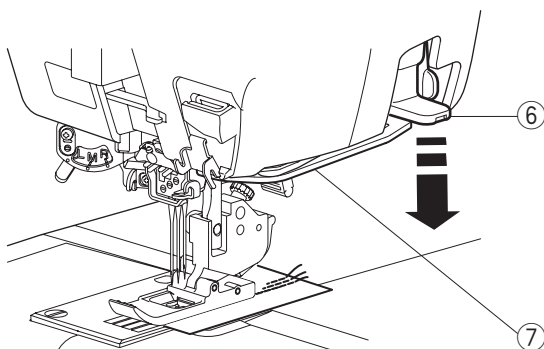

1

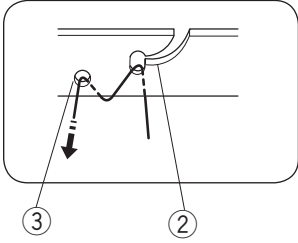
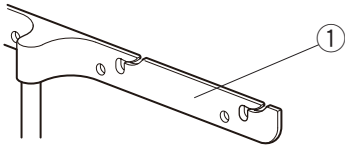

2

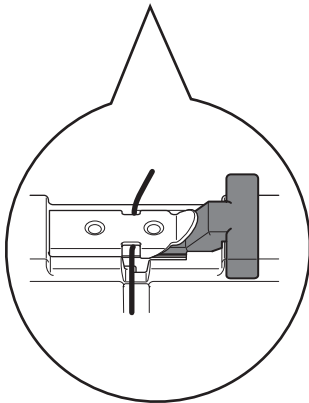
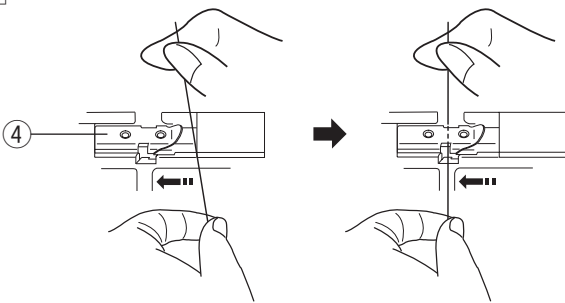

3 4

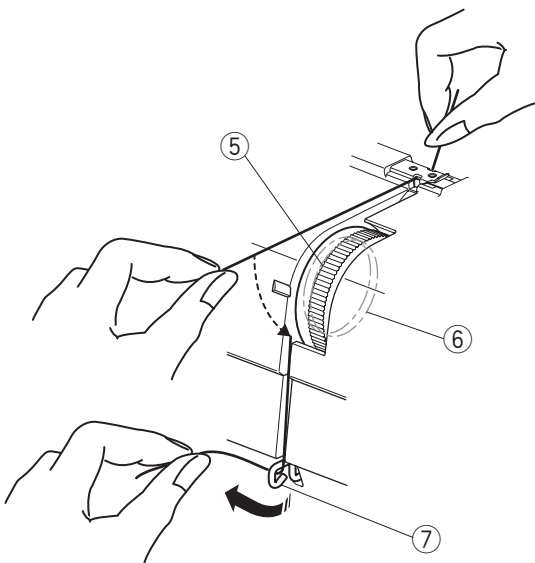

Thread the top cover stitch thread in the following steps:

1 Draw the thread through the right side thread guide from back to front as shown.

① Thread guide bar

NOTE:

If the thread slips out from the thread guide notch, pass the thread through the thread guide hole again as shown.

② Notch

③ Hole

2 Slide the thread into the thread guide plate on the machine as shown.

④ Thread guide plate

NOTE:

When using thick threads, use the tension release clip. Place the tension release clip into the thread guide plate.

3 Draw the thread along the slit and pass it through the tension dial.

⑤ Tension dial

⑥ Tension disks

NOTE:

Hold the thread at both ends and tug gently to ensure the thread is correctly inserted between the tension disks.

4 Pass the thread through thread guide (A) from the right.

⑦ Top cover stitch thread guide (A)

5

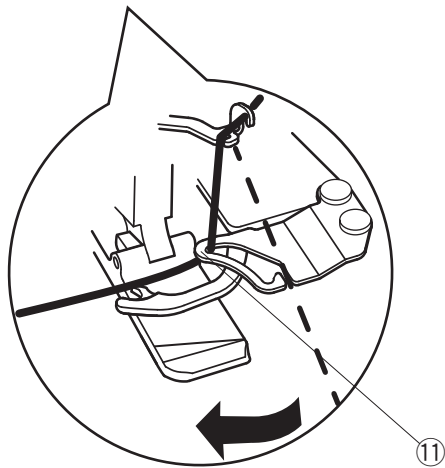
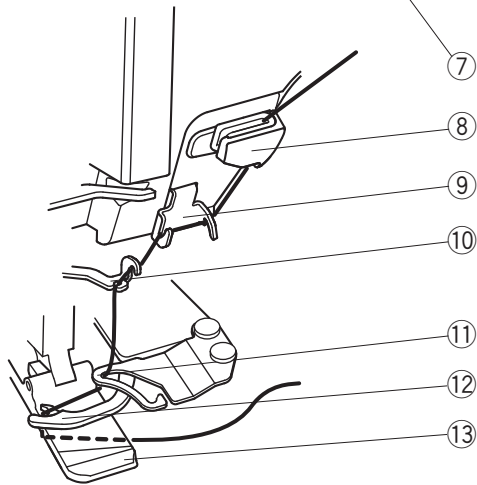
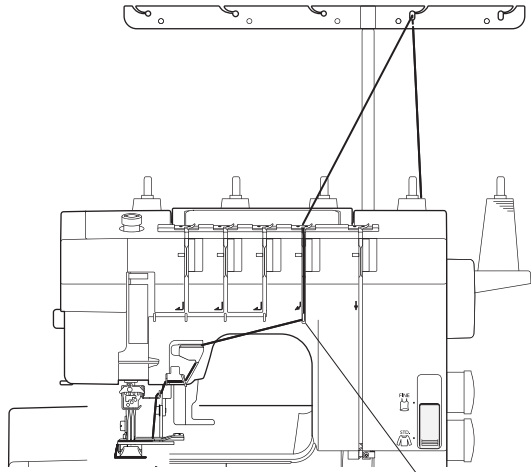

5] Thread the top cover stitch thread in order as shown.

NOTE:

Do not push the top cover stitch thread guide (E) to the right while threading.

- ⑦ Top cover stitch thread guide (A)
- ⑧ Top cover stitch thread guide (B)
- ⑨ Top cover stitch thread guide (C)
- ⑩ Top cover stitch thread guide (D)
- ⑪ Top cover stitch thread guide (E)
- ⑫ Top cover stitch spreader

Draw the top cover stitch thread under the presser foot diagonally as shown and draw 4" (10 cm) of the thread.

- ⑬ Presser foot

Lower the presser foot lifter.

Refer to "Beginning of the seam for top cover stitch" on page 38 for starting to sew the top cover stitch.

NOTE:

Hold the thread at both ends and tug gently to ensure the thread is correctly inserted to the top cover stitch thread guide (E).

- ⑪ Top cover stitch thread guide (E)

STITCH TYPES AND TENSION SETTINGS

Type of Fabric		Needle Size	Type of Thread
Fine	Fine Knits Fine Jersey	80/12 or 90/14	#60-90 Spun
Standard to Heavy	Jersey Fleece	80/12 or 90/14	#60 Spun

NOTE:

- The machine is installed with Schmetz EL X 705 90/14 needles.
- Top cover stitches cannot be sewn with the binder foot (optional).

Top Cover Stitch

This stitch can be sewn with two to three needles and five/four threads.

This stitch forms two or three parallel rows of the straight stitch on the right side with top cover stitch, ideal for hemming, attaching elastics, decorative stitches, etc.

There are three types of top cover stitch:

- Triple top cover stitch
- Top cover stitch: Narrow 3 mm (right)
- Top cover stitch: Wide 6 mm

1 Triple top cover stitch

The triple top cover stitch is sewn with all three needles.

This stitch forms three parallel rows of the straight stitch and top cover stitch on the right side, ideal for hemming, attaching elastics, decorative stitches, etc.

- 1 Left needle
- 2 Center needle
- 3 Right needle

2 Top cover stitch: Narrow 3 mm (right)

Remove the left needle (refer to page 10).

Thread the looper, right and center needles.

- 2 Center needle
- 3 Right needle

NOTE:

Tighten the needle clamp screw that is not being used to prevent losing the screw.

3 Top cover stitch: Wide 6 mm

Remove the center needle (refer to page 10).

Thread the looper, right and left needles.

- 1 Left needle
- 3 Right needle

NOTE:

Tighten the needle clamp screw that is not being used to prevent losing the screw.

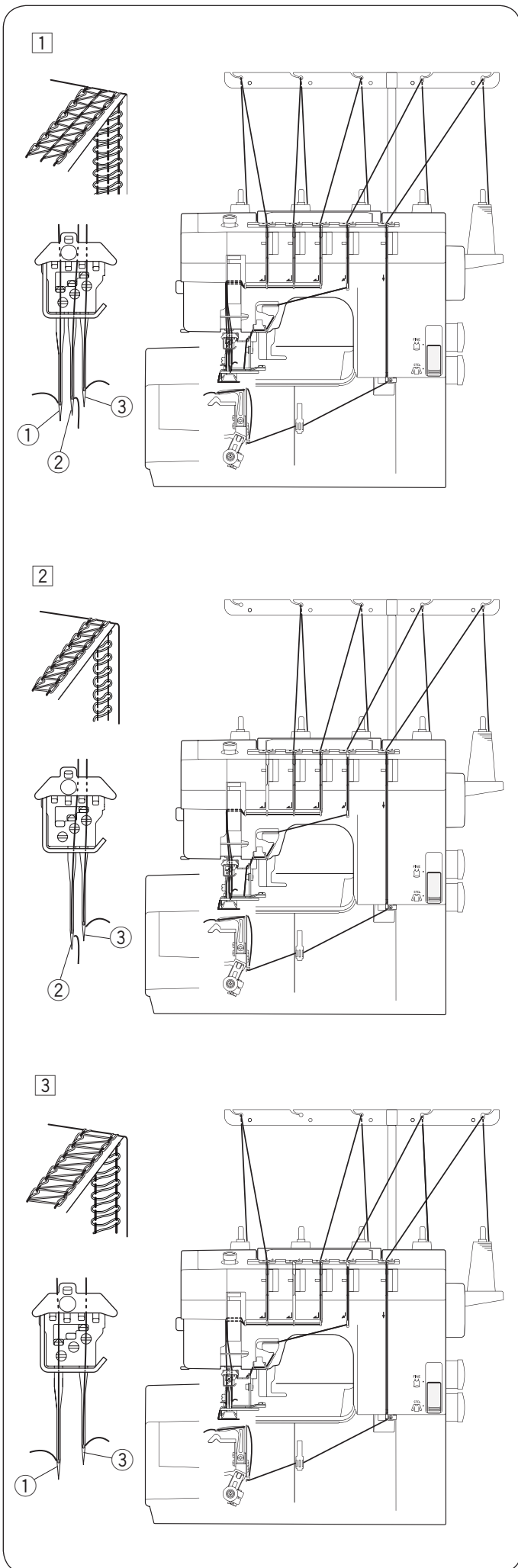

1 2

[1]

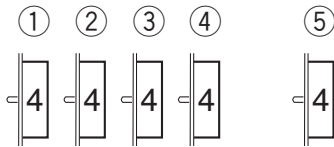

[2]

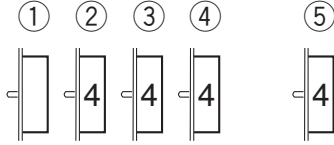

[3]

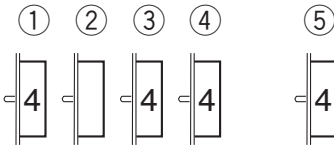

Balancing the thread tension

1 Set the tension dials as follows:

[1] For Triple top cover stitch

① Left needle thread tension dial:	4
② Center needle thread tension dial:	4
③ Right needle thread tension dial:	4
④ Top cover stitch thread tension dial:	4
⑤ Looper thread tension dial:	4

[2] For Narrow 3 mm (right)

① Left needle thread tension dial:	-
② Center needle thread tension dial:	4
③ Right needle thread tension dial:	4
④ Top cover stitch thread tension dial:	4
⑤ Looper thread tension dial:	4

[3] For Wide 6 mm

① Left needle thread tension dial:	4
② Center needle thread tension dial:	-
③ Right needle thread tension dial:	4
④ Top cover stitch thread tension dial:	4
⑤ Looper thread tension dial:	4

2 Check the tension balance by test stitching on the same fabric and threads as actual garment.

Fine-tune the tension as necessary.

Balanced tension

The rows of stitches on the right side of the fabric are straight and even. The looper thread forms the dual rows of squares with diagonals.

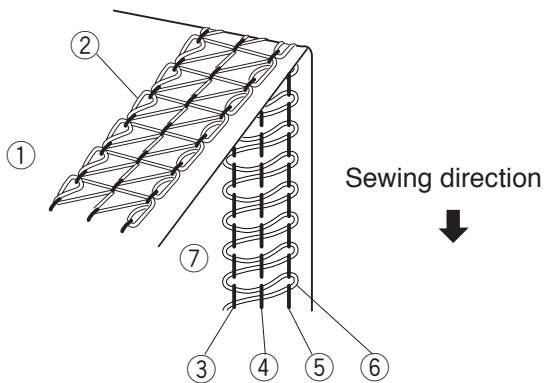

- ① Wrong side of the fabric
- ② Looper thread
- ③ Left needle thread
- ④ Center needle thread
- ⑤ Right needle thread
- ⑥ Top cover stitch thread
- ⑦ Right side of the fabric

Adjusting the needle thread tension

(A) If the needle thread tension is too loose:

Tighten the needle thread tension, and/or loosen the top cover thread tension to correct it.

(B) If the needle thread tension is too tight:

Loosen the needle thread tension, and/or tighten the top cover thread tension to correct it.

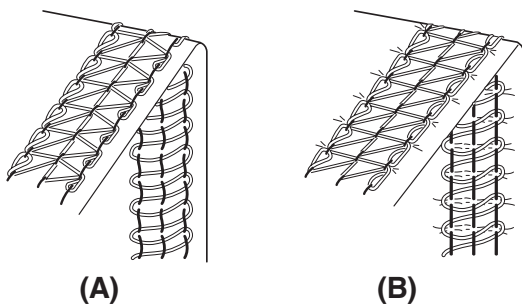

Adjusting the looper thread tension

(A) If the looper thread tension is too loose:

Tighten the looper thread tension, and/or loosen the needle thread tension and the top cover thread tension to correct it.

(B) If the looper thread tension is too tight:

Loosen the looper thread tension, and/or tighten the needle thread tension and the top cover thread tension to correct it.

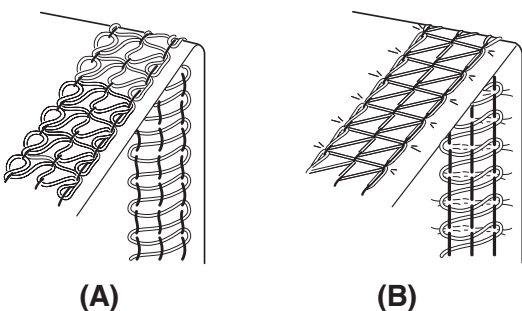

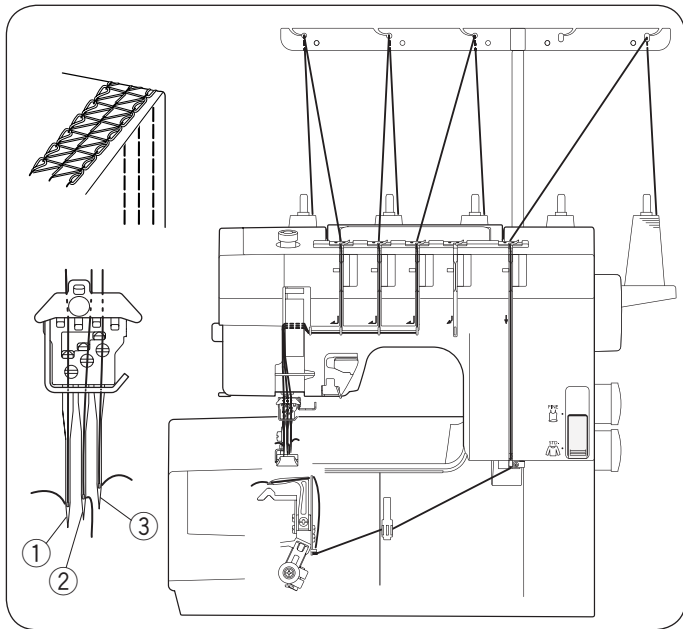

Triple Cover Stitch

The triple cover stitch is sewn with all three needles and four threads.

This stitch forms three parallel rows of the straight stitch on the right side, ideal for hemming, attaching elastics, decorative stitches, etc.

- ① Left needle
- ② Center needle
- ③ Right needle

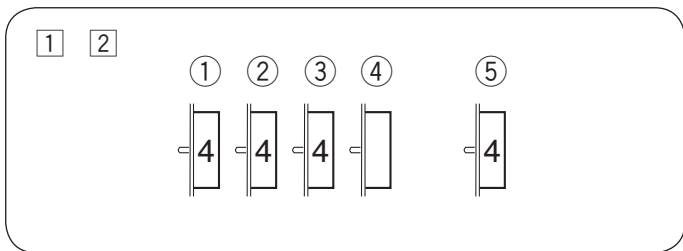

Balancing the thread tension

① Set the tension dials as follows:

- ① Left needle thread tension dial: 4
- ② Center needle thread tension dial: 4
- ③ Right needle thread tension dial: 4
- ④ Top cover stitch thread tension dial: -
- ⑤ Looper thread tension dial: 4

② Check the tension balance by test stitching on the same fabric and threads as actual garments.

Fine-tune the tension as necessary.

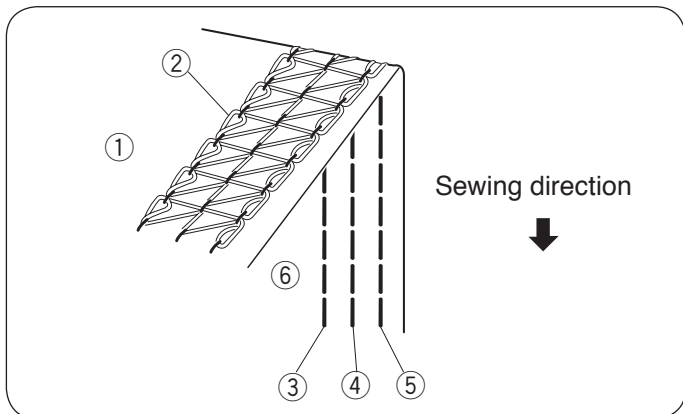

Balanced tension

The rows of stitches on the right side of the fabric are straight and even. The looper thread forms the dual rows of squares with diagonals.

- ① Wrong side of the fabric
- ② Looper thread
- ③ Left needle thread
- ④ Center needle thread
- ⑤ Right needle thread
- ⑥ Right side of the fabric

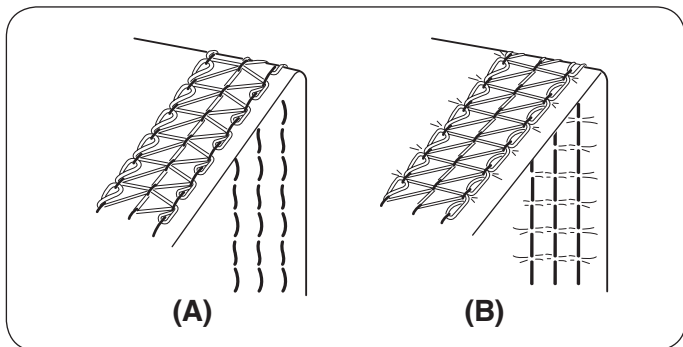

Adjusting the needle thread tension

(A) If the needle thread tension is too loose:

Tighten the needle thread tension, and/or loosen the looper thread tension to correct it.

(B) If the needle thread tension is too tight:

Loosen the needle thread tension, and/or tighten the looper thread tension to correct it.

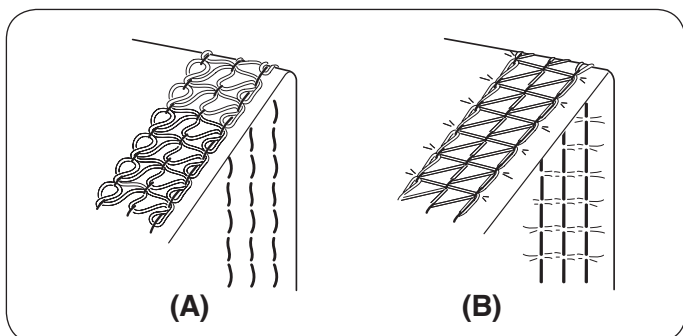

Adjusting the looper thread tension

(A) If the looper thread tension is too loose:

Tighten the looper thread tension, and/or loosen the needle thread tension to correct it.

(B) If the looper thread tension is too tight:

Loosen the looper thread tension, and/or tighten the needle thread tension to correct it.

1

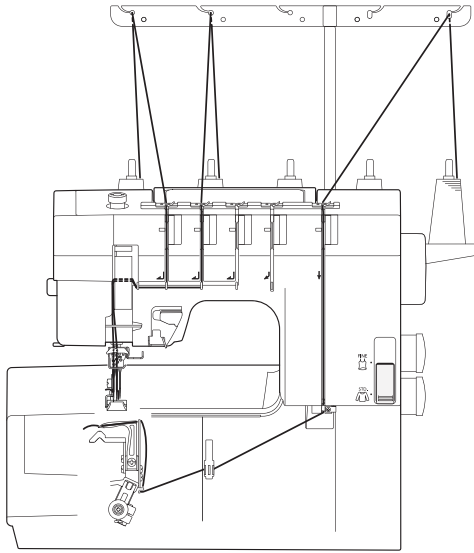
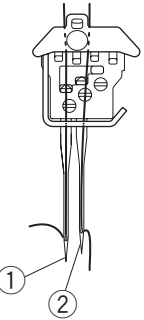
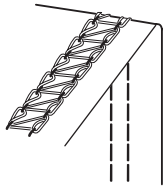

2

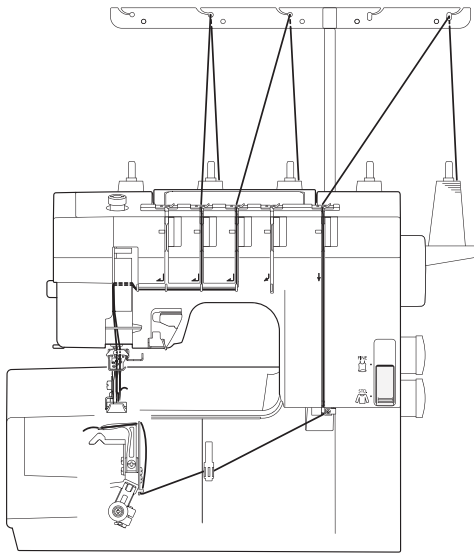
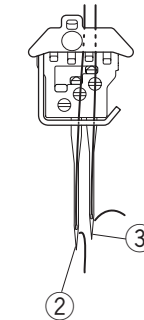
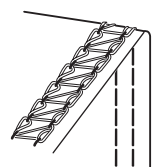

3

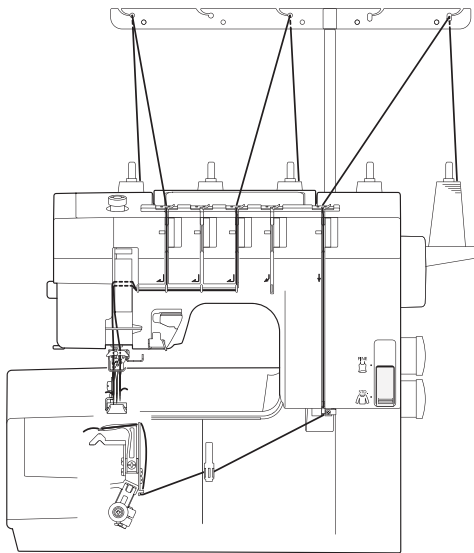
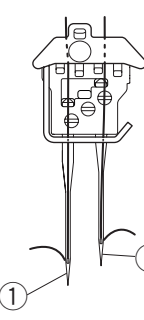
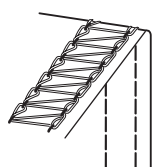

Cover Stitch

This stitch is sewn with two needles and three threads and forms two parallel rows of the straight stitch on the right side, widely used on cuffs and stretch welts of T-shirts, etc.

There are three types of cover stitch:

- Narrow 3 mm (left)
- Narrow 3 mm (right)
- Wide 6 mm

1 Narrow 3 mm (left)

Remove the right needle (refer to page 10). Thread the looper, left and center needles.

- ① Left needle
- ② Center needle

NOTE:

Tighten the needle clamp screw that is not being used to prevent losing the screw.

2 Narrow 3 mm (right)

Remove the left needle (refer to page 10). Thread the looper, right and center needles.

- ② Center needle
- ③ Right needle

NOTE:

Tighten the needle clamp screw that is not being used to prevent losing the screw.

3 Wide 6 mm

Remove the center needle (refer to page 10). Thread the looper, right and left needles.

- ① Left needle
- ③ Right needle

NOTE:

Tighten the needle clamp screw that is not being used to prevent losing the screw.

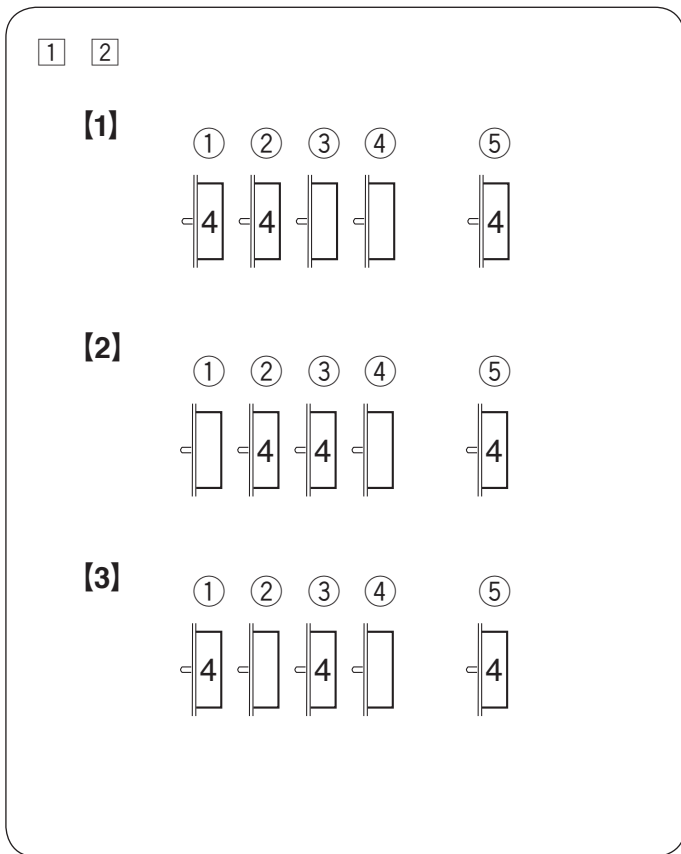

Balancing the thread tension

1 Set the tension dials as follows:

[1] For narrow 3 mm (left)

① Left needle thread tension dial:	4
② Center needle thread tension dial:	4
③ Right needle thread tension dial:	-
④ Top cover stitch thread tension dial:	-
⑤ Looper thread tension dial:	4

[2] For narrow 3 mm (right)

① Left needle thread tension dial:	-
② Center needle thread tension dial:	4
③ Right needle thread tension dial:	4
④ Top cover stitch thread tension dial:	-
⑤ Looper thread tension dial:	4

[3] For Wide 6 mm

① Left needle thread tension dial:	4
② Center needle thread tension dial:	-
③ Right needle thread tension dial:	4
④ Top cover stitch thread tension dial:	-
⑤ Looper thread tension dial:	4

2 Check the tension balance by test stitching on the same fabric and threads as actual garment.

Fine-tune the tension as necessary.

Balanced tension

The rows of stitches on the right side of the fabric are straight and even. The looper thread forms a row of squares with diagonals.

- ① Wrong side of the fabric
- ② Looper thread
- ③ Left needle thread
- ④ Right needle thread
- ⑤ Right side of the fabric

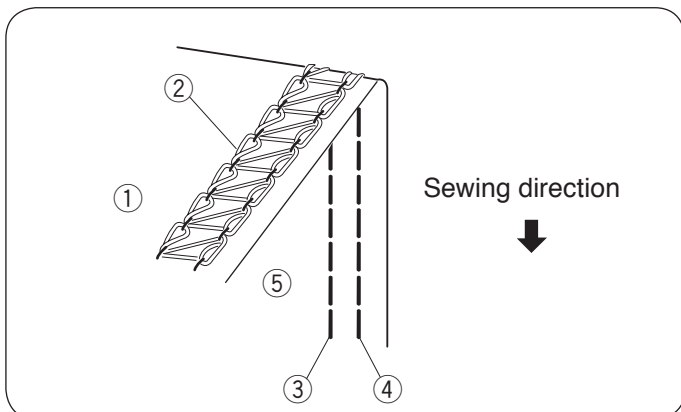

Adjusting the needle thread tension

(A) If the needle thread tension is too loose:

Tighten the needle thread tension, and/or loosen the looper thread tension to correct it.

(B) If the needle thread tension is too tight:

Loosen the needle thread tension, and/or tighten the looper thread tension to correct it.

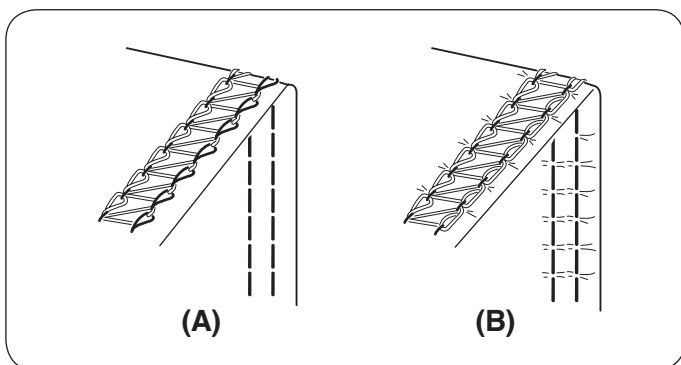

Adjusting the looper thread tension

(A) If the looper thread tension is too loose:

Tighten the looper thread tension, and/or loosen the needle thread tension to correct it.

(B) If the looper thread tension is too tight:

Loosen the looper thread tension, and/or tighten the needle thread tension to correct it.

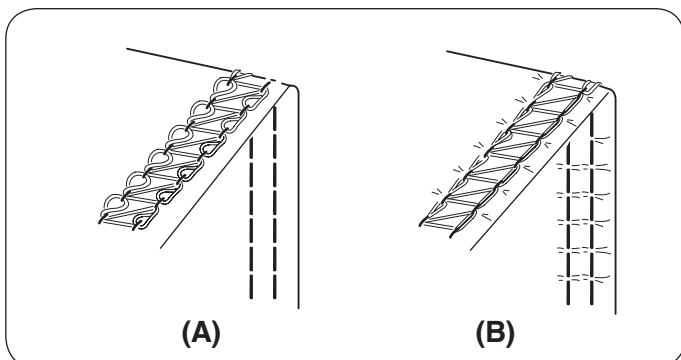

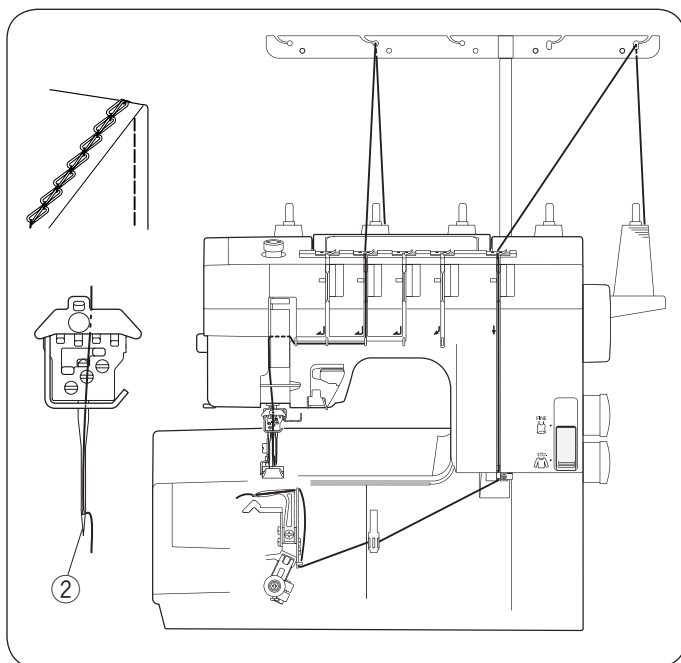

Chain Stitch

This stitch is sewn with a single needle and two threads and forms a chain of looper thread on the wrong side of the fabric.

This is a durable and flexible stitch used for seaming knit fabrics, attaching elastics, attaching bias tapes, etc.

Thread one of the three needles and looper. Remove the needles not to be used (refer to page 10).

NOTE:

Tighten the needle clamp screws that are not being used to prevent losing the screws.

Balancing the thread tension

1 Set the tension dials as follows:

① Left needle thread tension dial:	4
② Center needle thread tension dial:	4
③ Right needle thread tension dial:	4
④ Top cover stitch thread tension dial:	-
⑤ Looper thread tension dial:	4

NOTE:

Adjust the tension dial for the needle being used.

2 Check the tension balance by test stitching on the same fabric and threads as actual garment.

Fine-tune the tension as necessary.

Balanced tension

The straight stitch on the right side of the fabric is straight and even.

The looper thread forms a chain.

- ① Wrong side of the fabric
- ② Looper thread
- ③ Needle thread
- ④ Right side of the fabric

Adjusting the needle thread tension

(A) If the needle thread tension is too loose:

Tighten the needle thread tension, and/or loosen the looper thread tension to correct it.

(B) If the needle thread tension is too tight:

Loosen the needle thread tension, and/or tighten the looper thread tension to correct it.

Adjusting the looper thread tension

(A) If the looper thread tension is too loose:

Tighten the looper thread tension, and/or loosen the needle thread tension to correct it.

(B) If the looper thread tension is too tight:

Loosen the looper thread tension, and/or tighten the needle thread tension to correct it.

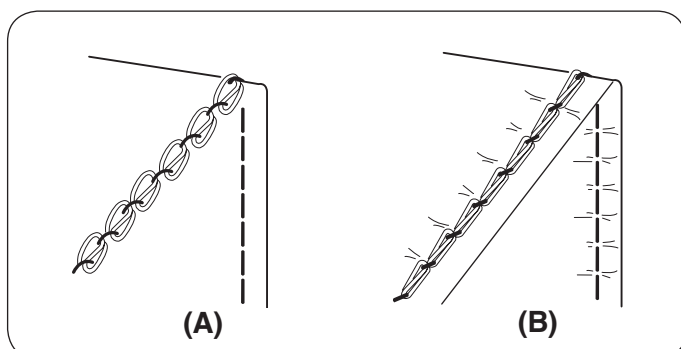
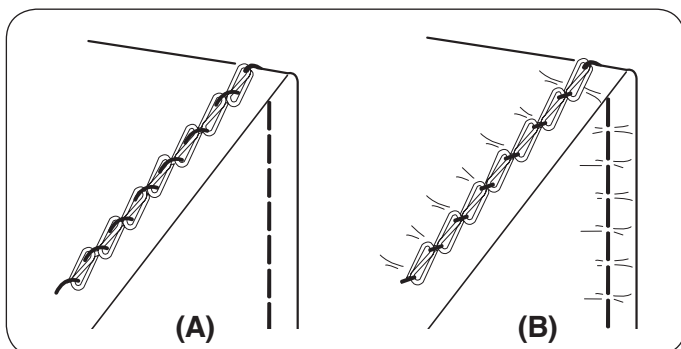
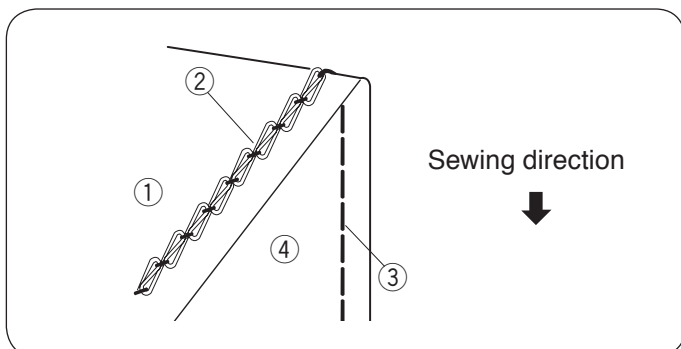
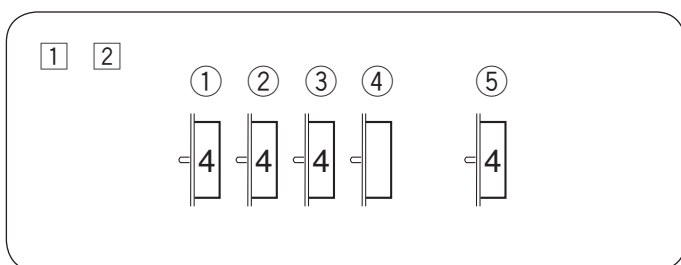

Stitch and Thread Tension Chart

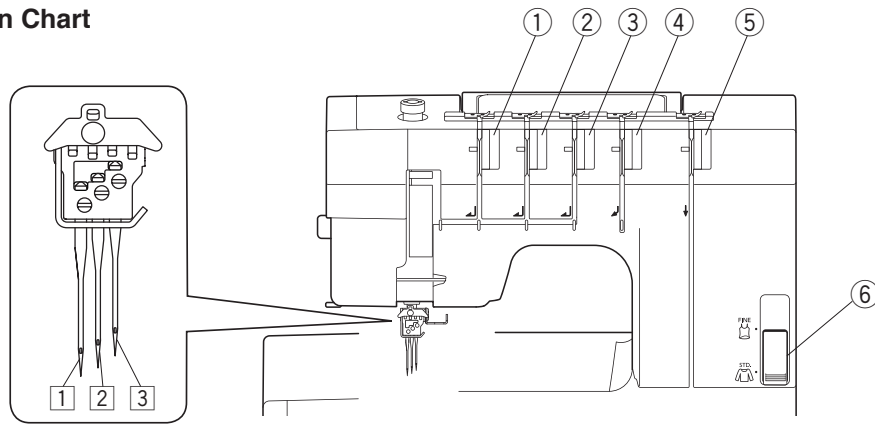

Standard to Heavy fabrics

When sewing standard to heavy fabrics, turn the fine mode switching lever to STD. and adjust the thread tension dials referring to the chart below. Use Schmetz EL X 705 80/12 or 90/14 needles and #90 to #60 spun threads. For top cover stitch, #30 and #8 spun thread can also be used (refer to pages 9, 12 - 18, 22 - 31).

Type of stitch		Needle number	Thread number	Thread tension dials					Fine mode switching lever ^⑥	Stitch
				① Left needle thread	② Center needle thread	③ Right needle thread	④ Top cover thread	⑤ Looper thread		
Top cover stitch	Triple top cover stitch	1 2 3	5	3-6	3-6	3-6	1-5	2-5	STD.	
	Narrow 3 mm (Right)	2 3	4	—	3-6	3-6	2-6	2-5	STD.	
	Wide 6 mm	1 3	4	3-6	—	3-6	1-5	2-5	STD.	
Cover stitch	Triple cover stitch	1 2 3	4	3-6	3-6	3-6	—	2-5	STD.	
	Narrow 3 mm (Left)	1 2	3	3-6	3-6	—	—	2-5	STD.	
	Narrow 3 mm (Right)	2 3		—	3-6	3-6	—	2-5	STD.	
	Wide 6 mm	1 3		3-6	—	3-6	—	2-5	STD.	
Chain stitch	Left needle	1	2	3-6	—	—	—	2-5	STD.	
	Center needle	2		—	3-6	—	—	2-5	STD.	
	Right needle	3		—	—	3-6	—	2-5	STD.	

* When having trouble in feeding fabrics, turn the dial to larger number to have longer stitch length and support sewing by hands.



* When sewing heavy fabrics, it will cause skipped stitches, damage of needles or breakage of threads.

* Numbers in this chart are approximate figures. Please adjust dials for your preference.

Stitch and Thread Tension Chart

Fine fabrics

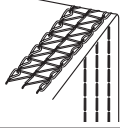
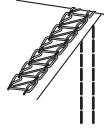
When sewing fine fabrics, turn the fine mode switching lever to FINE and adjust the thread tension dials referring to the chart below. Use Schmetz EL X 705 80/12 or 90/14 needles and #90 to #60 spun thread.

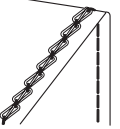
Type of stitch		Needle number	Thread number	Thread tension dials					⑥ Fine mode switching lever	Stitch
				① Left needle thread	② Center needle thread	③ Right needle thread	④ Top cover thread	⑤ Looper thread		
Cover stitch	Triple cover stitch	1 2 3	4	2-5	2-5	2-5	—	1-4	FINE	
	Narrow 3 mm (Left)	1 2	3	2-5	2-5	—	—	1-4	FINE	
	Narrow 3 mm (Right)	2 3		—	2-5	2-5	—	1-4	FINE	
	Wide 6 mm	1 3		2-5	—	2-5	—	1-4	FINE	
Chain stitch	Left needle	1	2	2-5	—	—	—	1-4	FINE	
	Center needle	2		—	2-5	—	—	1-4	FINE	
	Right needle	3		—	—	2-5	—	1-4	FINE	

* When having trouble in feeding fabrics, turn the dial to larger number to have longer stitch length and support sewing by hands.

* Numbers in this chart are approximate figures. Please adjust dials for your preference.

1

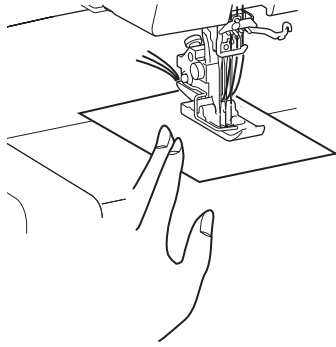
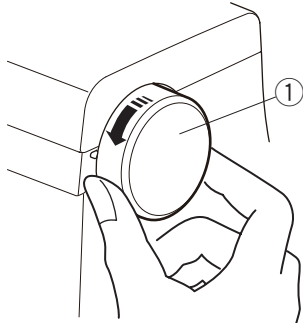

2

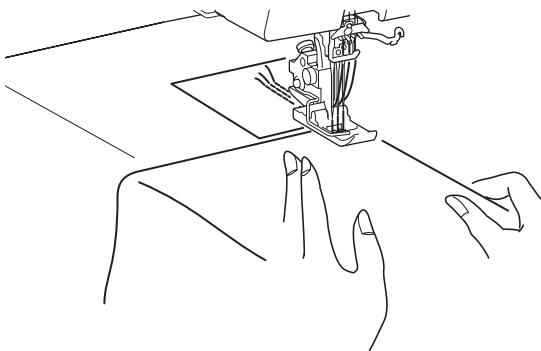
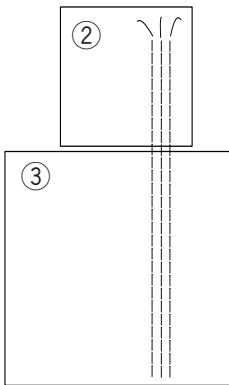

Beginning and End of the seam

At the beginning of the seam, use a piece of scrap fabric to achieve the best results.

At the end of the seam, you can choose either to end sewing with the thread chain or without thread chain (A thread chain is a chain of threads knit without fabric).

Beginning of the seam

- 1 Turn the handwheel toward you to bring the needle to its highest position.

Raise the presser foot lifter and insert a piece of scrap fabric under the foot.

Lower the presser foot lifter.

Depress the foot control to start sewing slowly.

- 1 Handwheel

- 2 Stop sewing at the end of the scrap fabric.

Insert the work fabric after the scrap as shown, then start sewing on the work fabric.

- 2 Scrap fabric
- 3 Work fabric

End of the seam with thread chain

NOTE:

Turn the stitch length dial to 4 when sewing the triple cover stitch.

- 1 Stop sewing at the end of the work fabric.
Turn the stitch length dial to 4 and start the machine to slowly produce approximately 5" (12 cm) of thread chain while gently pulling the thread chain to the back.

① Stitch length dial

- 2 Cut the thread chain with the thread cutter as shown, leaving a thread chain approximately 2" (5 cm) long on the end of the fabric.

② Thread cutter

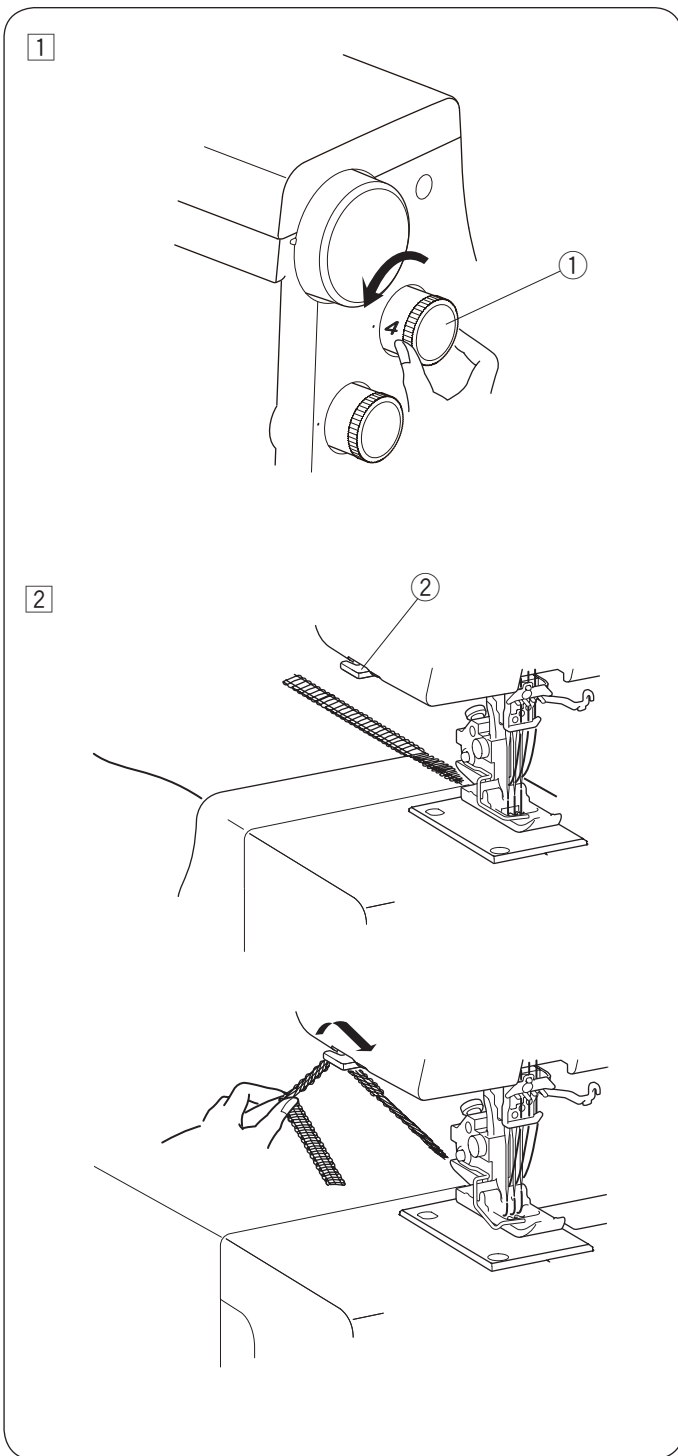

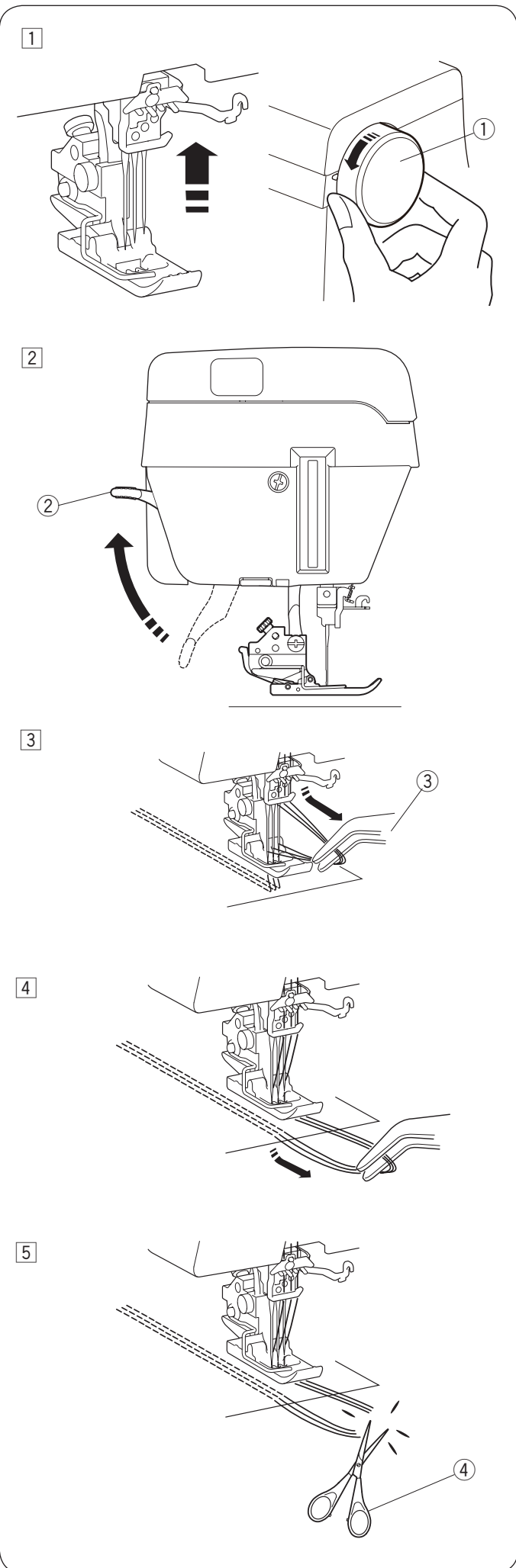

End of the seam without thread chain

- 1 Stop sewing at the end of the work fabric.
Turn the handwheel toward you to bring the needle to its highest position.

① Handwheel

- 2 Raise the presser foot with the presser foot lifter.

② Presser foot lifter

- 3 Pull the needle threads before the needle eyes using the tweezers.

This prevents the threads get tangled when removing the fabric.

③ Tweezers

- 4 Pull the needle threads about 4" (10 cm) forward from the bottom of the foot using the tweezers.

- 5 Cut the loop of threads with scissors.

④ Scissors

6

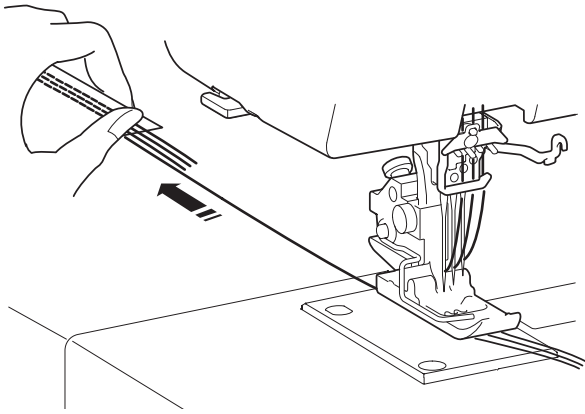

5

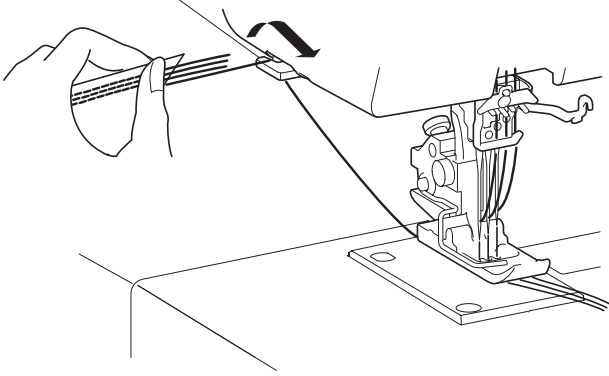

6 Hold the seam tightly and pull the fabric to the rear, then cut the looper thread with the thread cutter.

5 Thread cutter

NOTE:

Pull the fabric to the rear to prevent threads get tangled in needle holes.

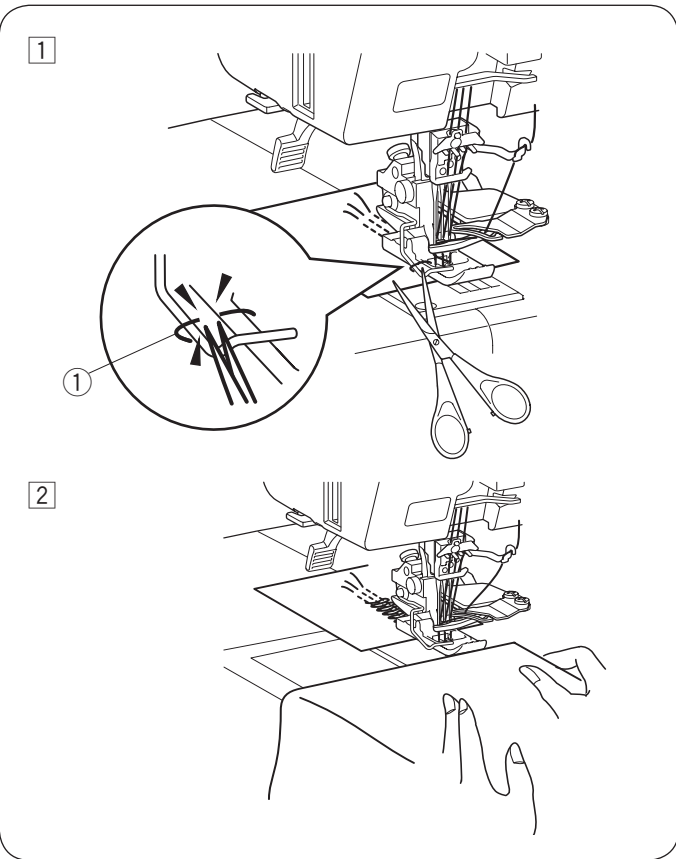

Beginning of the seam for top cover stitch

- 1 After threading the top cover stitch thread, turn the handwheel toward you for several times and sew 3 to 5 top cover stitches on a piece of scrap fabric. Cut the loose top cover thread.
 - ① Loose top cover stitch thread

- 2 Depress the foot control to start sewing slowly. Stop sewing at the end of the scrap fabric. Insert the work fabric after the scrap as shown, then start sewing on the work fabric.

NOTE:

Always keep low to middle speed while sewing the top cover stitches.

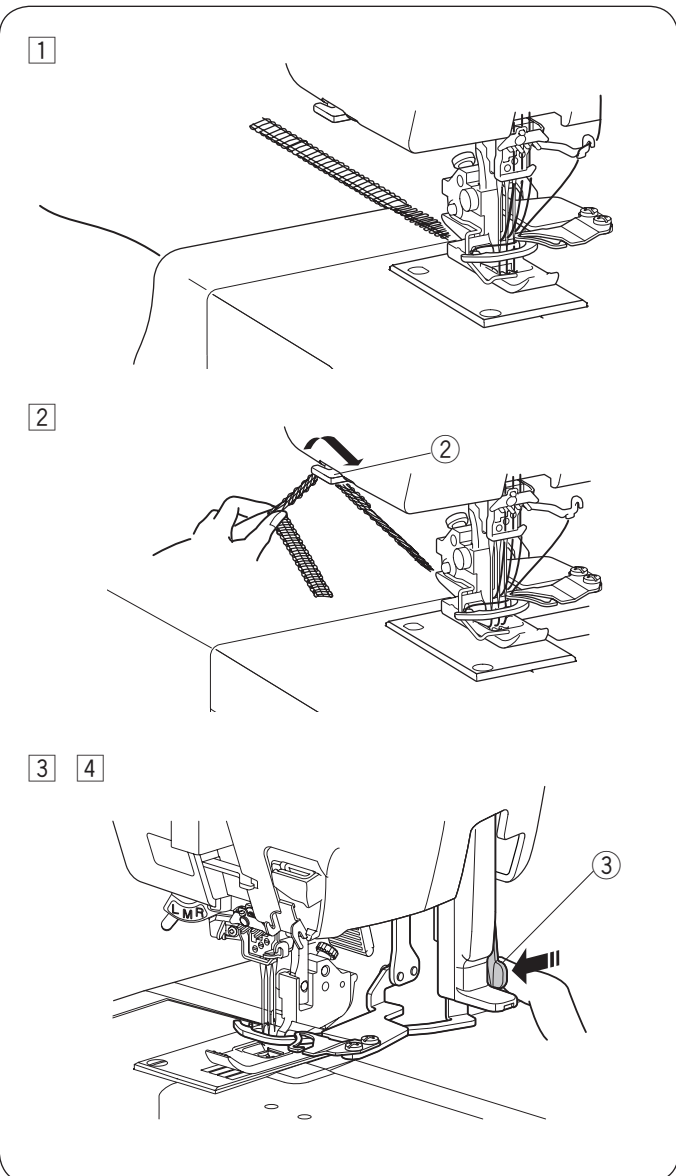

End of the seam for top cover stitch

- 1 At the end of the seam, slowly produce approximately 5" (12 cm) of thread chain while gently pulling the thread chain to the back (A thread chain is a chain of threads knit without fabric).

- 2 Cut the thread chain with thread cutter as shown, leaving a thread chain approximately 2" (5 cm) long on the end of the fabric.
 - ② Thread cutter

- 3 Raise the needle to the highest position after sewing. Raise the presser foot lifter. Remove the top cover stitch thread from the top cover stitch spreader.

- 4 Pull the top cover stitch release lever toward you to store the top cover stitch spreader to the machine.
 - ③ Top cover stitch release lever

NOTE:

If the threads are cut in the middle of sewing, remove the top cover stitch thread from the top cover stitch spreader and start the threading from the beginning. Refer to pages 12 - 18 and 22 - 25 for threading.

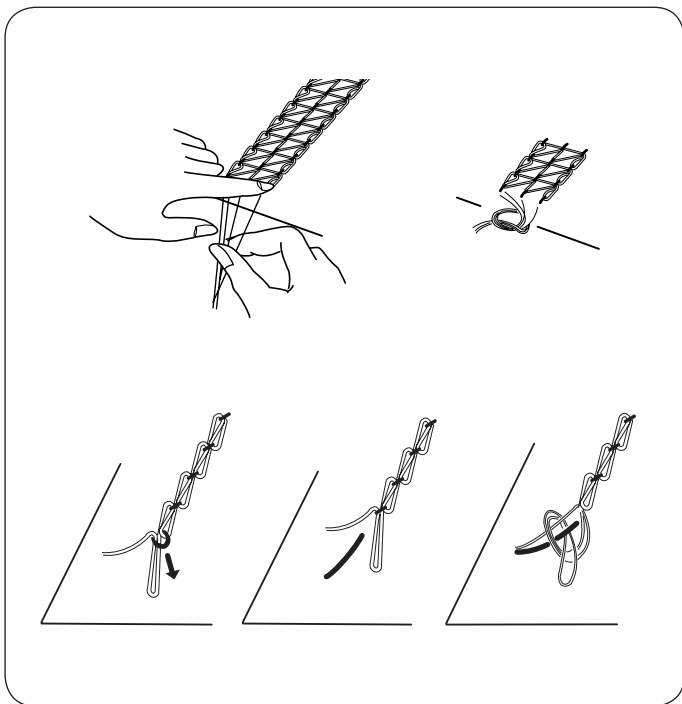

Knotted the threads

For cover stitches and top cover stitches

If the threads are shown on the right side of the fabric, draw them to the wrong side of the fabric by using a pair of tweezers and knot them together.

For chain stitches

Draw the threads to the wrong side of the fabric by using a pair of tweezers and knot them together.

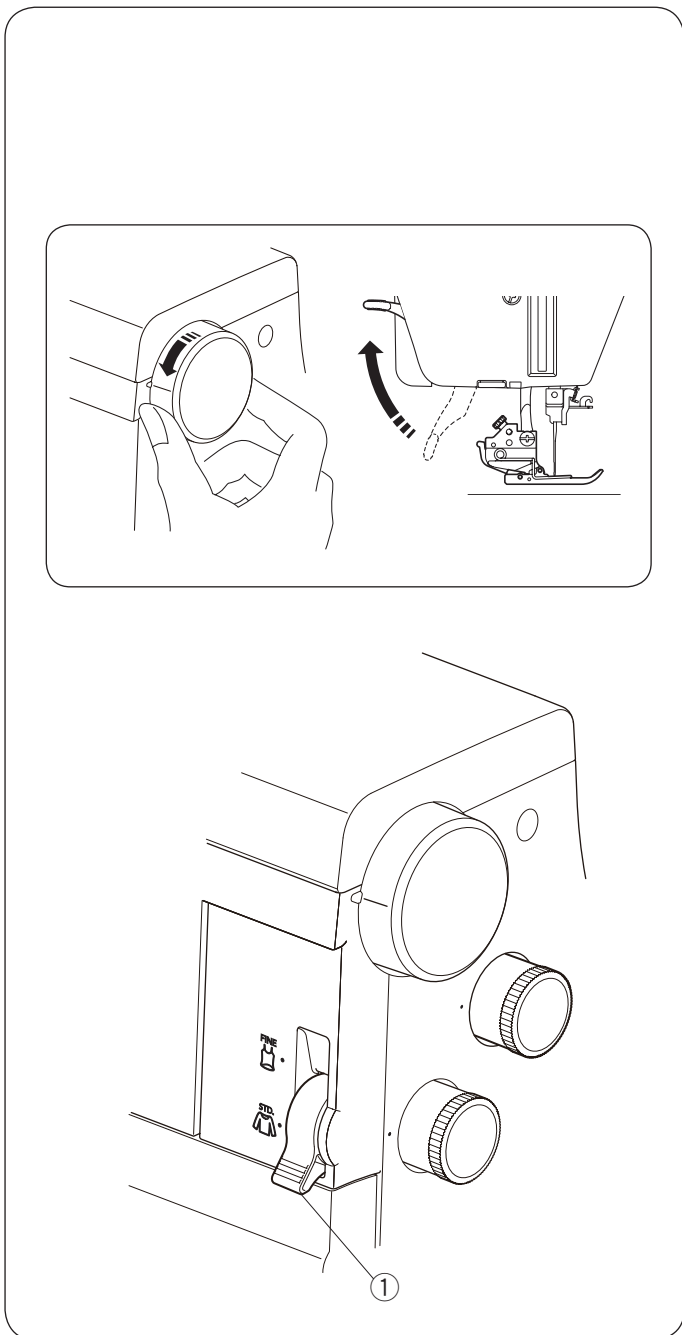

Curling problem

NOTE:

- Raise the needle to the highest position by turning the handwheel toward you to match the mark on the machine with the setting mark on the handwheel.
- Raise the presser foot lifter.

When the curling problem occurs, adjust the following steps;

- Turn the fine mode switching lever to "FINE" (refer to page 9).
 - ① Fine mode switching lever
- Turn the looper thread tension dial to a lower numbers (refer to pages 32 - 33).
- Use thinner thread (refer to page 26).

Skipped stitch

When the skipped stitch occurs, adjust the following steps;

- Turn the fine mode switching lever to "STD" or "FINE" (refer to page 9).
- Turn the stitch length dial to adjust the stitch length to a higher length (refer to page 8).
- Adjust the thread tension dials (refer to pages 26 - 33).

NOTE:

Check every threads are correctly threaded (refer to pages 13 - 25).

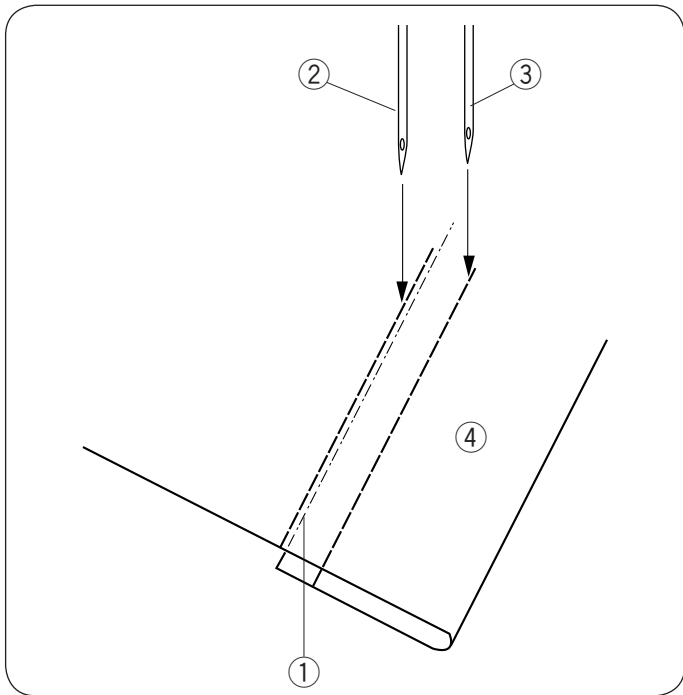

Hemming with the Cover Stitch

Fold up the edge of the fabric to the wrong side and press.

Draw a line with a tailor's chalk on the right side of the fabric to mark the fabric edge.

Place the fabric so the left needle drops just to the left side of the marked line.

Lower the presser foot lifter.

Sew carefully along the marked line.

After finishing sewing, raise the presser foot lifter and remove the fabric to the rear.

Draw the needle threads to the wrong side of the fabric and knot them together.

- ① Marked line
- ② Left needle
- ③ Right needle
- ④ Right side of the fabric

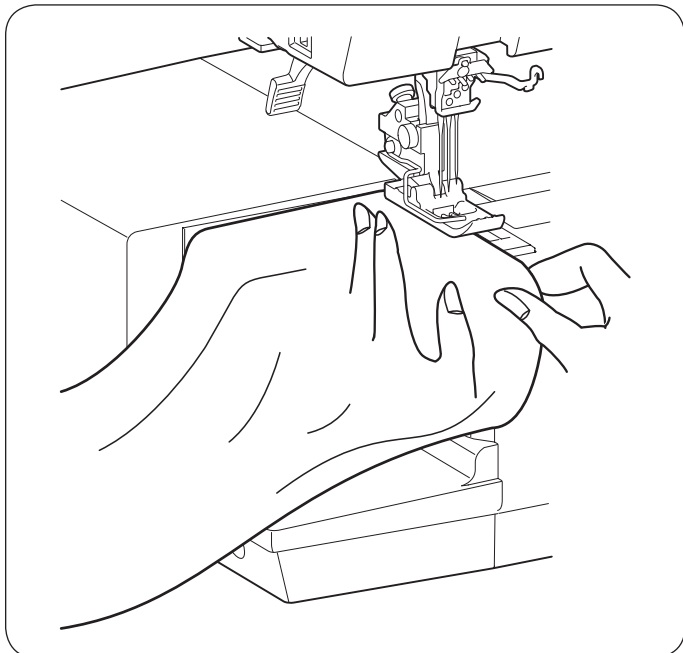

Free Arm Hemming

The extension table can be detached for free arm hemming on the tubular parts of the garments, such as sleeves, cuffs, etc.

Remove the extension table (refer to page 5).

Stitch the hem in the same way as hemming with cover stitch (refer to "Hemming with the cover stitch" on page 40).

Continue to sew over the stitches 2" (4 to 5 cm) beyond the beginning of the seam and stop the machine.

Cut the threads at the beginning and at the end.

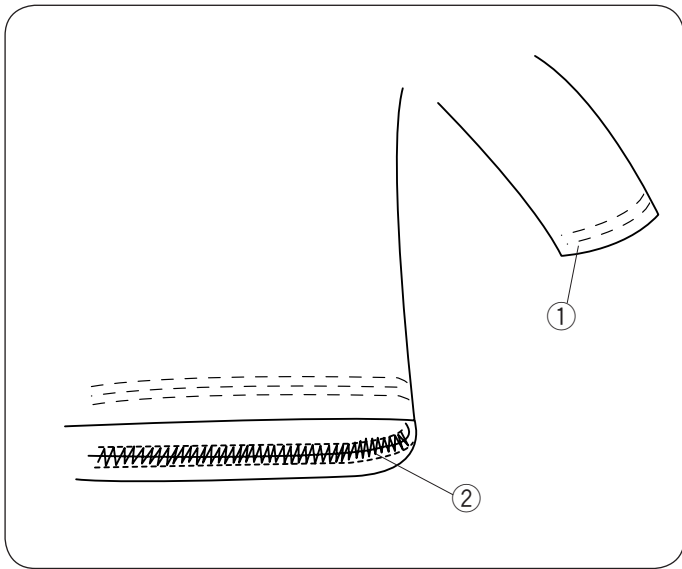

Triple Cover Stitch Applications
Hemming on sleeves and waistlines

- ① Sleeve
- ② Waistline

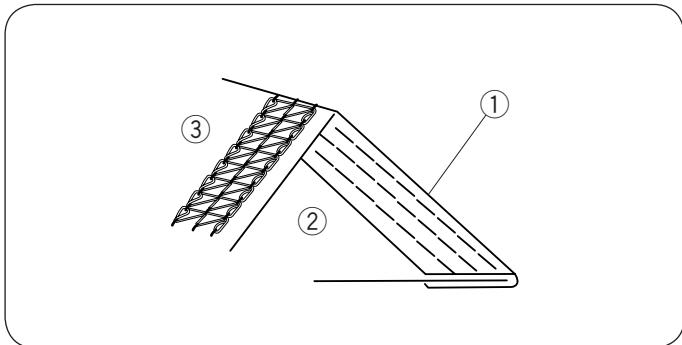

Attaching laces and tapes

- ① Tape or lace
- ② Right side of the fabric
- ③ Wrong side of the fabric

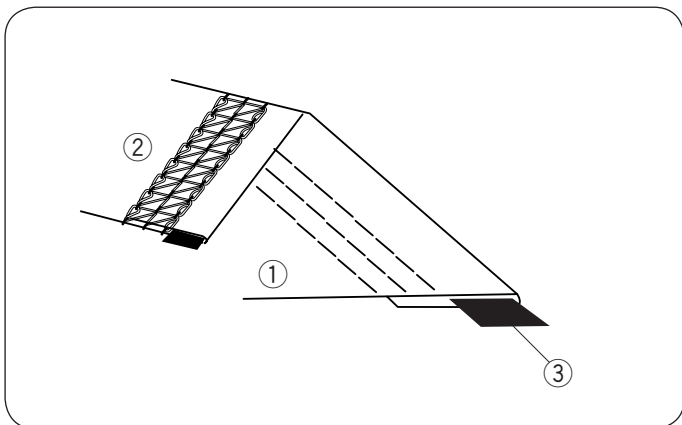

Attaching elastics

- ① Right side of the fabric
- ② Wrong side of the fabric
- ③ Elastic

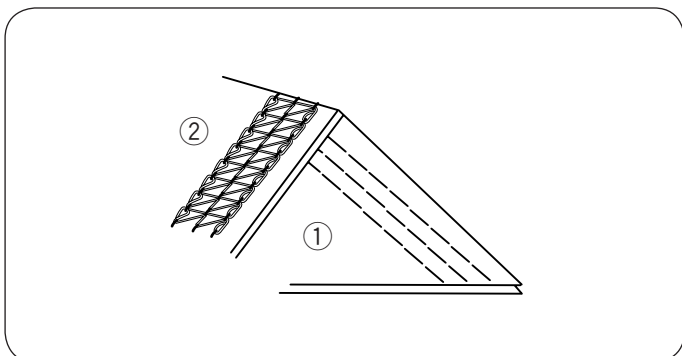

Decorative stitch

- ① Right side of the fabric
- ② Wrong side of the fabric

CARE OF YOUR MACHINE

Cleaning the Feed Dogs and Looper Area

⚠ WARNING:

Turn off the power switch and unplug the machine before cleaning.
Do not dismantle the machine in any way other than what is explained in this section.

- 1 Remove the presser foot and needles (refer to pages 7 and 10).

- 2 Open the looper cover.
Remove the setscrew.

Raise the presser foot lifter to the extra lifted position and remove the needle plate (refer to page 7).

- 1 Setscrew
- 2 Needle plate

- 3 Clean the feed dogs with the lint brush.
3 Lint brush

- 4 Pull the looper release knob.
Clean the looper and surrounding area with the lint brush.

- 4 Looper release knob

- 5 Push the looper back to the original position.
Raise the presser foot lifter to the extra lifted position and replace the needle plate, needles and presser foot.

Close the looper cover.

- 5 Looper cover

NOTE:

Machines with high use frequency tend to have lint or dust around areas beyond the reach and cause malfunctions.
Periodic maintenance is recommended for those machines. Contact the store you purchased the machine.

Troubleshooting

Problem	Cause	Reference
Needle thread breaks.	<ol style="list-style-type: none"> 1. The machine is not threaded correctly. 2. The thread tension is too tight. 3. The needle is bent or blunt. 4. The needle is incorrectly inserted. 5. A wrong needle is used. 6. Fabric is too heavy. 	<p>Refer to pages 12 - 25</p> <p>Refer to pages 26 - 33</p> <p>Refer to page 10</p> <p>Refer to page 10</p> <p>Refer to page 10</p> <p>Refer to pages 32 - 33</p>
Needle bends or breaks.	<ol style="list-style-type: none"> 1. The needle is bent or blunt. 2. The needle is incorrectly inserted. 3. The needle clamp screw is loose. 4. The fabric is forcedly pulled. 5. The number of the needle is wrong. 	<p>Refer to page 10</p> <p>Refer to page 10</p> <p>Refer to page 10</p> <p>Do not pull the fabric.</p> <p>Refer to page 26</p>
Skipped stitches	<ol style="list-style-type: none"> 1. The needle is incorrectly inserted. 2. The needle is bent or blunt. 3. The tension is not adjusted correctly. 4. The machine is not threaded correctly. 5. Fabric is too heavy. 6. The number of the needle is wrong. 	<p>Refer to page 10</p> <p>Refer to page 10</p> <p>Refer to pages 26 - 33</p> <p>Refer to pages 12 - 25</p> <p>Refer to pages 32 - 33</p> <p>Refer to page 26</p>
Seam puckering	<ol style="list-style-type: none"> 1. The needle and/or looper thread tensions are not adjusted correctly. 2. Fine mode switching lever is not positioned correctly. 3. Easily stretched threads such as wool are use. 	<p>Refer to pages 26 - 33</p> <p>Refer to page 9</p> <p>Use spun.</p>
The cloth is not feeding smoothly.	<ol style="list-style-type: none"> 1. The presser foot is raised. 2. Presser foot pressure is too weak. 3. The feed dog is packed with lint. 	<p>Refer to page 6</p> <p>Refer to page 8</p> <p>Refer to page 42</p>
Machine does not operate.	<ol style="list-style-type: none"> 1. The machine is not connected correctly to the power supply. 2. The foot control is not plugged in firmly. 3. The power switch is turned off. 	<p>Refer to page 4</p> <p>Refer to page 4</p> <p>Turn on the power switch.</p>

EC DECLARATION OF CONFORMITY

Manufacturer: Janome Sewing Machine Co., Ltd.

Address: 1463 Hazama-machi, Hachioji-shi, Tokyo 193-0941, Japan

This machine complies with the following regulations:

EN 60335-1:2012;A11;A13;A1;A14;A2

EN 60335-2-28:2003;A1;A11

EN 62233:2008

EN 55014-1:2017;A11

EN 55014-2:2015

EN IEC 61000-3-2:2019

EN 61000-3-3:2013;A1

